

PARTS LIST: TU33208;TU33209

1	Front Bumper	6	10-1.50mm x 35mm Hex Bolts
1	Long Center Fill Panel	12	10mm x 34mm x 3mm Large Flat Washers
2	Small Inner Fill Panels	6	10mm Lock Washers
2	Small Outer Fill Panels	6	10-1.5mm Hex Nuts
1	Driver/left Frame Bracket	4	8-1.25mm x 25mm Button Head Bolts
1	Passenger/right Frame Bracket	1	8-1.25mm x 50mm Hex Bolts
1	Active Air Dam Relocation Bracket	2	8-1.25mm x 25mm Hex Bolts
1	Active Air Dam Top Support Bracket	2	8-1.25mm x 16mm Hex Bolts
2	Active Air Dam Relocation Bracket Spacers	16	8mm x 24mm x 2mm Flat Washers
1	Driver/left side LED "L" Bracket	8	8mm Lock Washers
1	Passenger/right side LED "L" Bracket	1	8-1.25mm Nylon Lock Nut
1	Driver/left side Top Light Bracket	6	8-1.25mm Hex Nuts
1	Passenger/right side Top Light Bracket	14	6-1.0mm x 20mm Combo Bolts
2	Edge Trim (1M)	3	6-1.0mm x 20mm Combo Bolts (large washer)
1	License Plate Bracket	3	6-1.0mm x 20mm Button Head Bolts
2	Plastic License Plugs	1	6-1.0mm x 50mm Hex Bolt
4	12-1.75mm x 40mm Hex Bolts	8	6mm x 18mm x 1.6mm Flat Washers
8	12mm x 24mm x 2.5mm Flat Washers	4	6mm Nylon Lock Nuts
4	12mm Lock Washers	14	6mm Flange Hex Nuts
4	12mm Hex Nuts	10	Nylon Wire Ties
		1	4mm Hex Wrench

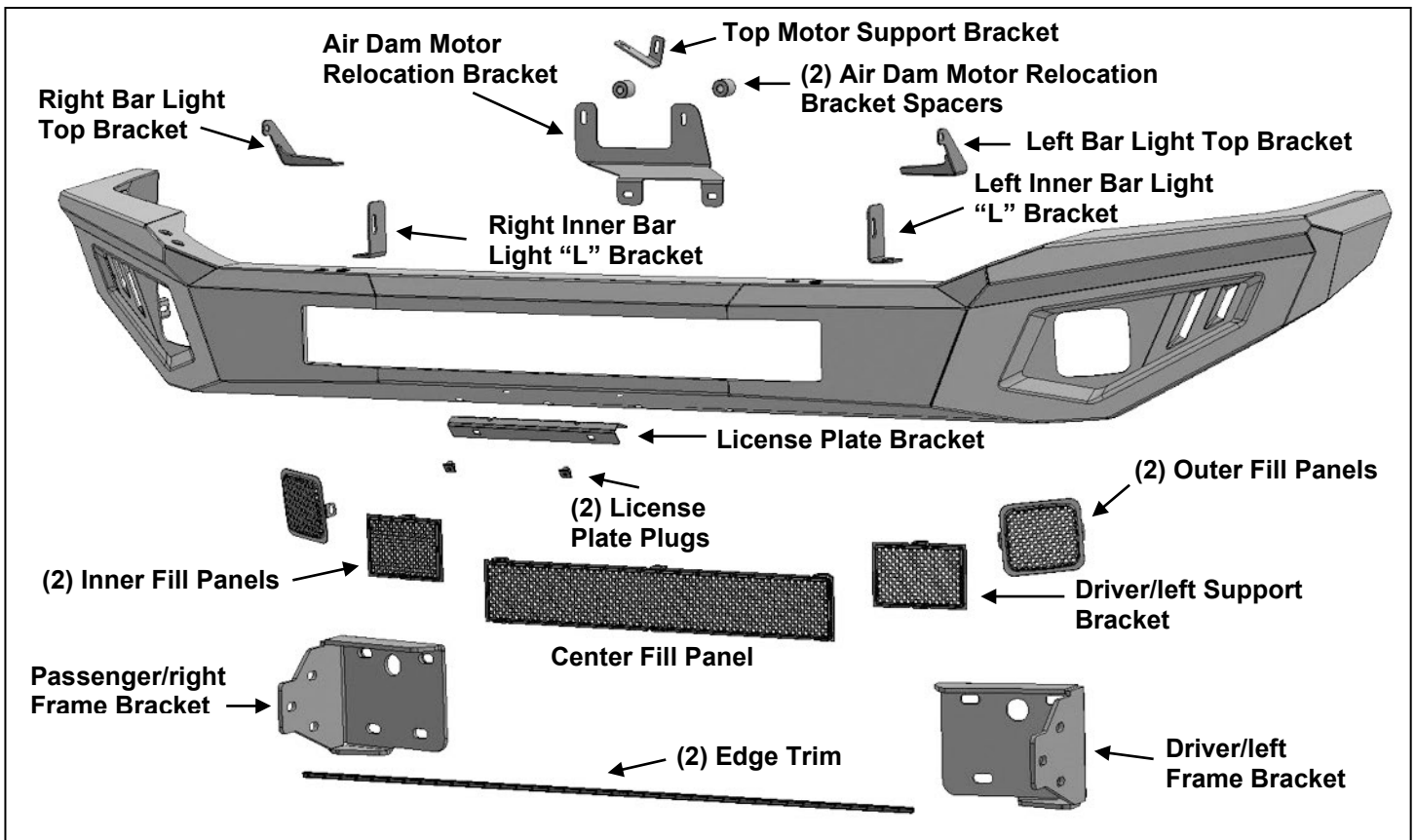

PROCEDURE:

REMOVE CONTENTS FROM BOX. VERIFY ALL PARTS ARE PRESENT. READ INSTRUCTIONS CAREFULLY BEFORE STARTING INSTALLATION. BUMPER IS HEAVY, ASSISTANCE IS HIGHLY RECOMMENDED TO AVOID POSSIBLE INJURY OR DAMAGE TO THE VEHICLE. CUTTING IS REQUIRED.

1. Move to the driver/left wheel opening. Remove the hardware attaching the inner fender liner to the back and bottom of the outer end of the front bumper and fender, **(Figure 1)**. Also pull the end of the fender flare (if equipped) to release the flare from the bumper cover, **(Figure 2)**. **NOTE:** Do not remove the fender flare, only release the forward end of the flare from the bumper cover. Repeat this **Step** to remove the hardware and release the flare from the passenger/right side of the vehicle.
2. Remove the license plate. Remove the hardware attaching the bottom of the bumper cover to the vehicle, **(Figure 3)**. Remove the lower panel from the bottom of the bumper cover, **(Figure 4)**.
3. Open the front hood and unplug all harnesses leading to the driver/left and passenger/right side of the grille and front bumper, **(Figure 5)**.
4. Remove the hardware attaching the top of the grille to the radiator core support, **(Figure 6)**. With assistance, carefully pull the grille and bumper cover off as an assembly, **(Figure 7)**. To avoid damage to the finish, place assembly on a soft surface.
5. Unplug the wiring harness leading to the active air dam motor, **(Figure 8)**. Remove the aluminum impact bumper, **(Figures 9 & 10)**.
6. Remove the active air dam from the air dam motor, **(Figure 11)**. Next, remove the motor assembly from the back of the impact bumper, **(Figure 12)**.
7. Remove the plastic cover from the motor assembly. Cut the air dam bracket off of the mounting drum, **(Figure 12)**.

Optional-requires partial motor disassembly to cut air dam bracket:

- a. Remove the long cross pivot bolt, **(Figure 13)**.
 - b. Remove the outer caps, inner drive cups and spring, **(Figures 14 & 15)**.
 - c. Slide air dam mount out of pivot bracket, **(Figures 16 & 17)**.
 - d. Cut bracket off of air dam mount, **(Figure 18)**.
 - e. Reassemble motor assembly.
8. Move to the grille opening. Locate the water hose running across the grille opening, **(Figure 19)**. Release hose from center bracket. Remove the hex nuts attaching the hose mounting brackets at the ends of the hose and pull the brackets off of the threaded studs, **(Figures 20 & 21)**. **IMPORTANT:** Do not disconnect the hose, only move the brackets on the hose off of the mounting studs.
 9. Remove the hex bolt attaching the center vertical core support bracket to the front of the lower crossmember, **(Figure 22)**. Pull the bracket outward and slide the hose under and behind the support bracket, **(Figure 23)**. Reattach the hose brackets and secure the hose to the back of the support.
 10. Select the air dam motor assembly and Relocation Bracket. Attach the bottom of the motor assembly to the back of the Relocation Bracket and Bracket Spacers with (1) 6mm x 50mm Hex Bolt, (2) 6mm Flat Washers, (1) 6mm Nylon Lock Nut, (1) 8mm x 50mm Hex Bolt, (2) 8mm Flat Washers and (1) 8mm Nylon Lock Nut, **(Figure 24)**. Insert the (2) Bracket Spacers between the back of the Relocation Bracket and the tabs on the motor assembly.
 11. Slide the bottom of the Relocation Bracket between the core support bracket and the crossmember. Attach the bottom of the Relocation Bracket to the front of the lower crossmember and support bracket with the included (2) 6mm Button Head Combo Bolts with oversized flat washers, **(Figures 24 & 25)**.
 12. Remove the hex bolt from the passenger/right side of the hood release, **(Figure 26)**. Select the Motor Upper Support Bracket. Attach the Bracket to the hood release and core support with (1) 6mm x 20mm Button Head Combo Bolt with oversized flat washer, **(Figure 27)**. Attach the Support Bracket to the top of the motor assembly with (1) 6mm x 20mm Button Head Bolt, (2) 6mm Flat Washers and (1) 6mm Nylon Lock Nut, **(Figures 27 & 28)**.
 13. Plug wiring harness into air dam motor. Tighten all Relocation Bracket and hose mounting hardware.
 14. Select driver/left Frame Bracket, **(Figure 29)**. Reuse the (2) factory hex bolts to attach the bottom of the Bracket to the end of the frame. Leave hardware loose. Use the included (2) 12mm x 40mm Hex Bolts,

- (4) 12mm Flat Washers, (2) 12mm Lock Washers and (2) 12mm Hex Nuts to attach the top of the Frame Bracket to the end of the frame, **(Figures 29 & 30)**. Snug but do not fully tighten hardware at this time. Repeat this **Step** to attach the passenger/right side Frame Bracket.
15. Move to the factory grille and bumper assembly. Disassemble the grille/bumper. Remove the plastic end panels and fill panels from the bumper, **(Figure 31)**. Remove the plastic fascia panel surrounding the fog lights attached to the bottom of the grille.
 16. Select the center grille body panel, **(Figure 32)**. Use removable tape (masking tape) to create a straight line following the opening in the center of the panel below the fog lights and above the front parking sensors if equipped, **(Figure 33)**. Use a sharp knife or hacksaw blade to cut a straight line across the bottom of the panel, **(Figure 34)**. **NOTE:** On models equipped with front parking sensors, a relocation kit is required to install the sensors on the Bumper (not included, available separately). Temporarily reinstall the center panel. Mark the bottom of the inner grille support to match the outer body panel and cut off the bottom of the inner grille.
 17. Next, select the passenger/right plastic bumper end cover, **(Figure 35)**. Place a mark 8-1/4" (210mm) straight down from the crease in the cover to the wheel opening. Place a mark 12-1/4" (310mm) straight down from the peak on the cover, **(Figure 36)**. Place a mark 8-3/8" (215mm) straight down from the headlight opening on the cover, **(Figure 37)**. Make a final mark 5/8" (15mm) above the crease on the inner side of the cover, **(Figure 38)**. Use removable tape (masking tape) to create a straight line following the marks on the cover, **(Figure 39)**. Use a sharp knife or hacksaw blade to cut a straight line across the bottom of the bumper end. Temporarily reinstall the cover. Repeat this Step to cut the driver/left side bumper end cover.
 18. Select the passenger/right bumper fill panel, located between the center panel and outer end cover, **(Figure 40)**. Line up the fill panel with the previously cut center and outer covers. Use masking tape to make a diagonal line from the corner of the center panel to the bottom inner corner on the outer cover. Cut the fill panel along this line to match the other panels. Place the fill panel in position on the grille and mark the plastic grille to cut to match the cover, **(Figures 41 & 42)**. Repeat this **Step** to cut the driver/left bumper fill panel.
 19. Carefully unwrap the Bumper assembly. With assistance, position the Bumper Assembly up to the inside of the Frame Brackets. Temporarily support the weight of the Bumper. **WARNING:** To avoid possible injury or damage to the vehicle, do not proceed until the Bumper is fully and safely supported.
 20. Attach the Bumper to the inside of the Frame Brackets with the included (6) 10mm Hex Bolts, (12) 10mm Flat Washers, (6) 10mm Lock Washers and (6) 10mm Hex Nuts, **(Figures 48 & 49)**. Do not fully tighten hardware at this time.
 21. Align and level the front Bumper. Check the fit of all cut panels and trim panels to match the Bumper. **NOTE:** It may be necessary to remove and install the Bumper a few times for best results. Once all cut panels have been matched up, temporarily remove the Bumper.
 22. Fully tighten all grille and bumper hardware and fully reattach all bumper panels. Clean up cut sections and push Edge Trim onto cut bumper covers and fill panels, **(Figures 43 & 44)**. Plug in all wiring harnesses leading to the grille and bumper as described in **Step 5**.
 23. Determine if accessory lights, (not included), or Screen Fill Panels will be installed at this time. **IMPORTANT:** It may be easier to install Center Fill Panels and/or lights before installing Bumper.

Screen Fill Panel Installation (do not install fill panels if installing lights).

- a. Select desired Screen Fill Panels. **NOTE:** Outer Panels are square with rounded corners, Inner panels are rectangular with sharp corners, **(Figure 45)**.
- b. Attach Screen Fill Panels as needed with the included 6mm Button Head Combo Bolts and 6mm Flange Nuts, **(Figure 45)**. Fully tighten Fill Panel hardware at this time. Repeat to install all Panels as desired.

Inner center LED bar style light installation (light not included).

- a. Select the driver/left "L" Light Bar Bracket, **(Figure 46)**. **NOTE:** "L" Brackets are offset to adjust for different widths of LED Bar Lights and can be installed on either side as needed.
- b. Attach the L Bracket to the slot on the back of the Bumper with (1) 8mm x 25mm Hex Bolt, (2) 8mm Flat Washers, (1) 8mm Lock Washer and (1) 8mm Hex Nut, **(Figure 46)**. Repeat this **Step** to install the remaining "L" Bracket on the other side of the Bumper. **IMPORTANT:** The Bumper features slots designed for 20" and 30" bar style lights. Attach the Brackets to the correct slots in

the Bumper. If necessary, hold the light up to the slots to help determine correct slots to use and combination of Brackets.

- c. Attach the light to the "L" Brackets with the hardware included with the light or the supplied (2) 8mm x 16mm Hex Bolts, (2) 8mm Lock Washers and (2) 8mm Flat Washers or (2) 6mm x 16mm Hex Bolts, (2) 6mm Lock Washers and (2) 6mm Flat Washers, **(Figure 46)**. Do not fully tighten hardware at this time.

Top mounted 30" bar style LED light (not included).

- a. Remove the (2) rubber plugs from the driver/left side mounting holes, **(Figure 47)**.
- b. Select the driver/left Light Bracket. Attach the Bracket to the top of the Bumper with (2) 8mm x 25mm Button Head Bolts, (4) 8mm Flat Washers, (2) 8mm Lock Washers and (2) 8mm Hex Nuts, **(Figure 47)**. Do not tighten hardware at this time.
- c. Repeat previous **Steps** to attach the passenger/right Bracket.
- d. Select the 30" light, (not included). Attach light to Top Brackets with the hardware included with the light. Adjust the width of the Brackets to the light and fully tighten bracket hardware.

IMPORTANT: Top Light Brackets are designed to install 30" bar style LED lights with outside length dimensions of 31.653" (804mm) to 32.44" (824mm) only. Fully tighten top light hardware once adjusted.

Outer LED cube style light installation (light not included).

- a. Attach lights to mounting tabs on back of each end of the Bumper, **(Figure 45)**.

24. With assistance, position the Bumper Assembly up to the inside of the Frame Brackets and reinstall Bumper, **(Figure 48 & 49)**. Level and adjust the Bumper and fully tighten all hardware.
25. Cut the overlapping ends on the fender flares to match the Bumper, **(Figure 50)**. Reattach fender flares and fender liners.
26. If front license plate is required, attach the License Plate Bracket to the holes in the Bumper with the included (2) 6mm x 20mm Button Head Screws, (4) 6mm Flat Washers and (2) 6mm Nylon Lock Nuts, **(Figure 51)**. Insert (2) Plastic Plugs into the square holes in the Bracket. Reuse the factory screws to attach the license plate to the plastic plugs.
27. Do periodic inspections to the installation to make sure that all hardware is secure and tight.

To protect your investment, Do not use any type of polish or wax that may contain abrasives that could damage the finish. Mild soap may be used to clean the Front Bumper assembly.

Driver/left Side Installation Pictured

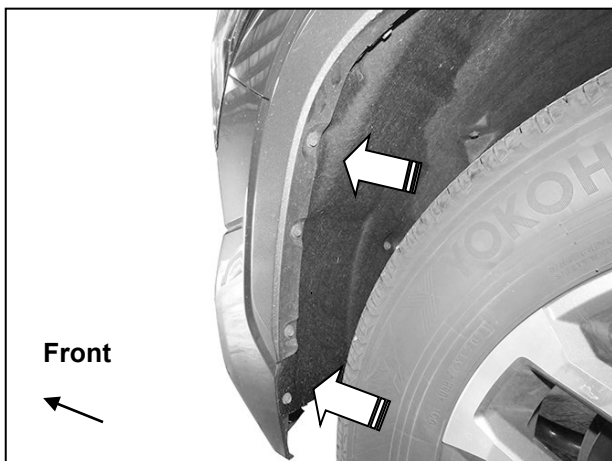

(Fig 1) Remove hardware attaching fender liner to fender and bumper (arrows)



(Fig 2) Models with fender flares, pull end of flare outward to release clips from body

Driver/left Side Installation Pictured

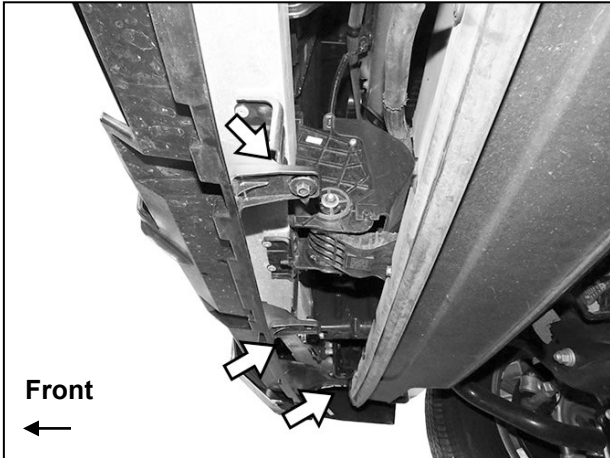

(Fig 3) Remove all hardware attaching bottom of bumper cover (arrows)



(Fig 4) Remove lower cover from bumper

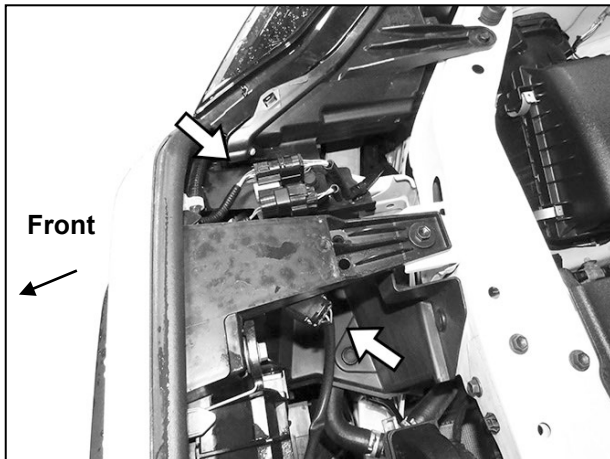

(Fig 5) Unplug all wiring harnesses leading to front bumper (passenger/right side pictured)



(Fig 6) Remove all hardware attaching top of grille and bumper cover to radiator core support (arrows) and remove grille/bumper cover assembly

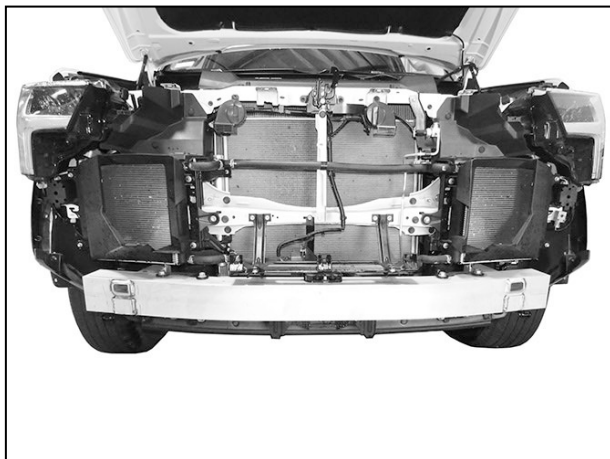

(Fig 7) Grille/bumper cover assembly removed

Driver/left Side Installation Pictured

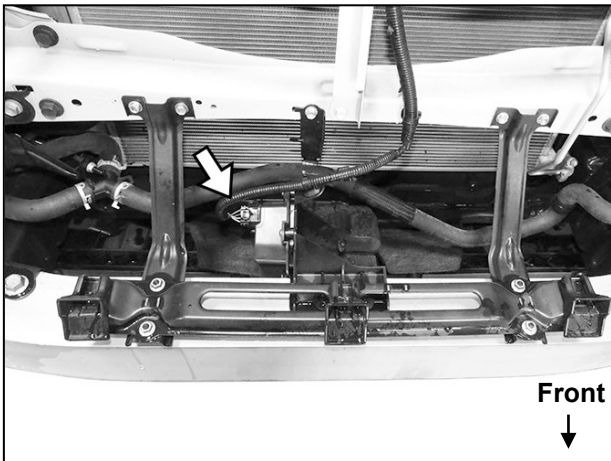

(Fig 8) Unplug active air dam motor (arrow)

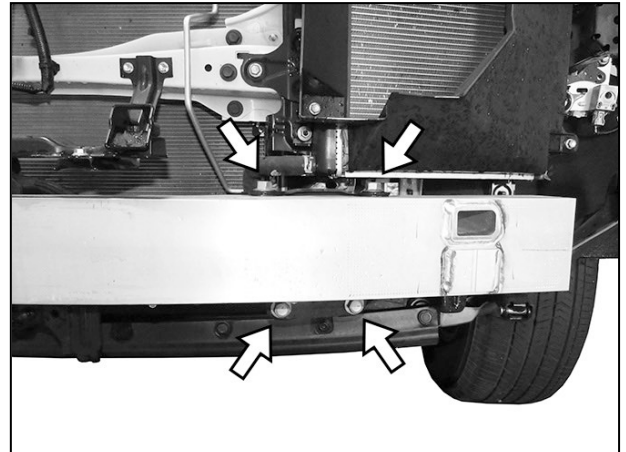

(Fig 9) Remove aluminum impact bumper from end of frame (arrows-driver/left side pictured)

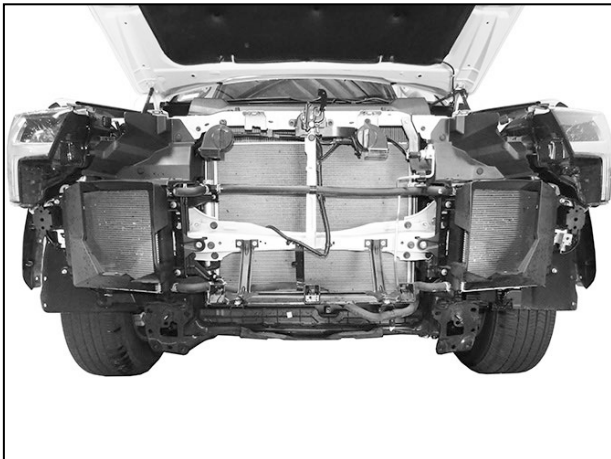

(Fig 10) Bumper, grille and impact bumper removed

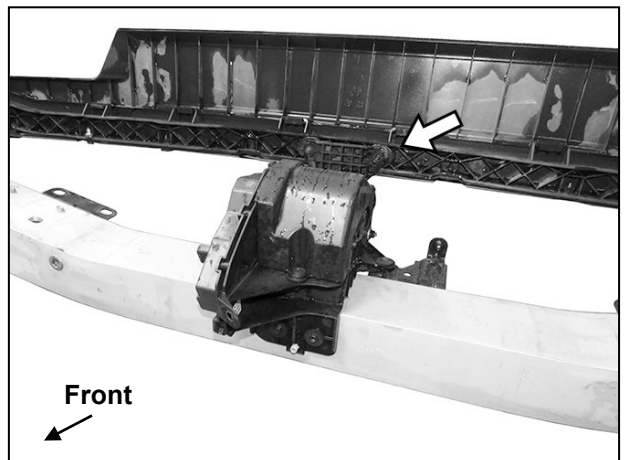

(Fig 11) Remove active air dam and motor assembly from impact bumper

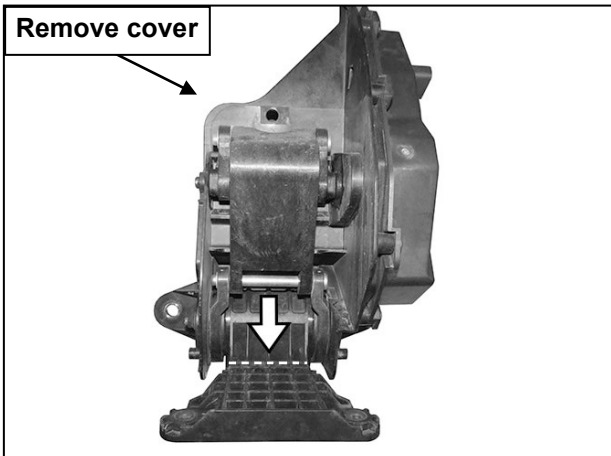

(Fig 12) Cut mounting tab off of drum (dashed line). Optional, disassemble motor to cut tab off of drum (see Fig 13-18)

Driver/left Side Installation Pictured

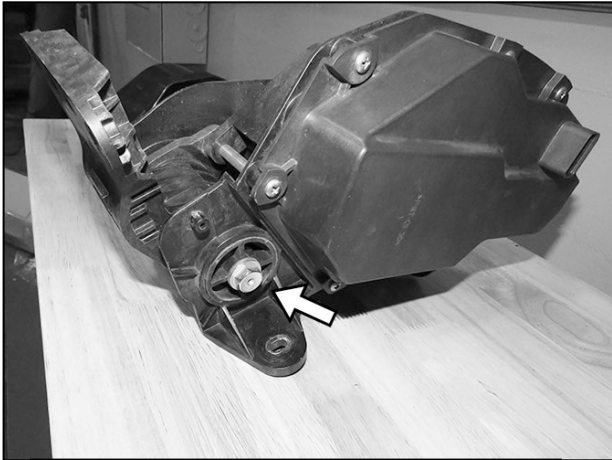

(Fig 13) Remove long pivot bolt (arrow)



**(Fig 14) Remove outer covers
and inner drive from both sides**

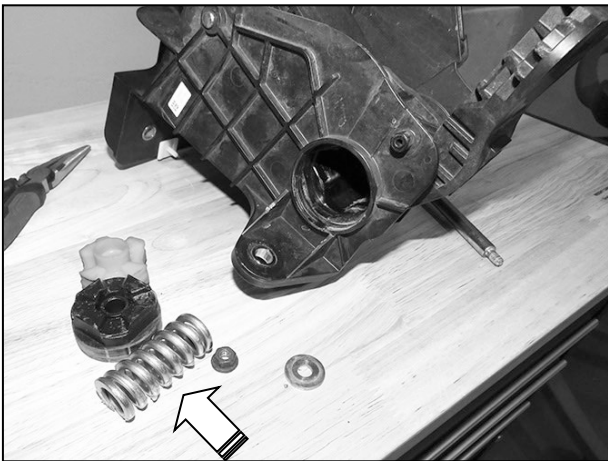

(Fig 15) Remove inner drive spring

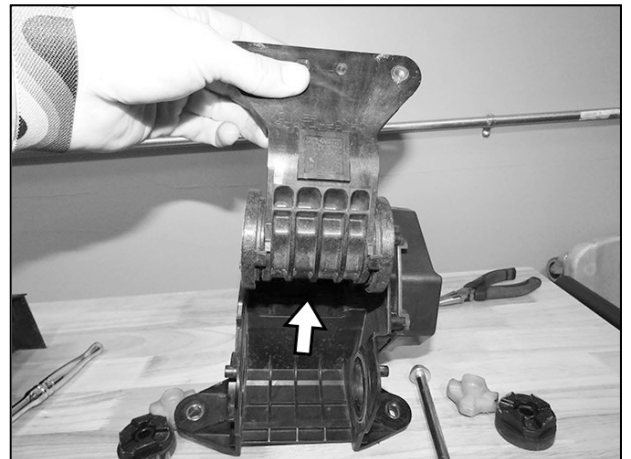

(Fig 16) Slide air dam bracket out of mount

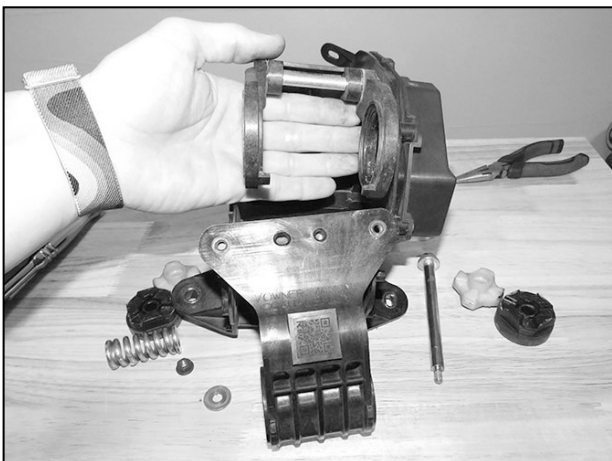

(Fig 17) Slide air dam bracket out of mount

Driver/left Side Installation Pictured

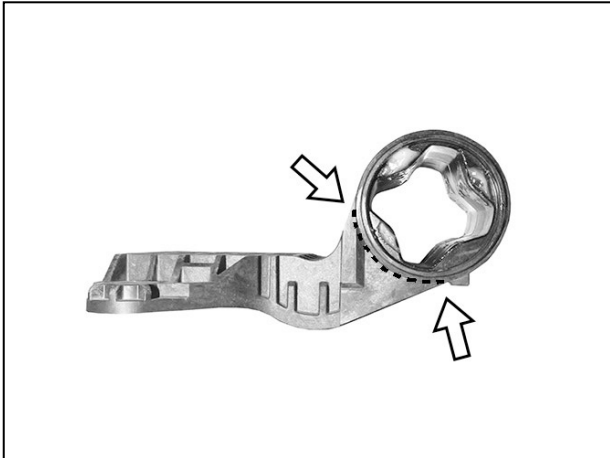

(Fig 18) Cut bracket off of drum (arrows). Reinstall drum section only

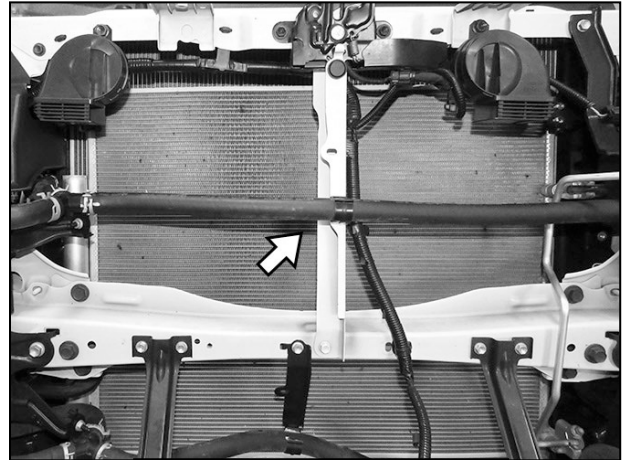

(Fig 19) Release hose from center support (arrow)

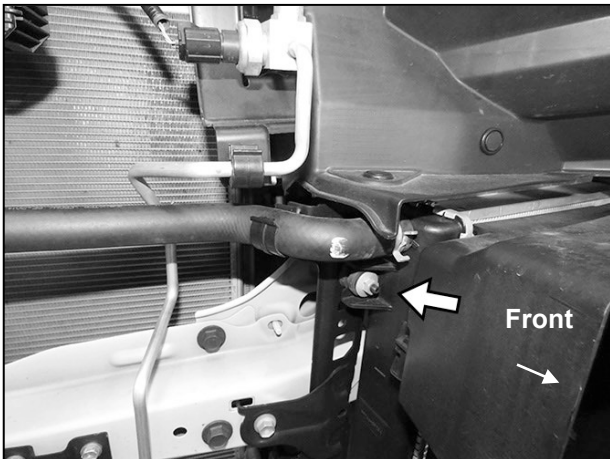

(Fig 20) Remove hardware attaching driver/left hose mounting bracket (arrow)

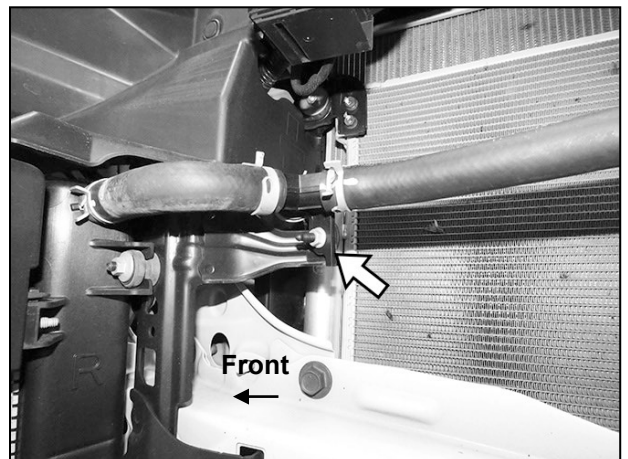

(Fig 21) Remove hardware attaching passenger/right hose mounting bracket (arrow)

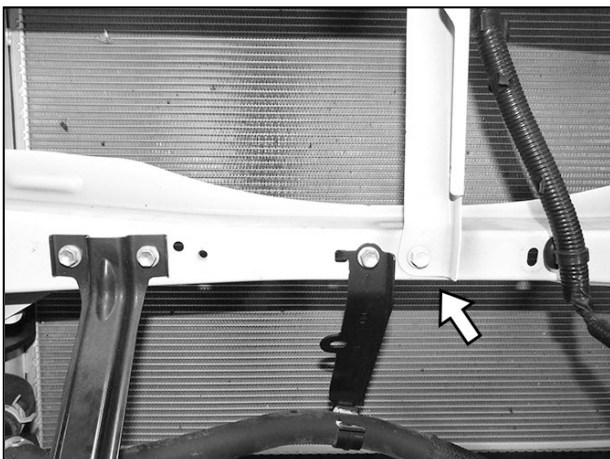

(Fig 22) Remove hex bolt attaching bottom of center support to crossmember (arrow)

Driver/left Side Installation Pictured

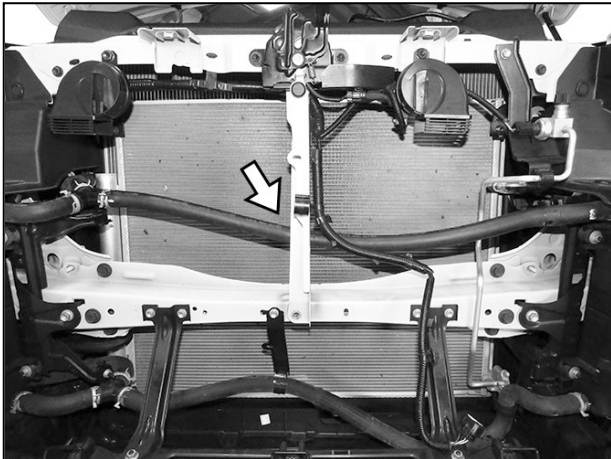

(Fig 23) Move hose under and behind center support (arrow) Reattach hose brackets

8mm x 50mm Hex Bolt
(2) 8mm Flat Washers
8mm Nylon Lock Nut

6mm x 50mm Hex Bolt
(2) 6mm Flat Washers
6mm Nylon Lock Nut

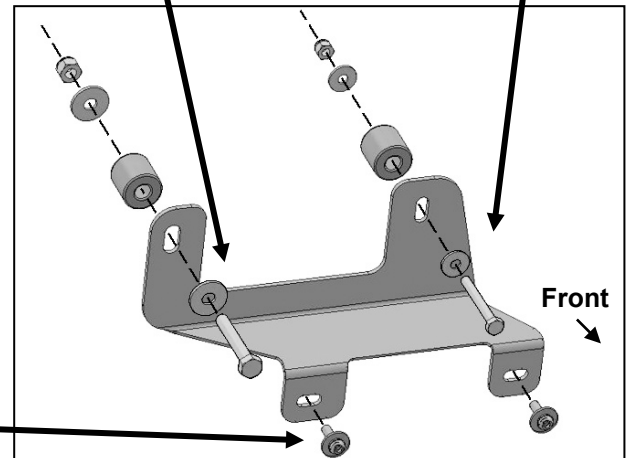

(2) 6mm Button Head
Combo Bolts with
oversized flat washers

(Fig 24) Attach air dam motor to back of Relocation Bracket. Insert Spacers between back of Bracket and air dam motor.

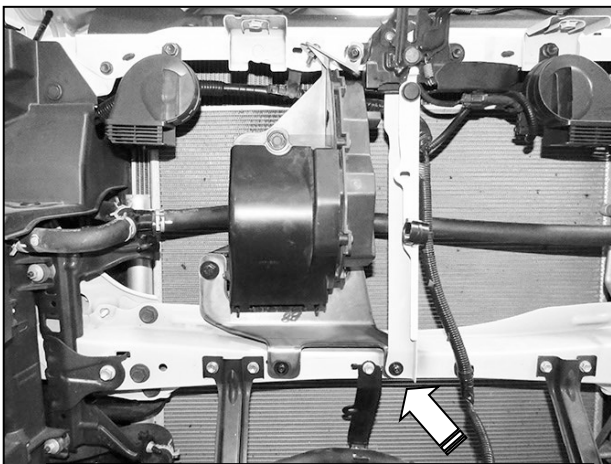

(Fig 25) Attach air dam motor Relocation Bracket to front of crossmember. Insert Bracket between center support and crossmember (arrow)

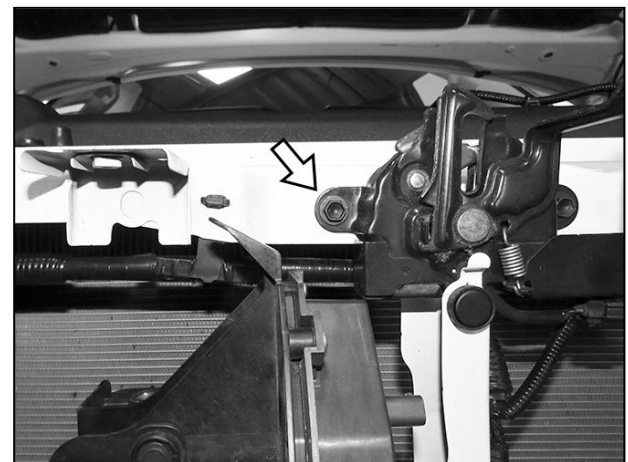

(Fig 26) Remove the hex bolt attaching hood release to core support (arrow)

Driver/left Side Installation Pictured

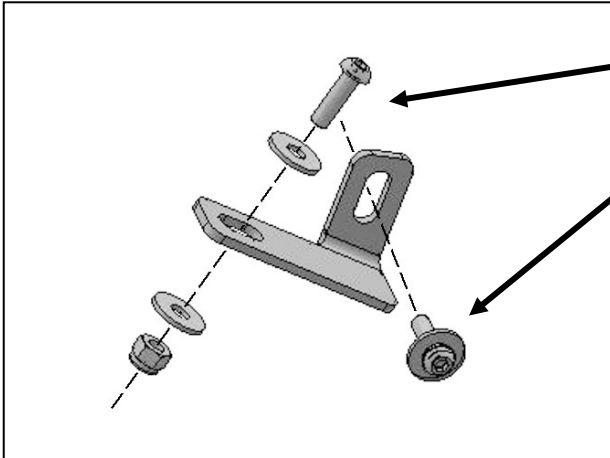

6mm x 20mm Button Head Bolt
(2) 6mm Flat Washers
6mm Nylon Lock Nut

6mm Button Head Combo Bolt
with oversized flat washer

(Fig 27) Attach Top Support Bracket to motor and core support

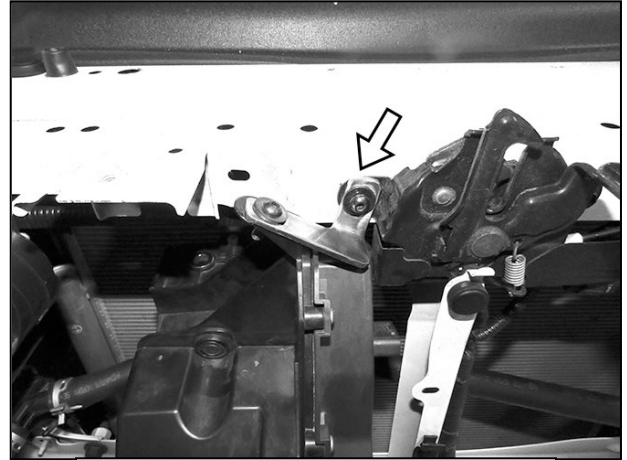

(Fig 28) Attach Top Support Bracket to motor and core support

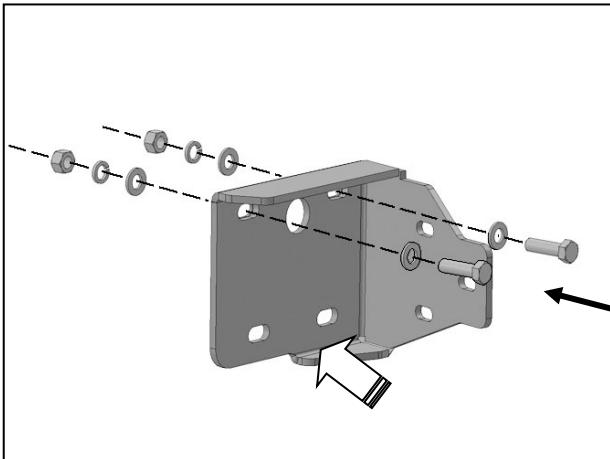

(2) 12mm x 40mm Hex Bolts
(4) 12mm Flat Washers
(2) 12mm Lock Washers
(2) 12mm Hex Nuts

(Fig 29) Reuse (2) factory hex bolts to attach bottom of Mounting Brackets to end of frame (arrow). Driver/left side Bracket illustrated

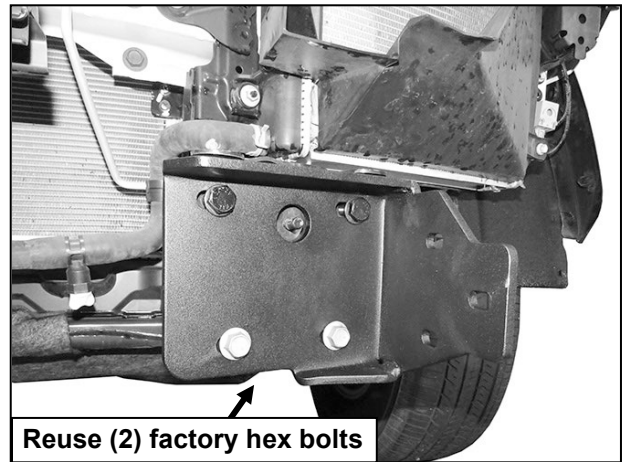

Reuse (2) factory hex bolts

(Fig 30) Driver/left Mounting Bracket installed

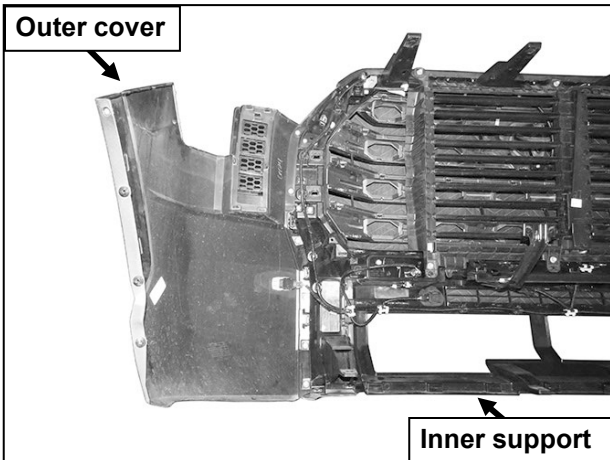

(Fig 31) Remove outer bumper covers and center bumper support from bottom of grille

Driver/left Side Installation Pictured



(Fig 32) Center grille body panel (fascia)

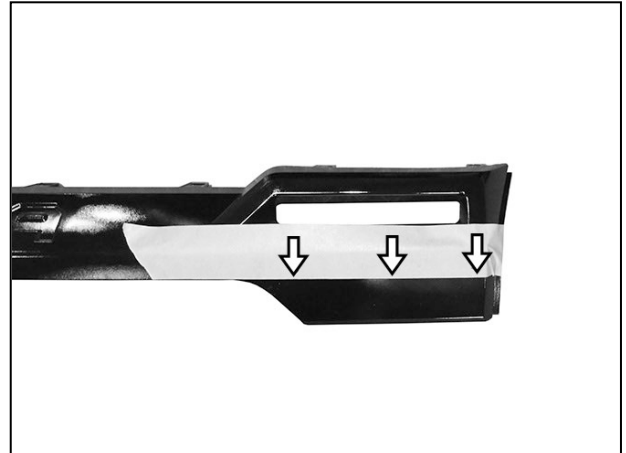

(Fig 33) Use masking tape to make a straight line from center outward. Cut along lines

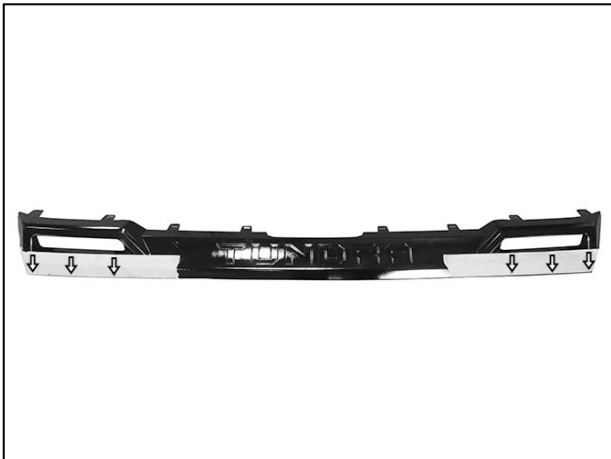

(Fig 34) Cut center grille body panel

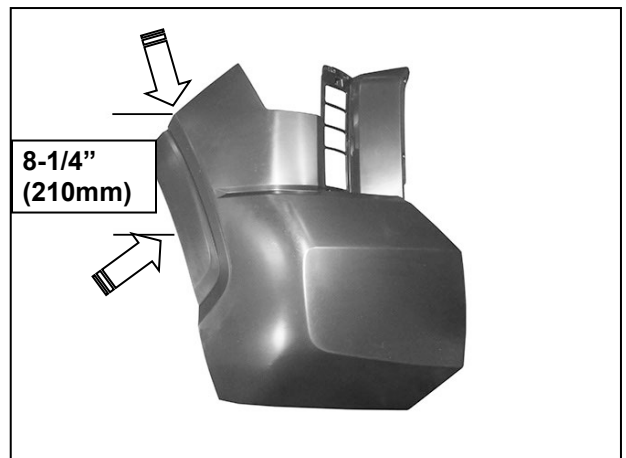

(Fig 35) Measure from bend in cover at flare down to wheel opening and place mark (arrows)

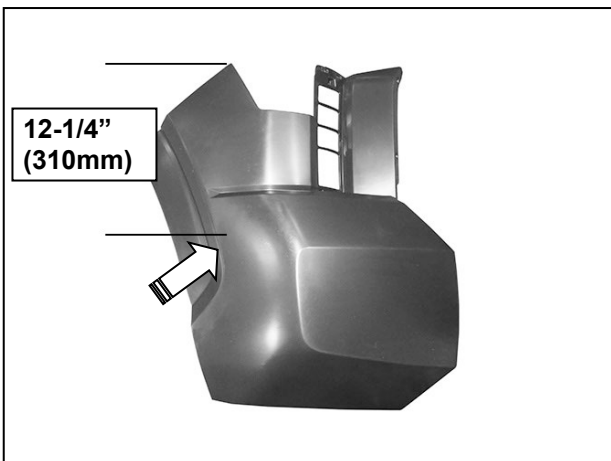

(Fig 36) Measure from point on cover straight down and place mark (arrow)

Passenger/right Side Installation Pictured

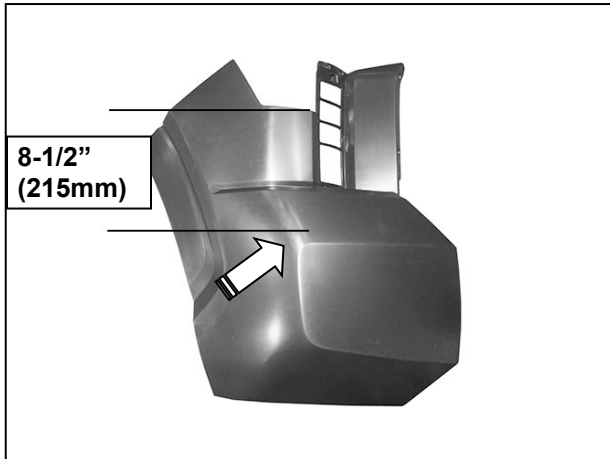

(Fig 37) Measure from headlight opening straight down and place mark (arrow)

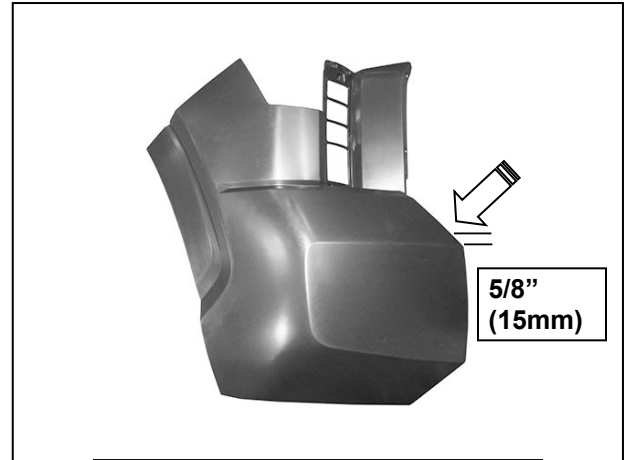

(Fig 38) Measure up from bend in cover and place mark (arrow)

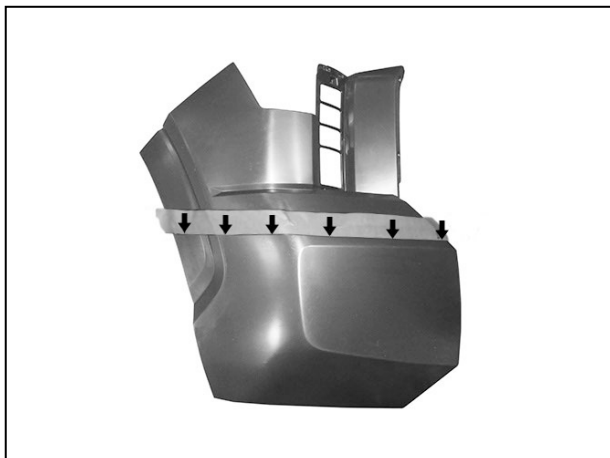

(Fig 39) Use masking tape to make a straight guide line and cut along previous marks. Temporarily reattach outer covers to grille and reinstall grille and center grille body panel

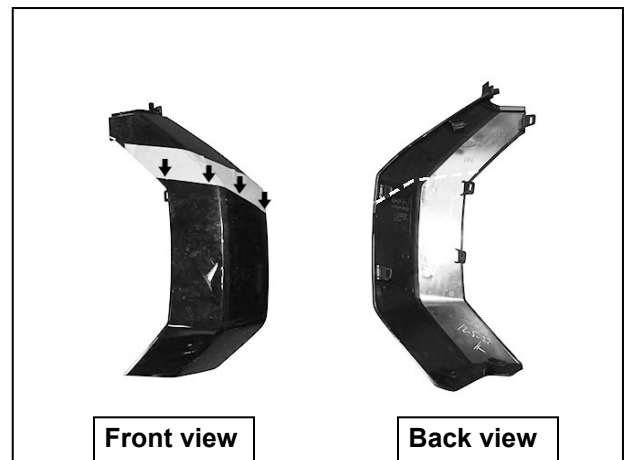

(Fig 40) Place bumper fill panel onto grille. Use masking tape to make a diagonal guide line connecting cut on outer bumper end cover and center body panel. Cut along tape

Driver/left Side Installation Pictured



(Fig 41) Use masking tape to make a diagonal guide line along bumper fill panel (see Fig 40) and cut bottom section off of inner bumper support along tape



(Fig 42) Inner bumper support cut along tape

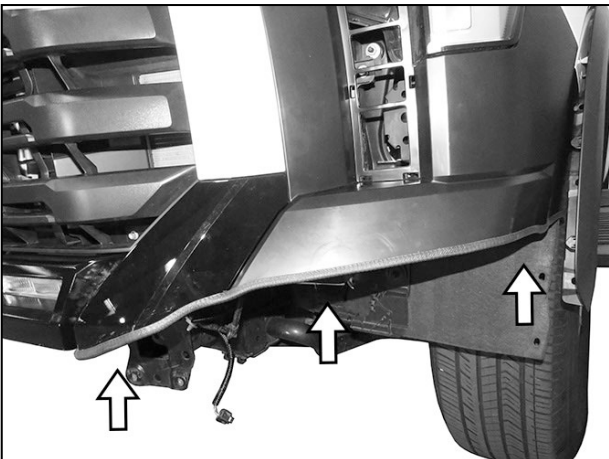

(Fig 43) Temporarily install Bumper (see Figures 48 and 49). Check fit between Bumper and trim plastic as necessary. Clean up cut sections and push Edge Trim onto cut bumper covers and fill panels (arrows)



(Fig 44) Reinstall grille/bumper assembly

Driver/left Side Installation Pictured

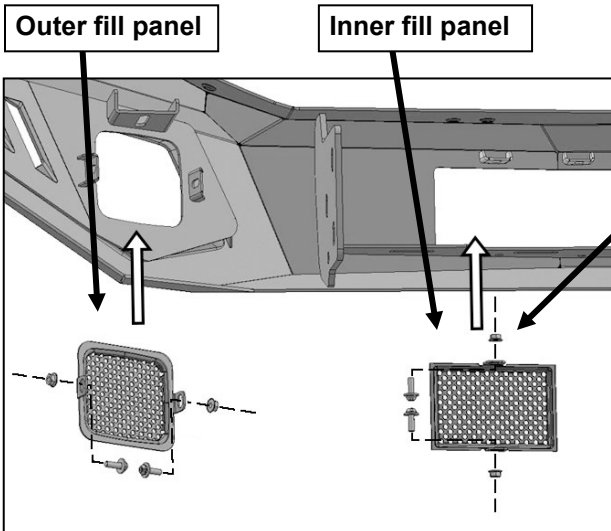

(Fig 45) Attach Mesh Fill Panels as desired to fill unused openings for lights (lights not included)

- 6mm Button Head Combo Bolts
- 6mm Flange Hex Nuts

- 8mm x 16mm Hex Bolt
- 8mm Lock Washer
- 8mm Flat Washer

- 8mm x 25mm Hex Bolt
- (2) 8mm Flat Washers
- 8mm Lock Washer
- 8mm Hex Nut

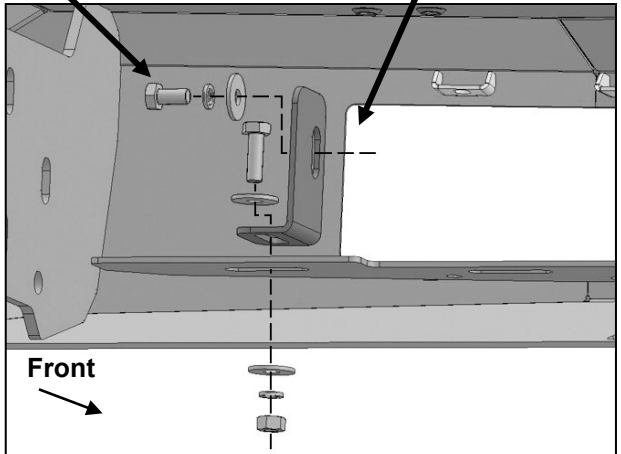

(Fig 46) Bracket illustration is a suggestion only. Brackets are offset to allow adjustment for all widths of lights

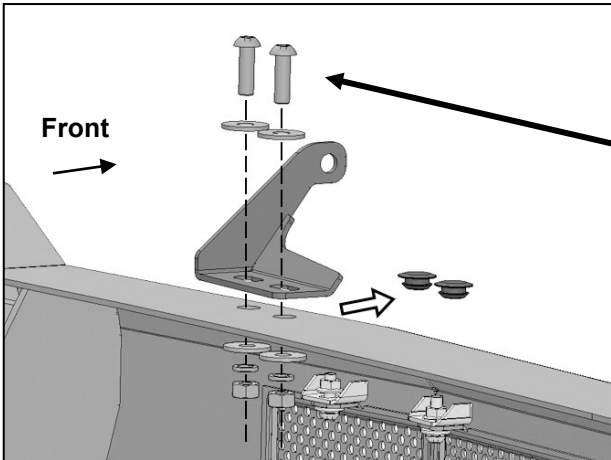

(Fig 47) Remove rubber plugs to attach Top Light Bracket to Bumper

- (2) 8mm x 25mm Button Head Bolts
- (4) 8mm Flat Washers
- (2) 8mm Lock Washers
- (2) 8mm Hex Nuts

- (3) 10mm x 35mm Hex Bolts
- (6) 10mm Flat Washers
- (3) 10mm Lock Washers
- (3) 10mm Hex Nuts

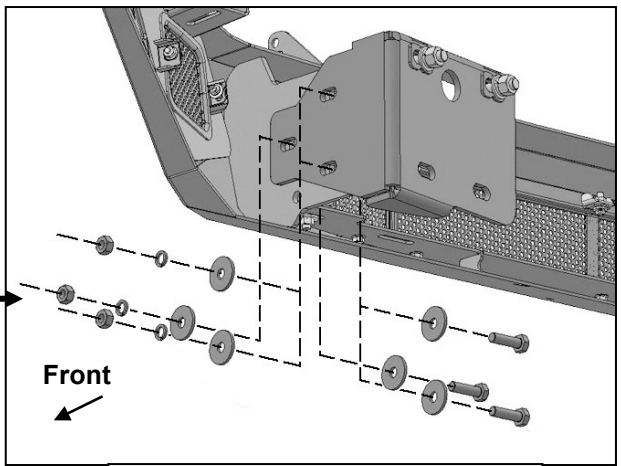

(Fig 48) Attach Bumper to inside of driver/left side Frame Bracket

Driver/left Side Installation Pictured

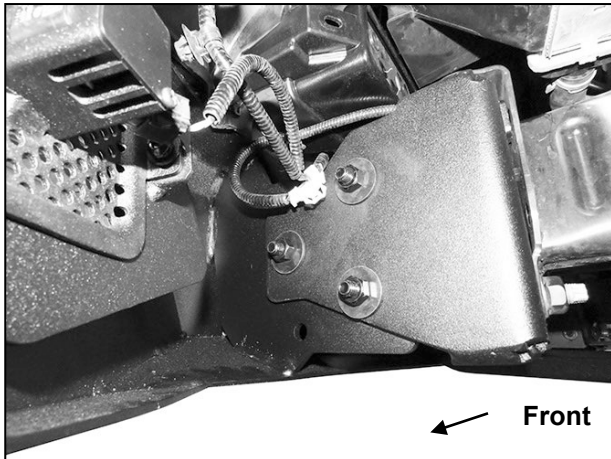

(Fig 49) Driver/left side of Bumper installation pictured from below

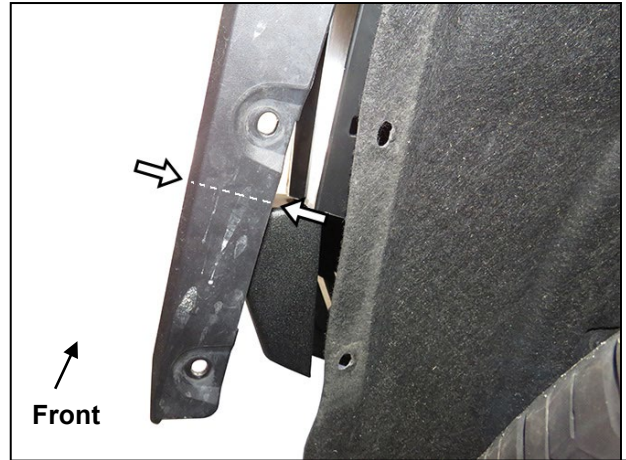

(Fig 50) Cut end of fender flares to match Bumper. Reattach fender flare and fender liner

- (2) 6mm x 20mm Button Head Screws
- (4) 6mm Flat Washers
- (2) 6mm Nylon Lock Nuts

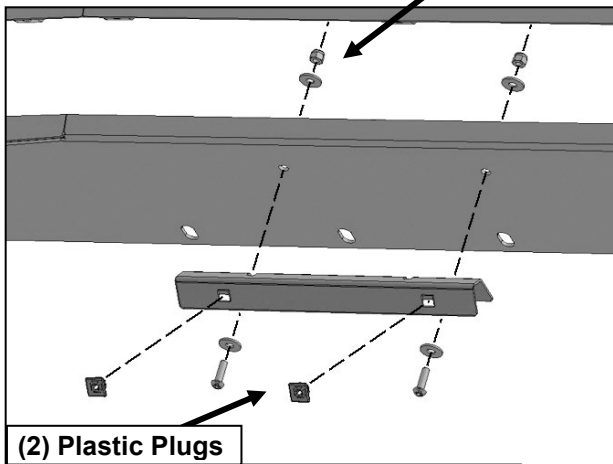

(2) Plastic Plugs

(Fig 51) Attach License Plate Bracket to Front Bumper



Complete Installation. Additional accessories pictured not included