



# INSTALLATION INSTRUCTIONS

## PRO SERIES REAR BUMPER

### APPLICATION:

2016-2021 Toyota Tacoma (Excl. Vehicles with Blind Spot Monitoring System)

PART NUMBER: 58-421045  
58-421045

CONTENT			
ITEM	QUANTITY	DESCRIPTION	TOOLS NEEDED
1	1	REAR BUMPER	17MM SOCKET
2	1	DRIVER MAIN BRACKET	17MM WRENCH
3	1	PASSENGER MAIN BRACKET	10MM SOCKET
4	10	M8 FLAT WASHER (BLACK ZINC)	10MM WRENCH
5	4	M8 SPLIT LOCK WASHER (BLACK ZINC)	PLYER TOOL
6	4	SENSOR PLUG	RATCHET
7	4	M12 SPLIT LOCK WASHER (YELLOW ZINC)	TORQUE WRENCH
8	4	M12 SERRATED FLANGE BOLT (YELLOW ZINC)	ELECTRICAL TAPE
9	8	M12 FLAT WASHER (YELLOW ZINC)	
10	4	M12 HEX NUT (YELLOW ZINC)	
11	2	M6 FLAT WASHER (BLACK ZINC)	
12	2	M6 SERRATED FLANGE NUT	
13	2	M6 BUTTON HEAD BOLT (BLACK ZINC)	

**ANTI-SEIZE LUBRICANT MUST BE USED ON ALL STAINLESS STEEL FASTENERS TO PREVENT THREAD DAMAGE AND GALLING**

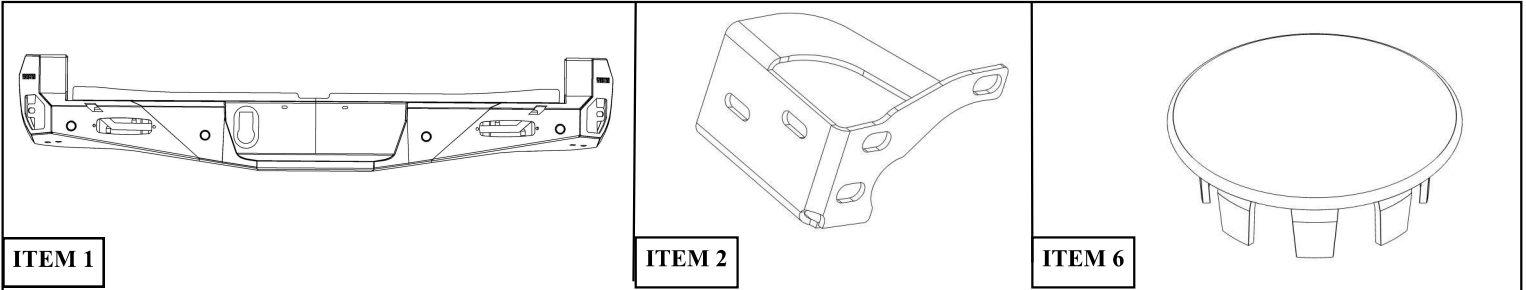

**Note:**  
This bumper is not compatible with blind spot monitoring system.

## PROCEDURE

1. Remove contents from box, verify if all parts listed are present and free from damage. Carefully read and understand all instructions before attempting installation.  
**Failure to identify damage before installation could lead to a rejection of any claim.**
2. Disconnect all electrical connectors attached to rear bumper. (Two plugs, sensors harness, etc.). To remove the sensors—push on tabs holding sensor to plastic and then push sensor out of the hole. Disconnect the sensor by unlocking the connector with a flat head screwdriver. Pay attention to the orientation of the sensors. They must be installed in the same orientation. Handle sensors with care, they are very delicate . *See Figure 1*
3. **After making sure all electrical connections are disconnected**, start popping out the trim clips along the bottom of the bumper by pulling out the centers. *Note: A trim removal tool may help with this. See Figure 2-4*

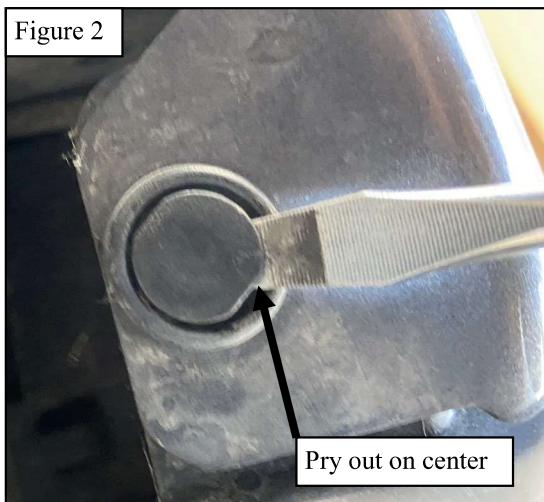
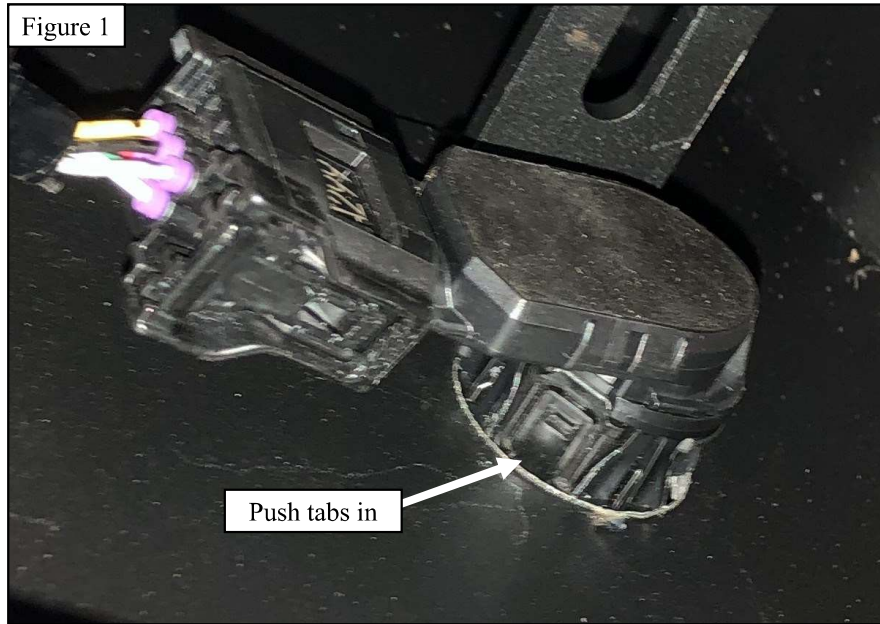



4. After all clips are removed, pull up on the plastic trim, starting from the outsides. Remove the trim to expose the metal frame.
5. Unbolt the metal bumper frame from the truck frame and remove. **See Figure 5-6.**
6. Remove the Blind spot monitors (BSM) , if equipped.

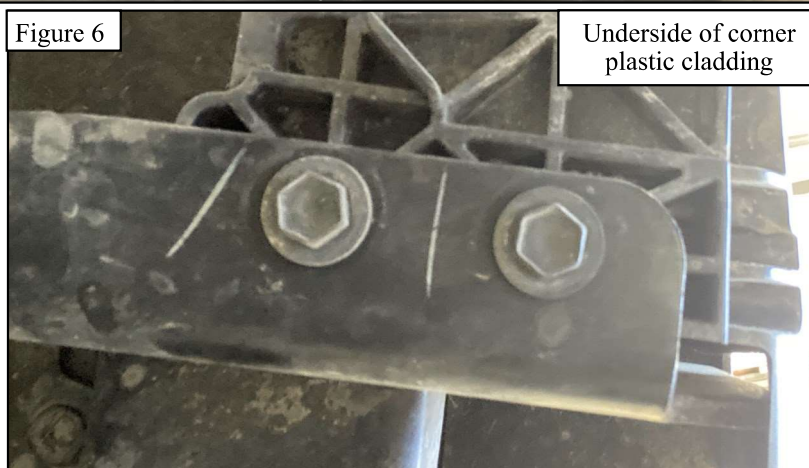
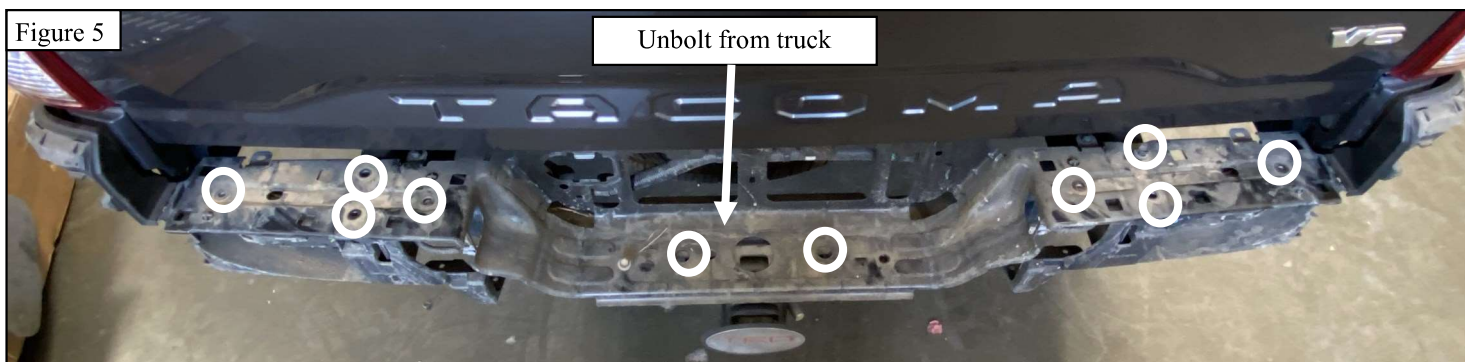

7. Mount the bumper brackets to the frame re-using the factory hardware. See Figure 7

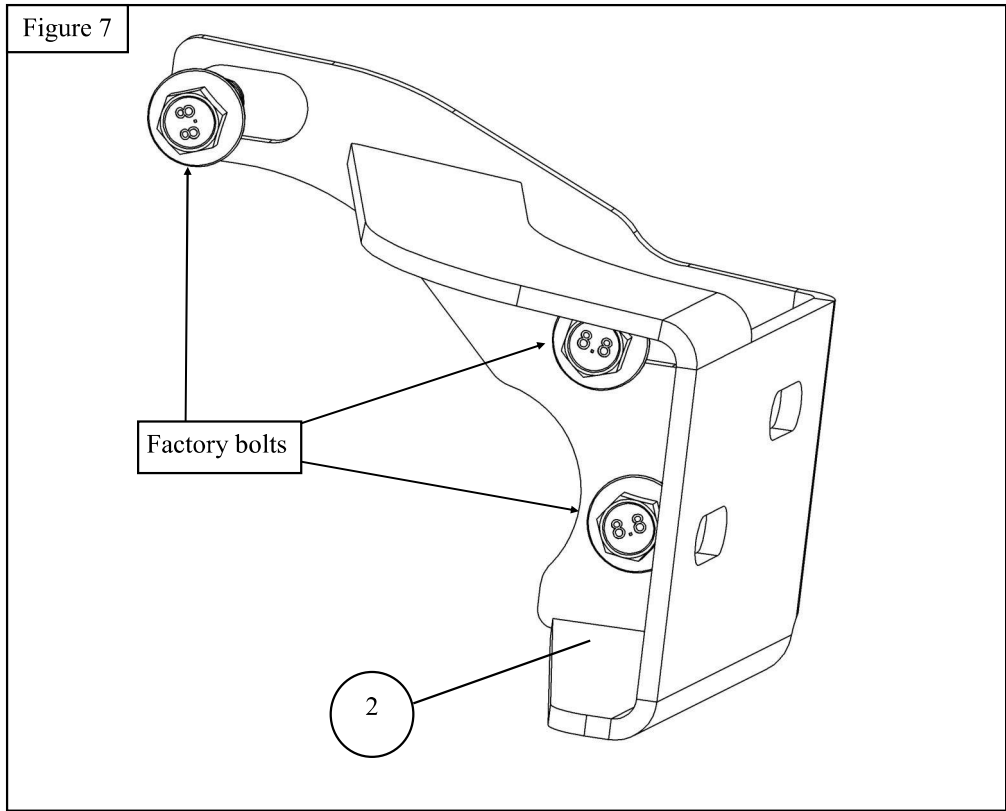

8. Using the supplied M12 hardware, loosely install bumper to frame brackets. See Figure 8.

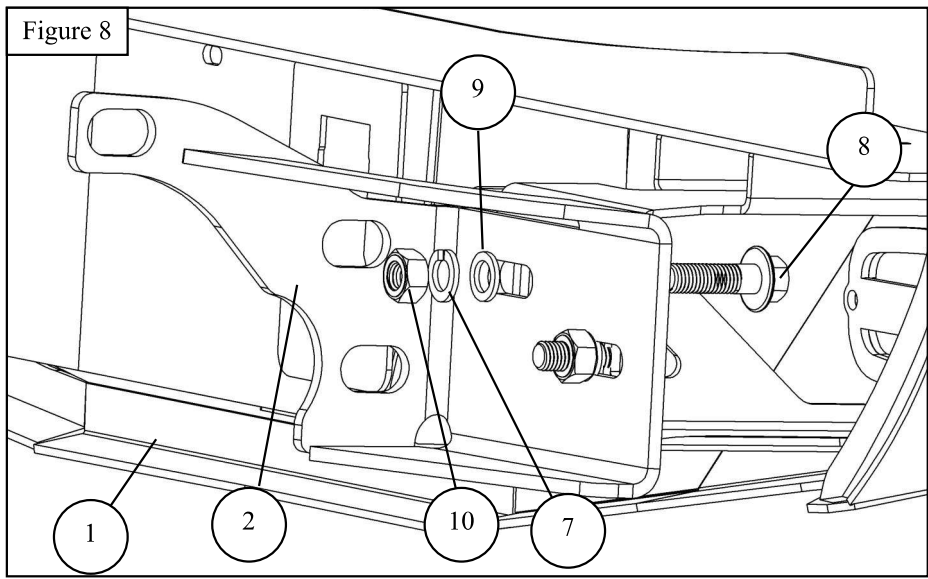

**WARNING .**

**After you have mounted bumper on main brackets. CAREFULLY open tailgate. While tailgate is open, adjust the height of the bumper so that it has about 3/8" of clearance with respect to the tailgate. Then tighten all M12 hardware to 50-55 ft-lbs.**

9. Mount the license plate and tow plug, and accessory lighting at this time.

**PARKING SENSOR INSTALLATION**

**\*If not installing sensors, install Hole Plugs (4) into holes on bumper and proceed.**

10. Re-install the sensors by pressing them into the holes on the bumper. Make sure the orientation is correct.

11. Carefully route the harness around the bumper.

Note: Zip ties or double sided tape can be used to route harness and to hold the sensor in position.

Figure 11

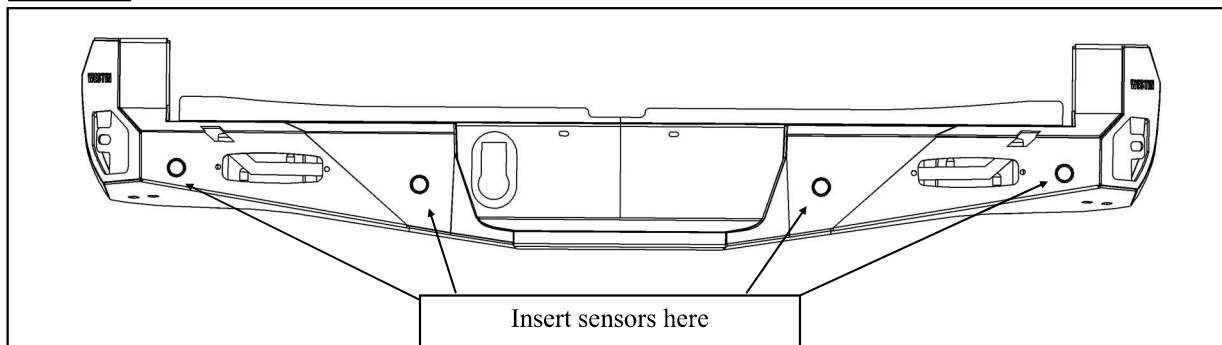

## License plate lights installation.

1. Disconnect the battery from your vehicle.
  2. Locate the license plate lights (pre-installed) in the bumper. Pop out the lights by squeezing the clips in on the backside.  
**See Figure 8**
  3. Locate the factory wiring for the license plate lights. Strip back the wiring on the factory harness and supplied light. Using connectors, crimp the red wire on the positive factory wire and the black wire to the factory ground wire. **See Figure 9**
- Note: Only the portion shown on **Figure 10** will be needed from the connector.

Figure 8

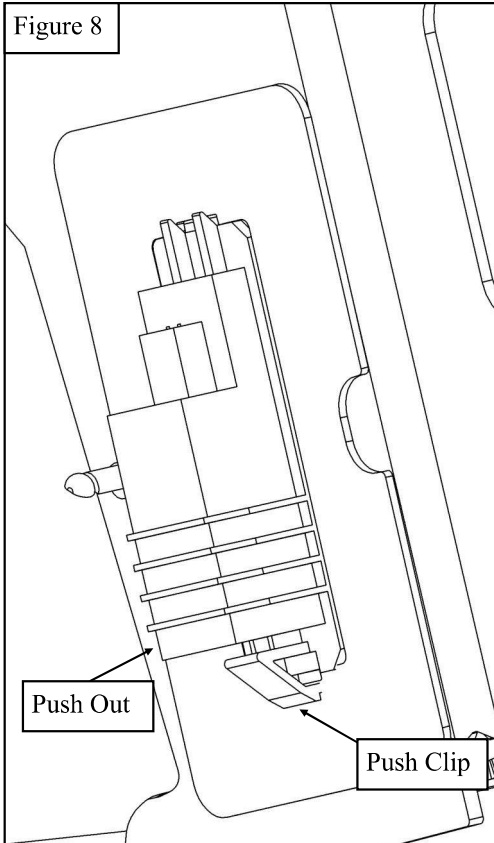
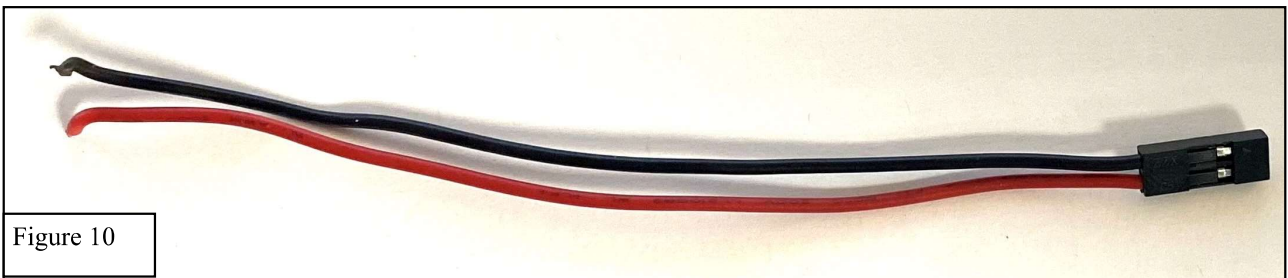

Figure 9



Figure 10



4. Push the light back in until it clips into place. Repeat on the opposite side. **See Figure 14**

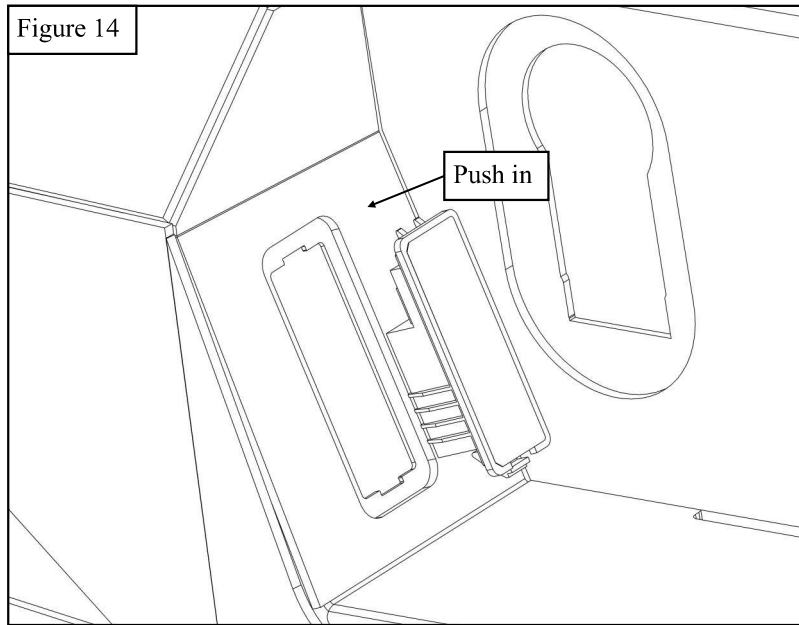

5. If you are installing the optional reverse lights, remove the mesh covers and install the optional lights with the M6 hardware. **See Figure 15**
6. Locate the factory wiring for the reverse lights. Strip back the wiring on the factory harness and supplied light. Using connectors, crimp the red wire on the positive factory wire and the black wire to the factory ground wire.
7. Reconnect your battery.

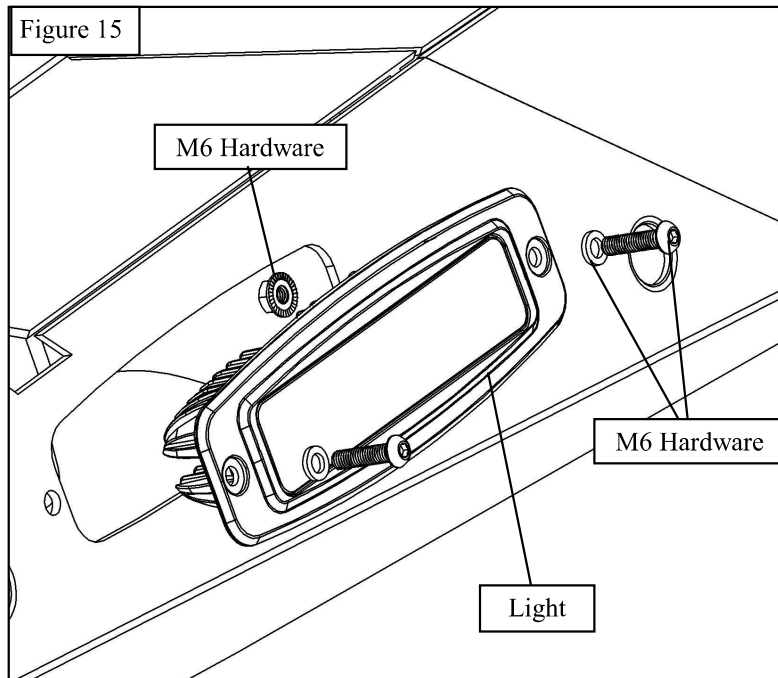

**INSTALLATION COMPLETE**



**CARE INSTRUCTIONS**

- REGULAR WAXING IS RECOMMENDED. DO NOT USE ANY TYPE OF POLISH OR WAX THAT MAY CONTAIN ABRASIVES.
- STAINLESS STEEL PRODUCTS CAN BE CLEANED WITH MILD SOAP AND WATER. STAINLESS STEEL POLISH SHOULD BE USED TO POLISH SMALL SCRATCHES.
- GLOSS BLACK FINISHES SHOULD BE CLEANED WITH MILD SOAP AND WATER.

**WESTIN** Westin Automotive Products, Inc.  
320 W. Covina Blvd  
San Dimas, Ca. 91773

Thank you for choosing Westin products  
for additional installation assistance please call  
Customer Service (800) 793-7846  
[www.westinautomotive.com](http://www.westinautomotive.com)





## WARNING



Failure to follow these instructions could lead to death, personal injury, and / or property damage.

### FASTENERS:

All Westin supplied fasteners must be utilized and installed in accordance with the installation instructions and apply torque to the specifications as defined. **DOUBLE CHECK ALL FASTENERS BEFORE INITIAL USE, AND PERIODICALLY IN THE FUTURE TO ENSURE PROPER FUNCTION AND SAFETY.**

### DRILLING:

Most Westin products do not require drilling for installation. If drilling is defined as required, use caution when drilling a vehicle. **FAILURE TO REVIEW AN AREA TO BE DRILLED MAY RESULT IN PERSONAL INJURY AND/OR INJURY TO OTHERS AS WELL AS VEHICLE DAMAGE.**

### EYE PROTECTION:

**ALWAYS WEAR SAFETY GLASSES OR GOGGLES DURING THE INSTALLATION PROCESS TO AVOID PERSONAL INJURY.**

### MAXIMUM TOWING/CARRYING CAPACITY:

The Westin Receiver Hitches will have a visible tow rating label affixed directly on the product. User should never exceed the vehicle manufacturers maximum tow and weight rating regardless of the capacity of the hitch. **FAILURE TO FOLLOW THESE GUIDELINES WILL VOID THE WESTIN WARRANTY AND MAY RESULT IN PERSONAL INJURY AND/OR INJURY TO OTHERS AS WELL AS VEHICLE DAMAGE.**