

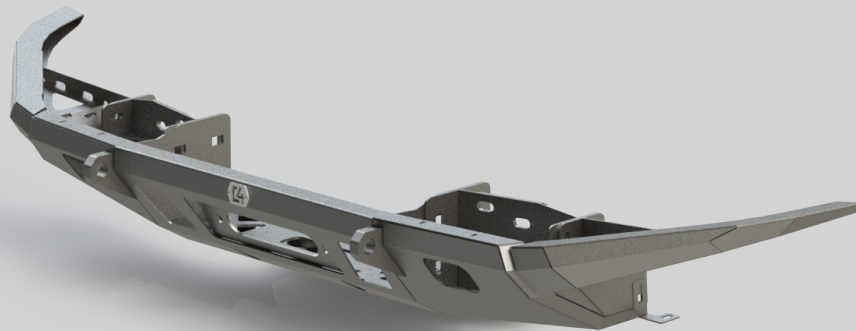

Installation Instructions

2024+ Tacoma Lo-Pro High-Clearance Side Additions



Before You Begin

Scan or click on this QR code to take you to the 2024+ Tacoma Lo-Pro install video. Once on the product page, click the instructions tab (Figure 1).



Figure 1: Instructions tab on the Lo-Pro Bumper product page.

Step 1 - Prepare for the Cut

Whether you already have your lo-pro bumper installed or you will be installing it at the same time as your HCSA's, the cut line for the HCSA's will be marked while the bumper cover is still on the truck.

Step 2 - Measure

Lay a piece of masking tape on the bumper cover as seen in Figure 2. Then, measure straight down from the body line at the points shown in Figure 2 and mark the tape with a sharpie.

Measurements:

1. 5-3/8"
2. 5-1/2"
3. 5-5/8"

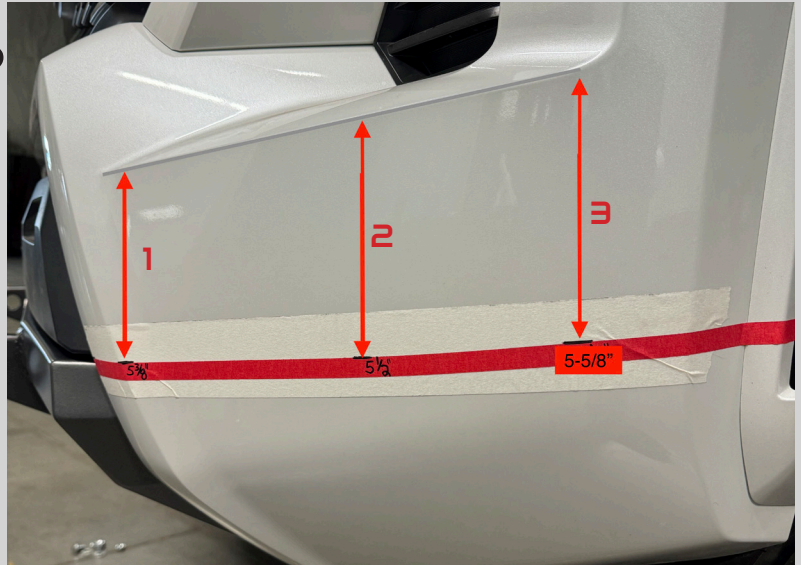

Figure 2: Masking tape on the bumper cover with measurements from the sharp body line shown with the grey line.

Step 3 - Measure

Measure straight down and mark the flair to be cut as shown in Figure 3.

Measurements:

3. 5-5/8"
4. 6-3/4"

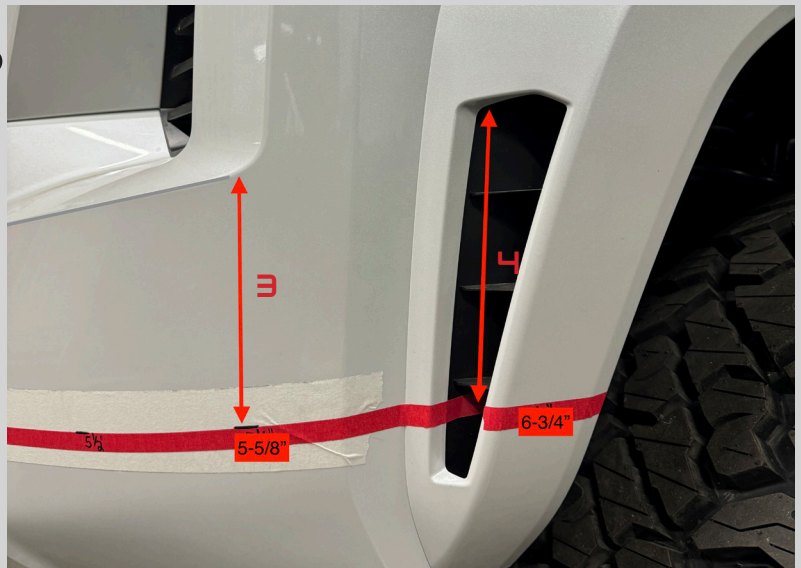

Figure 3: Fender flare measurement (#4) with measurement #3 from previous step.

Step 4 - Connect the Dots

Take a sharpie and make a mark on the tape that lines up with the lower corners of the black center portion of the bumper cover (Figure 4). Next, take a new piece of masking tape (ideally about 1/2" wide) and use it to connect the marks that you made in the previous steps. Continue this line across the flare and towards the center of the bumper. Make sure that the tape makes a straight line between the marks and it continues straight to the edge of the flare. This will be your cut line. Make sure the cut line is not going to hit the parking sensors if the truck has them.



Figure 4: Mark at the lower corner of the black center portion of the bumper cover and 1/2" masking taper connecting the measurement points.

Step 5 - Make the Cut

If you are installing the Lo-Pro bumper at the same time, refer to the install video for it above for instructions on cutting the bumper cover. You will want to make that cut first, then cut the sides for the HCSA's. Just make sure you leave the tape that we applied in the previous step on the bumper cover and the fender flare.

If you already have the Lo-Pro bumper installed on your truck and have the factory bumper cover on, you can make the cut while on the truck. Just make sure to not hit the Lo-Pro bumper with your cutting tool. See Figure 5 for reference of the cut bumper cover.

Next, cut the fender flare along the cutline.



Figure 5: The bumper cover is cut for both the Lo-Pro bumper and High-Clearance Side Additions.

Step 6 - Install

the Lo-Pro

Install the Lo-Pro bumper according to the instruction video (Figure 6). Do not reinstall the plastic bumper cover yet!

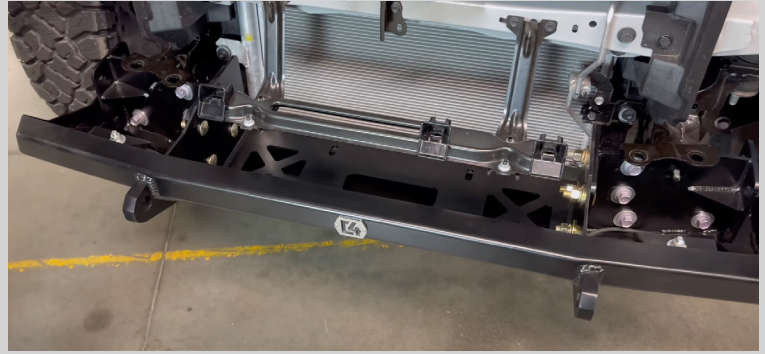

Figure 6: Lo-Pro installed.

Step 7 - Install the HCSA's

Install the HCSA's onto the frame brackets using the supplied hardware. Loosely install all of the hardware as shown in Figure 7. Next, align the top of the HCSA mounting plate flush with the top of the frame mounting bracket and snug the two rear nuts to hold the HCSA in place. Leave the front two nuts loose at this time.

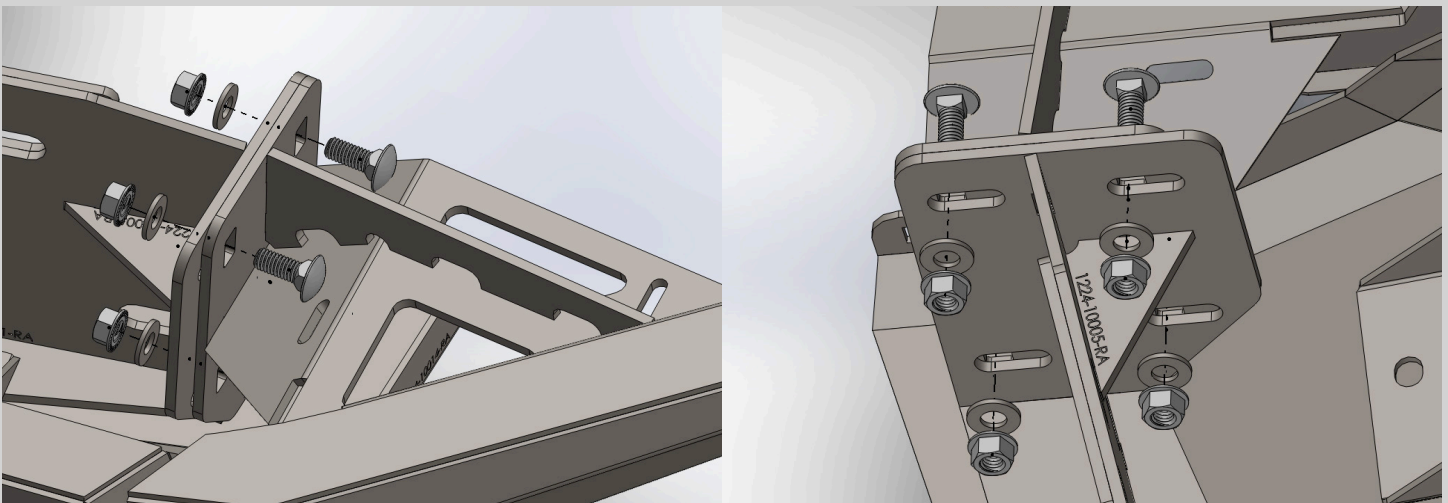

Figure 7: Hardware to mount HCSA's to the frame brackets.

Step 8 - Reinstall the Bumper Cover

Reinstall the bumper cover as shown in the Lo-Pro install video.

Step 9 - Adjust

Check the fitment of the HCSA's and Lo-Pro to the bumper cover and make any necessary adjustments. The HCSA's can be rotated if the gap between it and the bumper cover is larger or smaller at one end. There should be about a $3/8$ " to $1/2$ " gap between the HCSA's and the bumper cover (Figure 8). Once everything looks good, tighten down all of the hardware.



Figure 8: Lo-Pro and High-Clearance Side Additions adjusted with a $3/8$ " gap.

Step 10 - Fender Liners

Push the front of the fender liners up so they are against the HCSA's and they do not protrude into the wheelwell. Secure them to the HCSA's by drilling a 1/4" hole through the liner and bolting them to the HCSA using the supplied 1/4" hardware (Figure 9).



Figure 9: Fender liners secured to the HCSA's using the supplied 1/4" hardware.

Step 11 - Side Cover

Install the side cover using the 3/8" hardware from the Lo-Pro hardware pack (Figure 10).

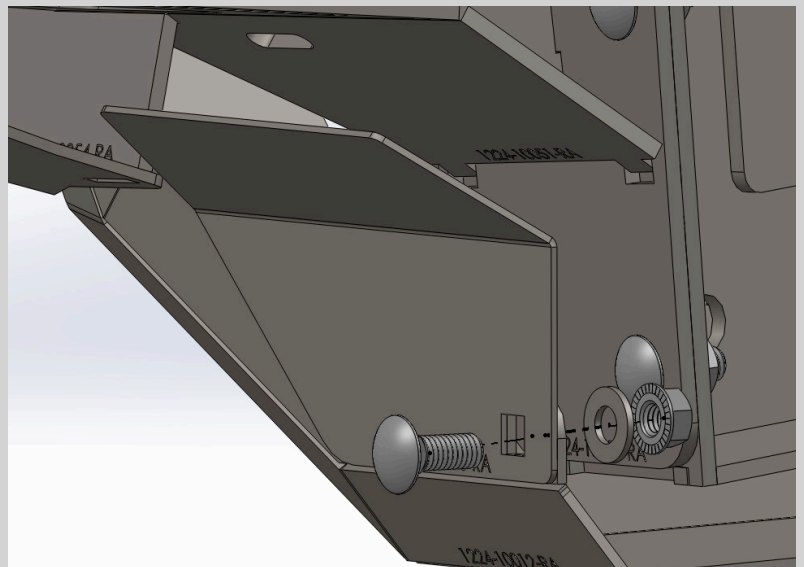

Figure 10: Side cover installation.

**PROVEN ARMOR
FOR EVERY ADVENTURE**



FABRICATION