

7929 Lincoln Ave. Riverside, CA 92504
 Phone: 951.689.ICON | Fax: 951.689.1016

PART #	DESCRIPTION
52050	TOYOTA REAR 8.0" U-BOLT KIT

COMPONENTS INCLUDED	
N/A	
HARDWARE INCLUDED	
(4) 159689 8.0" SQ TOP UBOLT 9/16-18 W/NUTS /WASHERS/TACO/TUNDRA/COLORADO	
TOOLS REQUIRED	
JACK JACK STANDS TORQUE WRENCH	7/8" SOCKET / WRENCH 19MM SOCKET / WRENCH
TECH NOTES	
N/A	

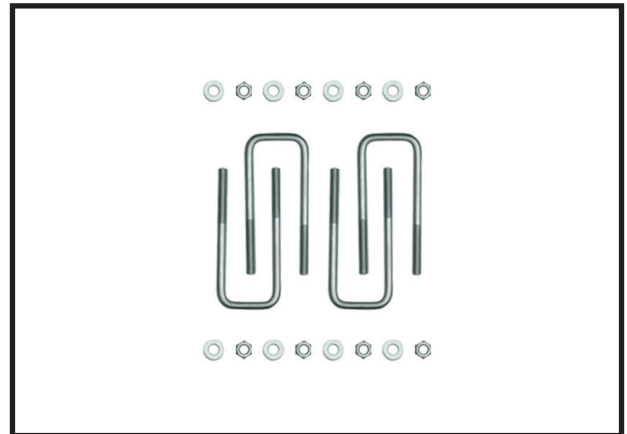

WARNING!
<p>** READ ALL INSTRUCTIONS THOROUGHLY FROM START TO FINISH BEFORE BEGINNING INSTALLATION! IF THESE INSTRUCTIONS ARE NOT PROPERLY FOLLOWED SEVERE FRAME, SUSPENSION AND TIRE DAMAGE MAY RESULT TO THE VEHICLE!</p> <p>** ICON VEHICLE DYNAMICS RECOMMENDS THAT YOU EXERCISE EXTREME CAUTION WHEN WORKING UNDER A VEHICLE THAT IS SUPPORTED WITH JACK STANDS.</p> <p>** ICON VEHICLE DYNAMICS RECOMMENDS ALL INSTALLATION TO BE PERFORMED BY A PROFESSIONAL SHOP/SERVICE TECHNICIAN. PRODUCT FAILURE CAUSED BY IMPROPER INSTALLATION WILL NOT BE COVERED UNDER ICON'S WARRANTY POLICY.</p>

INSTALLATION

- Using a properly rated jack, raise the rear of the vehicle and support the frame rails with jack stands. Ensure the jack stands are secure and set properly before lowering the jack. NEVER WORK UNDER AN UNSUPPORTED VEHICLE. Remove the rear wheels.
- Remove the lower rear shock bolts using a 19mm socket/wrench.
- Use a jack to support the axle then loosen and remove the driver side U-bolts using a 19mm socket/wrench. Make sure the axle is well supported or it could fall when the U-bolts are removed.
- Slowly lower the axle away from the springs. Make desired changes to leaf spring. Refer to leaf spring install instructions.
- Use a jack to raise the axle and guide the spring center pin into the hole on the top of the axle. Install supplied U-bolts washers and nuts using a 7/8" socket/wrench. [Torque to 90ft-lbs]
- Repeat steps 2-5 on opposite side of the vehicle.
- Reinstall shock to the factory lower shock mount using a 19mm socket/wrench. [Torque to factory spec]
- Reinstall wheels and lower to the ground. [Torque to factory spec]

VERIFY ALL FASTENERS ARE PROPERLY TORQUED BEFORE DRIVING VEHICLE.

RETORQUE ALL NUTS, BOLTS AND LUGS AFTER 100 MILES AND PERIODICALLY THEREAFTER.

ICON VEHICLE DYNAMICS LIMITED LIFETIME WARRANTY

ICON Vehicle Dynamics warrants to the original retail purchaser who owns the vehicle on which the product was originally installed. ICON Vehicle Dynamics does not warrant the product for finish, alterations, modifications and/or installation contrary to ICON Vehicle Dynamics instructions. ICON Vehicle Dynamics products are not designed, nor are they intended to be installed on vehicles used in race applications, for racing purposes or for similar activities. (A "race" is defined as any contest between two or more vehicles, or a contest of one or more vehicles against the clock, whether or not such contest is for a prize). This warranty does not include coverage for police or taxi vehicles, race vehicles, or vehicles used for government or commercial purposes. Also excluded from this warranty are sales outside of the United States of America and Canada.

ICON Vehicle Dynamics' obligation under this warranty is limited to the repair or replacement, at ICON Vehicle Dynamics' discretion, of the defective product. Any and all costs of removal, installation or re-installation, freight charges and incidental or consequential damages are expressly excluded from this warranty. Items that are subject to wear are not considered defective when worn and are not covered.

ICON Vehicle Dynamics components must be installed as a complete kit as shown in our current application guide. Any substitutions or exemptions of required components will immediately void the warranty. Some finish damage may happen to parts during shipping and is not covered under warranty.

This warranty is expressly in lieu of all other warranties expressed or implied. This warranty shall not apply to any product that has been improperly installed, modified or customized subject to accident, negligence, abuse or misuse.



ICON VEHICLE DYNAMICS®
PERFORMANCE SUSPENSION SYSTEMS AND SHOCK ABSORBERS

7929 Lincoln Ave. Riverside, CA 92504 Phone: 951.689.ICON Fax: 951.689.1016
www.iconvehicledynamics.com



FOLLOW US ON FACEBOOK!



7929 Lincoln Ave. Riverside, CA 92504
Phone: 951.689.ICON | Fax: 951.689.1016

PART #	DESCRIPTION
56103	05-UP TACOMA REAR AIR BUMP SYSTEM

COMPONENTS INCLUDED	
(2) 204902 2.0 AIR BUMP 2.5 TRAVEL 1:1 (1) 154015 BUMP STOP MOUNT (PASS) (1) 154016 BUMP STOP MOUNT (DRVR)	(2) 154018 BUMP STOP STRIKER PLATE (1) 56103H HARDWARE KIT
HARDWARE INCLUDED	
56103H HARDWARE KIT	
(2) 209000 SLEEVE 2.25 X 2.010 X .630 (4) 605052 1/4-20 NYLOCK NUT (4) 605057 1/4-20 X 2.000 SCREW (8) 605202 7/16-14 X 1.250 SCREW	(8) 605220 7/16-14 NYLOCK NUT (16) 605230 7/16 SAE FLAT WASHER (2) 605970 VIBRATITE ANTI SEIZE TUBE
TOOLS REQUIRED	
JACK JACK STANDS GRINDER W/ CUT-OFF WHEEL AIR CHISEL	1/4" SOCKET / WRENCH 5/8" SOCKET / WRENCH 7/16" SOCKET / WRENCH TORQUE WRENCH
TECH NOTES	
<p>1. FAILURE TO INSTALL BUMP STOP SPACER SLEEVE IF LEAF SPRING PACK IS LESS THAN 2.50" THICK MAY RESULT IN SHOCK AND/OR FRAME DAMAGE.</p> <p>2. APPLY ANTISEIZE TO THE BUMP STOP CYLINDER BEFORE INSERTING INTO THE BRACKET. FAILURE TO APPLY ANTISEIZE MAY CAUSE BUMP STOP TO GET STUCK IN THE BRACKET.</p> <p>3. IF USING A U-BOLT FLIP KIT, ICON STRIKER PLATE (56105) IS REQUIRED.</p> <p>4. YOUR ICON BUMP STOP ASSEMBLIES COME FACTORY CHARGED TO 100 PSI. PLEASE CONSULT ICON PRIOR TO MAKING ANY NITROGEN PRESSURE CHANGES.</p>	

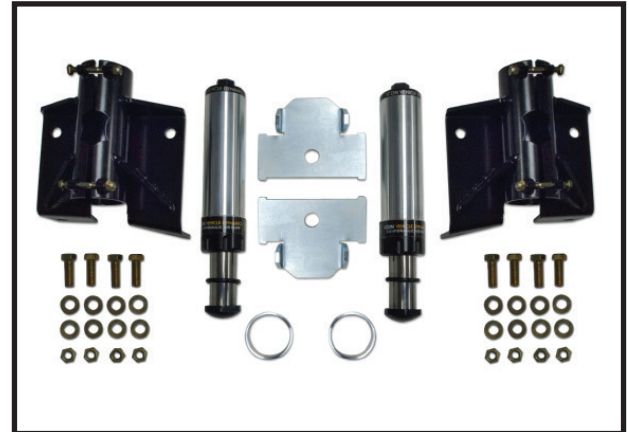

WARNING!
<p>** READ ALL INSTRUCTIONS THOROUGHLY FROM START TO FINISH BEFORE BEGINNING INSTALLATION! IF THESE INSTRUCTIONS ARE NOT PROPERLY FOLLOWED SEVERE FRAME, SUSPENSION AND TIRE DAMAGE MAY RESULT TO THE VEHICLE!</p> <p>** ICON VEHICLE DYNAMICS RECOMMENDS THAT YOU EXERCISE EXTREME CAUTION WHEN WORKING UNDER A VEHICLE THAT IS SUPPORTED WITH JACK STANDS.</p> <p>** ICON VEHICLE DYNAMICS RECOMMENDS ALL INSTALLTION TO BE PERFORMED BY A PROFESSIONAL SHOP/SERVICE TECHNICIAN. PRODUCT FAILURE CAUSED BY IMPROPER INSTALLATION WILL NOT BE COVERED UNDER ICON'S WARRANTY POLICY.</p>

INSTALLATION

- Using a properly rated jack, raise the rear of the vehicle and support the frame rails with jack stands. Ensure the jack stands are secure and set properly before lowering the jack. NEVER WORK UNDER AN UNSUPPORTED VEHICLE. Remove the front wheels.
- Remove the bump stop striker plate from the frame. There are 4 rivets attaching the striker plate to the frame that must be removed. The recommended rivet removing method is as follows although some people have other methods. Grind an "X" in the rivet head with a slitting disk. Using an air hammer or hammer and cold chisel shear the head off the rivet. Grind any exposed rivet shank as flush as possible. At this point you can start to pry the bracket to start to loosen it. Using a flat nose drift punch hammer the rivet out. If the rivet starts to expand in the hole and lock in you will have to center drill the rivet to release the pressure. [FIGURE 1 & 2]

FIG.1



FIG.2



- With the bracket removed position the new air bump bracket on the frame. It is designed to use the existing rivet holes. Bolt it to the frame using (4) 7/16 x 1.5" bolts, nuts and washers per side.
- Install the new striker plate on leaf spring. Support the axle with a jack. Remove the u-bolts and remove the stock rubber bump stop. If you are doing a leaf pack install in conjunction with the bump stops you can do that at this time. Position the striker plate on top of the leaf pack with the lower support arms up against the side of the leaf pack and install new u-bolts. If you are using a u-bolt flip kit on your vehicle, please purchase the u-bolt flip kit striker plate (56105).
- Apply antiseize to the bump stop cylinder before sliding it into the bracket.

NOTE: Due to manufacturing differences between years, some models require minor trimming of the rib on the bed for sufficient bump stop clearance with the 5/8" spacer removed.

6. Install the hydraulic air bump. Install the 1/4" bolts and nuts in the bump bracket pinch rings but do not tighten. Slide the 5/8" long spacer ring on the bump stop and slide the bump stop up into the bracket. Tighten the pinch bolts to retain the bump stop. If you are using a leaf pack assembly that is thicker than 2.50" the 5/8" spacer ring can be removed to get full up travel of the suspension. Removing the bump stop spacer with a leaf spring pack that is thinner than 2.50" will result in shock and/or frame damage.

7. Reinstall the wheels and lower the vehicle back to the ground. [Torque to factory spec]

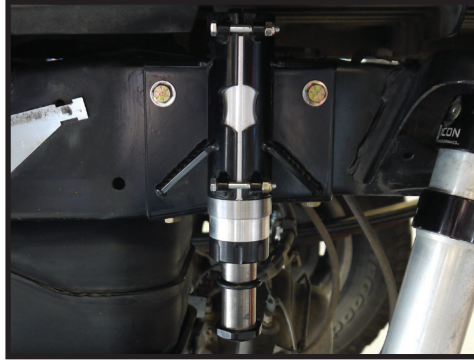

VERIFY ALL FASTENERS ARE PROPERLY TORQUED BEFORE DRIVING VEHICLE.

RETORQUE ALL NUTS, BOLTS AND LUGS AFTER 100 MILES AND PERIODICALLY THEREAFTER.

ICON VEHICLE DYNAMICS LIMITED LIFETIME WARRANTY

ICON Vehicle Dynamics warrants to the original retail purchaser who owns the vehicle on which the product was originally installed. ICON Vehicle Dynamics does not warrant the product for finish, alterations, modifications and/or installation contrary to ICON Vehicle Dynamics instructions. ICON Vehicle Dynamics products are not designed, nor are they intended to be installed on vehicles used in race applications, for racing purposes or for similar activities. (A "race" is defined as any contest between two or more vehicles, or a contest of one or more vehicles against the clock, whether or not such contest is for a prize). This warranty does not include coverage for police or taxi vehicles, race vehicles, or vehicles used for government or commercial purposes. Also excluded from this warranty are sales outside of the United States of America and Canada.

ICON Vehicle Dynamics' obligation under this warranty is limited to the repair or replacement, at ICON Vehicle Dynamics' discretion, of the defective product. Any and all costs of removal, installation or re-installation, freight charges and incidental or consequential damages are expressly excluded from this warranty. Items that are subject to wear are not considered defective when worn and are not covered.

ICON Vehicle Dynamics components must be installed as a complete kit as shown in our current application guide. Any substitutions or exemptions of required components will immediately void the warranty. Some finish damage may happen to parts during shipping and is not covered under warranty.

This warranty is expressly in lieu of all other warranties expressed or implied. This warranty shall not apply to any product that has been improperly installed, modified or customized subject to accident, negligence, abuse or misuse.



ICON VEHICLE DYNAMICS®
PERFORMANCE SUSPENSION SYSTEMS AND SHOCK ABSORBERS

7929 Lincoln Ave. Riverside, CA 92504 Phone: 951.689.ICON Fax: 951.689.1016
www.iconvehicledynamics.com



FOLLOW US ON FACEBOOK!



2.0 BUMP STOP TECHNICAL INFORMATION

MAINTENANCE

ICON shock absorbers are a high quality rebuildable race style shock absorber designed for optimal performance. With a unit of this caliber on your vehicle, routine maintenance is required to keep them looking and operating in like new condition. Residual oil and assembly lube may be present at all seal paths from the factory out of the box and is considered normal. Pooling of oil however is not acceptable at any time and one should contact the ICON dealer where purchased.

BELOW ARE GUIDELINES BASED ON HOW YOU USE YOUR VEHICLE BUT YOUR MILEAGE MAY VARY:

STREET USE:

- Send in for factory servicing every 40,000 miles or if a leak develops, ride quality decreases, or they begin to make excessive noise.
- Remove any buildup of road salt, mud, or debris from shocks anytime accrued
- Clean with mild soap and water with each oil change or anytime you notice build up.
- Wax the cylinders yearly with automotive wax to prevent corrosion.
- Check nitrogen pressure yearly. (252004 charge needle assembly available at any ICON distributor)

STREET/DIRT:

- Send in for factory servicing every 15,000 miles or if a leak develops, ride quality decreases, or they begin to make excessive noise.
- Clean with mild soap and water with each oil change, offroad trip, or anytime you notice build up.
- Wax the cylinders yearly with automotive wax to prevent corrosion.
- Check nitrogen pressure each dirt outing. (252004 charge needle assembly available at any ICON distributor)

DIRT USE:

- Send in for factory servicing every 1,000 miles.
- Check nitrogen pressure each outing. (252004 charge needle assembly available at any ICON distributor)
- Remove any buildup of mud or debris from shocks after every outing.

SELF-SERVICE:

- Contact ICON for service kits & tools at (951) 689-4266.

PRODUCT REGISTRATION

Please visit: <http://www.iconvehicledynamics.com/tech-support/registration/> to register your product.

ICON VEHICLE DYNAMICS SHOCK ABSORBER WARRANTY

This shock absorber has a 1 year warranty against any manufacturer's defects. If a shock fails within the initial year of ownership, the shock must be shipped to ICON Vehicle Dynamics for inspection and service. If a shock is inspected and it has been determined the shock failed due to neglect, damage caused by improper installation or any other reason besides "normal wear and tear", the owner of said shock is responsible for all service costs. This includes labor, parts, and shipping.

ICON Vehicle Dynamics warrants to the original retail purchaser who owns the vehicle on which the product was originally installed. ICON Vehicle Dynamics does not warrant the product for finish, alterations, modifications and/or installation contrary to ICON Vehicle Dynamics instructions. ICON Vehicle Dynamics products are not designed, nor are they intended to be installed on vehicles used in race applications, for racing purposes or for similar activities. (A "race" is defined as any contest between two or more vehicles, or a contest of one or more vehicles against the clock, whether or not such contest is for a prize). This warranty does not include coverage for police or taxi vehicles, race vehicles, or vehicles used for government or commercial purposes. Also excluded from this warranty are sales outside of the United States of America and Canada.

ICON Vehicle Dynamics' obligation under this warranty is limited to the repair or replacement, at ICON Vehicle Dynamics' discretion, of the defective product. Any and all costs of removal, installation or re-installation, freight charges and incidental or consequential damages are expressly excluded from this warranty. Items that are subject to wear are not considered defective when worn and are not covered.

ICON Vehicle Dynamics components must be installed as a complete kit as shown in our current application guide. Any substitutions or exemptions of required components will immediately void the warranty. Some finish damage may happen to parts during shipping and is not covered under warranty.

This warranty is expressly in lieu of all other warranties expressed or implied. This warranty shall not apply to any product that has been improperly installed, modified or customized subject to accident, negligence, abuse or misuse.

To send a shock in for warranty please visit our website <http://www.iconvehicledynamics.com/tech-support/shock-service/>

7929 Lincoln Ave. Riverside, CA 92504
 Phone: 951.689.ICON | Fax: 951.689.1016

PART #	DESCRIPTION
57826CP	05-UP TACOMA RXT REAR 2.5 RR CDCV PAIR

COMPONENTS INCLUDED	
(2) 154885RC 05+ TACO RXT REAR 2.5 VS CDCV (2) 250003 RESERVOIR MOUNTING PLATE (2) 605131 3/8" SPLIT LOCK WASHER	(2) 605144 3/8-12 X .750 SELF TAP BOLT (2) 611008 RXT HEAVY DUTY STEM BUSHING KIT (1) 611051 HOSE CLAMP KIT
HARDWARE INCLUDED	
611008 STEM BUSHING KIT	
(2) HEAVY DUTY 9/16" ID STEM BUSHING (2) HEAVY DUTY 9/16" ID STEM WASHER	(2) M12-1.25 JAM NUT
TOOLS REQUIRED	
JACK JACK STANDS DRILL 11/32" DRILL BIT CENTER PUNCH	TORQUE WRENCH 5/16" SOCKET / WRENCH 9/16" SOCKET / WRENCH 17MM SOCKET / WRENCH 19MM SOCKET / WRENCH
TECH NOTES	
<p>1. INTENDED FOR USE WITH ICON RXT LEAF SPRINGS (#158505) ONLY.</p> <p>2. YOUR ICON SHOCK ASSEMBLIES COME FACTORY CHARGED TO 150 PSI. RELEASING NITROGEN PRESSURE MAY LEAD TO SHOCK MALFUNCTION AND REDUCED RIDE QUALITY. FAILURE CAUSED BY LOW NITROGEN PRESSURE IS NOT COVERED UNDER ICON'S WARRANTY POLICY.</p> <p>3. INSTALL STEM BUSHINGS AND HARDWARE AS SHOWN IN THE DIAGRAM. FAILURE CAUSED BY INCORRECT INSTALLATION OF STEM BUSHINGS AND HARDWARE IS NOT COVERED UNDER ICON'S WARRANTY POLICY.</p>	



WARNING!
<p>** READ ALL INSTRUCTIONS THOROUGHLY FROM START TO FINISH BEFORE BEGINNING INSTALLATION! IF THESE INSTRUCTIONS ARE NOT PROPERLY FOLLOWED SEVERE FRAME, SUSPENSION AND TIRE DAMAGE MAY RESULT TO THE VEHICLE!</p> <p>** ICON VEHICLE DYNAMICS RECOMMENDS THAT YOU EXERCISE EXTREME CAUTION WHEN WORKING UNDER A VEHICLE THAT IS SUPPORTED WITH JACK STANDS.</p> <p>** ICON VEHICLE DYNAMICS RECOMMENDS ALL INSTALLATION TO BE PERFORMED BY A PROFESSIONAL SHOP/SERVICE TECHNICIAN. PRODUCT FAILURE CAUSED BY IMPROPER INSTALLATION WILL NOT BE COVERED UNDER ICON'S WARRANTY POLICY.</p>

INSTALLATION

- Using a properly rated jack, raise the rear of the vehicle and support the frame rails with jack stands. Ensure the jack stands are secure and set properly before lowering the jack. NEVER WORK UNDER AN UNSUPPORTED VEHICLE. Remove the rear wheels.
- Remove the factory shock using two 17mm socket/wrenches.
- Install the RXT shock using the factory lower bolt on the lower shock mount and the supplied bushing kit for the upper stem mount. Install stem bushings and hardware as shown in the diagram: Install the lower nut and fasten until there are enough exposed threads available to secure the upper jam nut. Install jam nut until it is flush with the top of the stem (DO NOT OVERTIGHTEN) and torque to 50 ft-lbs while holding the lower nut with a 19mm wrench. Do not overtighten bushing assembly, as this can lead to shock stem failure. Failure caused by incorrect installation of stem bushings and hardware is NOT covered under ICON's warranty policy.

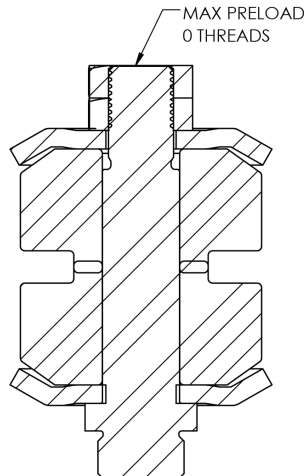

- Mount the reservoir to the reservoir bracket using the supplied hose clamps and a 5/16" nut driver. Make sure that the hose clamps line up with the machined grooves on the reservoir surface.

5. Hold the reservoir against the frame with a small amount of slack in the hose. Mark the location on the frame of the mounting hole of the reservoir bracket. [FIGURE 1]

FIG.1



6. Remove the reservoir bracket from the reservoir.

7. Center punch the hole location previously marked and then drill an 11/32" hole in the frame. Be careful not to drill through any lines or wires running inside of the frame channel.

8. Thread the holes using the supplied 3/8" self tapping bolts and a 9/16" socket.

9. Fasten the reservoir bracket to the frame using the self tapping bolts.

10. Mount the reservoir to the bracket using a 5/16" nut driver. Make sure that the hose clamps line up with the machined grooves on the reservoir surface.

11. Install the wheels and lower the vehicle back to the ground. [Torque lugs to factory spec]

VERIFY ALL FASTENERS ARE PROPERLY TORQUED BEFORE DRIVING VEHICLE.

RETORQUE ALL NUTS, BOLTS AND LUGS AFTER 100 MILES AND PERIODICALLY THEREAFTER.

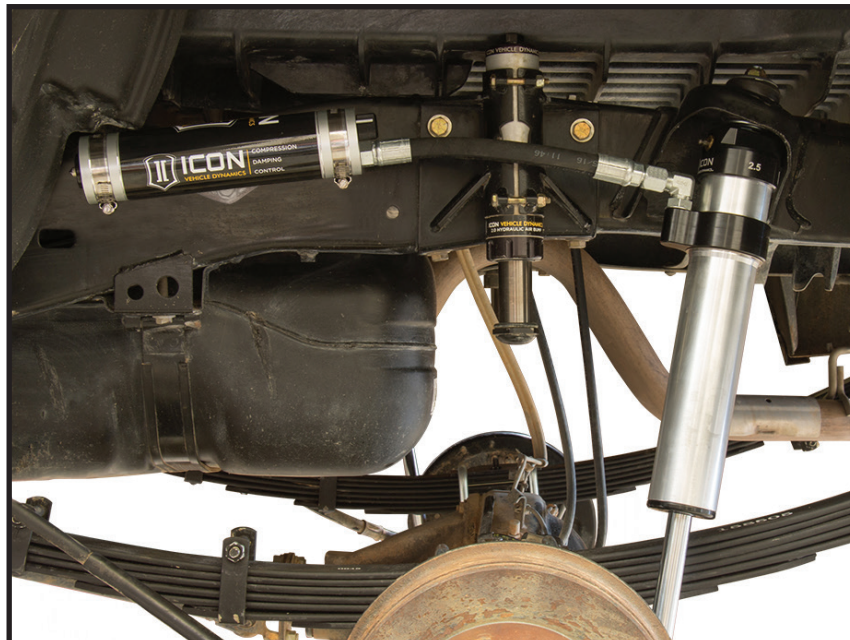

2.5 VS SERIES SHOCK & COILOVER TECHNICAL INFORMATION

MAINTENANCE

ICON shock absorbers are a high quality rebuildable race style shock absorber designed for optimal performance. With a unit of this caliber on your vehicle, routine maintenance is required to keep them looking and operating in like new condition. Residual oil and assembly lube may be present at all seal paths from the factory out of the box and is considered normal. Pooling of oil however is not acceptable at any time and one should contact the ICON dealer where purchased.

BELOW ARE GUIDELINES BASED ON HOW YOU USE YOUR VEHICLE BUT YOUR MILEAGE MAY VARY:

STREET USE:

- Send in for factory servicing every 40,000 miles or if a leak develops, ride quality decreases, or they begin to make excessive noise.
- Remove any buildup of road salt, mud, or debris from shocks and coil springs anytime accrued
- Clean with mild soap and water with each oil change or anytime you notice build up.
- Wax the cylinders yearly with automotive wax to prevent corrosion.
- Check nitrogen pressure yearly. (252004 charge needle assembly available at any ICON distributor)
- Check bearings for excessive wear yearly.
- **DO NOT** apply any type of lube to the upper and lower bearings.

STREET/DIRT:

- Send in for factory servicing every 15,000 miles or if a leak develops, ride quality decreases, or they begin to make excessive noise.
- Clean with mild soap and water with each oil change, offroad trip, or anytime you notice build up.
- Wax the cylinders yearly with automotive wax to prevent corrosion.
- Check nitrogen pressure each dirt outing. (252004 charge needle assembly available at any ICON distributor)
- Check bearings for excessive wear yearly.
- **DO NOT** apply any type of lube to the upper and lower bearings.

DIRT USE:

- Send in for factory servicing every 1,000 miles.
- Check nitrogen pressure each outing. (252004 charge needle assembly available at any ICON distributor)
- Remove any buildup of mud or debris from shocks and coil springs after every outing.

SELF-SERVICE:

- Contact ICON for service kits & tools at (951) 689-4266.

PRODUCT REGISTRATION

Please visit: <http://www.iconvehicledynamics.com/tech-support/registration/> to register your product.

ICON VEHICLE DYNAMICS SHOCK ABSORBER WARRANTY

This shock absorber has a 1 year warranty against any manufacturer's defects. If a shock fails within the initial year of ownership, the shock must be shipped to ICON Vehicle Dynamics for inspection and service. If a shock is inspected and it has been determined the shock failed due to neglect, damage caused by improper installation or any other reason besides "normal wear and tear", the owner of said shock is responsible for all service costs. This includes labor, parts, and shipping.

ICON Vehicle Dynamics warrants to the original retail purchaser who owns the vehicle on which the product was originally installed. ICON Vehicle Dynamics does not warrant the product for finish, alterations, modifications and/or installation contrary to ICON Vehicle Dynamics instructions. ICON Vehicle Dynamics products are not designed, nor are they intended to be installed on vehicles used in race applications, for racing purposes or for similar activities. (A "race" is defined as any contest between two or more vehicles, or a contest of one or more vehicles against the clock, whether or not such contest is for a prize). This warranty does not include coverage for police or taxi vehicles, race vehicles, or vehicles used for government or commercial purposes. Also excluded from this warranty are sales outside of the United States of America and Canada.

ICON Vehicle Dynamics' obligation under this warranty is limited to the repair or replacement, at ICON Vehicle Dynamics' discretion, of the defective product. Any and all costs of removal, installation or re-installation, freight charges and incidental or consequential damages are expressly excluded from this warranty. Items that are subject to wear are not considered defective when worn and are not covered.

ICON Vehicle Dynamics components must be installed as a complete kit as shown in our current application guide. Any substitutions or exemptions of required components will immediately void the warranty. Some finish damage may happen to parts during shipping and is not covered under warranty.

This warranty is expressly in lieu of all other warranties expressed or implied. This warranty shall not apply to any product that has been improperly installed, modified or customized subject to accident, negligence, abuse or misuse.

To send a shock in for warranty please visit our website <http://www.iconvehicledynamics.com/tech-support/shock-service/>

ICON VEHICLE DYNAMICS

PERFORMANCE SUSPENSION SYSTEMS AND SHOCK ABSORBERS

7929 Lincoln Ave. Riverside, CA 92504 Phone: 951.689.ICON Fax: 951.689.1016
www.iconvehicledynamics.com



FOLLOW US ON FACEBOOK!



7929 Lincoln Ave. Riverside, CA 92504
Phone: 951.689.ICON | Fax: 951.689.1016

PART #	DESCRIPTION
158505	05-UP TACOMA MULTI-RATE RXT LEAF SPRING

COMPONENTS INCLUDED	
(1) 158505 05+ TACOMA RXT LEAF PACK W/ADD IN LEAF	
HARDWARE INCLUDED	
N/A	
TOOLS REQUIRED	
JACK JACK STANDS LOCKING PLIERS TORQUE WRENCH	9/16" SOCKET / WRENCH 7/8" SOCKET / WRENCH 17MM SOCKET / WRENCH 19MM SOCKET / WRENCH
TECH NOTES	
<p>THE ICON RXT LEAF SPRING IS MODULAR, MEANING THAT YOU CAN CONFIGURE THE SPRING PACK TO YOUR DESIRED SETTING FROM THESE AVAILABLE OPTIONS:</p> <p>OPTION #1 - THE SPRING IS SHIPPED AT THIS SETTING (LIGHTEST SPRING RATE).</p> <p>OPTION #2 - REPLACE THE 3RD SPRING (COUNTING FROM THE TOP DOWN) WITH THE ADDITIONAL LEAF.</p> <p>OPTION #3 - PLACE THE ADDITIONAL LEAF BETWEEN THE 2ND AND 3RD SPRING (COUNTING FROM THE TOP DOWN). DO NOT REMOVE LEAF FROM SPRING PACK.</p> <p>ICON'S MEASURED SPECS FROM OUR TEST TRUCK (2016 4WD DCLB TACOMA):</p> <p>OPTION #1 - LIFT HEIGHT OVER STOCK: + 1.875" (UNLOADED)</p> <p>OPTION #2 - LIFT HEIGHT OVER STOCK + 2.25" (UNLOADED) LIFT HEIGHT OVER STOCK WITH 200LBS IN BED: + 1.75"</p> <p>OPTION #3 - LIFT HEIGHT OVER STOCK: + 2.625" (UNLOADED) LIFT HEIGHT OVER STOCK WITH 600LBS IN BED: + 1.125" LIFT HEIGHT OVER STOCK WITH 1200LBS IN BED: - .125"</p>	

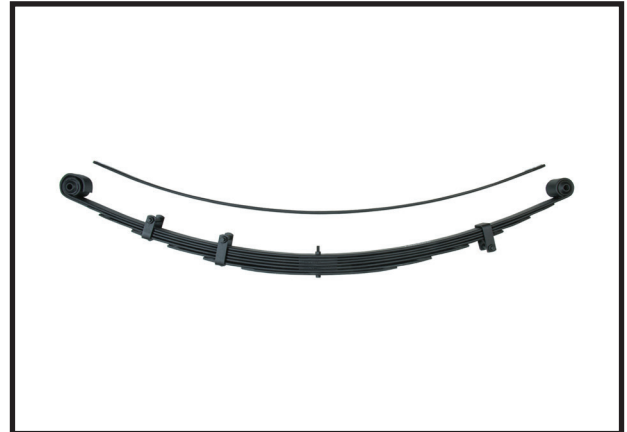

WARNING!
<p>** READ ALL INSTRUCTIONS THOROUGHLY FROM START TO FINISH BEFORE BEGINNING INSTALLATION! IF THESE INSTRUCTIONS ARE NOT PROPERLY FOLLOWED SEVERE FRAME, SUSPENSION AND TIRE DAMAGE MAY RESULT TO THE VEHICLE!</p> <p>** ICON VEHICLE DYNAMICS RECOMMENDS THAT YOU EXERCISE EXTREME CAUTION WHEN WORKING UNDER A VEHICLE THAT IS SUPPORTED WITH JACK STANDS.</p> <p>** ICON VEHICLE DYNAMICS RECOMMENDS ALL INSTALLATION TO BE PERFORMED BY A PROFESSIONAL SHOP/SERVICE TECHNICIAN. PRODUCT FAILURE CAUSED BY IMPROPER INSTALLATION WILL NOT BE COVERED UNDER ICON'S WARRANTY POLICY.</p>

INSTALLATION

- Using a properly rated jack, raise the rear of the vehicle and support the frame rails with jack stands. Ensure the jack stands are secure and set properly before lowering the jack. NEVER WORK UNDER AN UNSUPPORTED VEHICLE. Remove the rear wheels.
- Remove the lower shock bolt using (2) 17mm. [FIGURE 1]

FIG.1

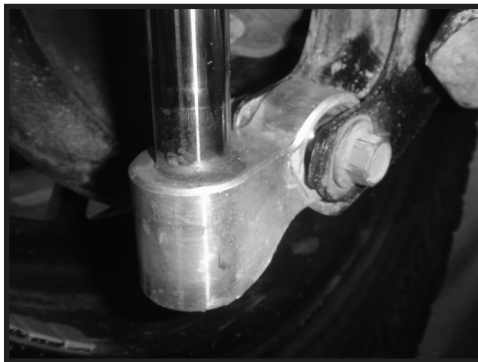
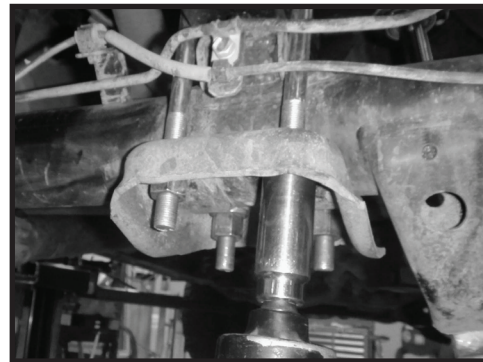

FIG.2



- Support the axle using a floor jack. Remove the U-bolts from 1 side of the truck using a 19mm. [FIGURE 2]
- Slowly lower the axle, being careful to not overextend brake or ABS lines.

5. Remove the bolt from the front frame pocket using a 19mm. [FIGURE 3]

FIG.3



FIG.4

6. Remove the upper and lower nut from the spring shackle using a 19mm. [FIGURE 4]

7. Remove bolt connecting the shackle to the frame.

8. Lift the shackle and leaf pack out of the pocket of the frame.

9. Lift the factory spring and shackle out, being careful to not damage brake lines, hoses, and ABS lines. 2 people are recommended as the leaf springs are heavy.

IF ADJUSTING THE RXT SPRING CONFIGURATION:

A. Remove the front clip bolts and rear clip using a 17mm. [FIGURE A]

FIG.A

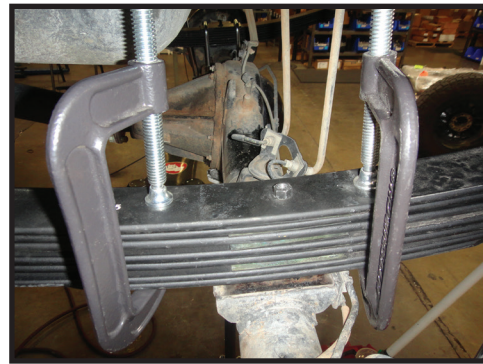

FIG.B

B. Clamp the pack on both sides of the center pin. [FIGURE B]

C. Use locking pliers to hold the head of the center pin and remove the nut using a 9/16".

D. Carefully release the clamps from the spring pack. Use caution as the spring may still be under tension.

E. Remove the top 2 springs of the pack. [FIGURE C]

FIG.C



F. Configure the spring pack as desired from the available options (refer to tech notes).

OPTION #1 - THE SPRING IS SHIPPED AT THIS SETTING (LIGHTEST SPRING RATE).

OPTION #2 - REPLACE THE 3RD SPRING (COUNTING FROM THE TOP DOWN) WITH THE ADDITIONAL LEAF. ENSURE THAT THE LONGER SIDE OF THE LEAF IS ORIENTED TOWARDS THE FRONT OF THE VEHICLE.

OPTION #3 - PLACE THE ADD-A-LEAF BETWEEN THE 2ND AND 3RD SPRING (COUNTING FROM THE TOP DOWN). DO NOT REMOVE LEAF FROM SPRING PACK. ENSURE THAT THE LONGER SIDE OF THE LEAF IS ORIENTED TOWARDS THE FRONT OF THE VEHICLE.

G. Ensure that there is a liner installed between each leaf.

H. With the top 2 leafs in place, slide the center pin through the pack and clamp together using clamps on both sides of the center pin. After the center pin is placed through the whole pack, install the nut using a 9/16". [Torque to 15 ft-lbs]

I. Install the appropriate clips for the configuration. Longer clips are provided for additional pack thickness. Tighten on half turn past snug using a 17mm.

10. Before lifting the RXT spring pack into place, loosely install the shackle on the spring with the factory bolt and nut. Ensure that the bolt is facing away from the fuel tank. The head of the bolt should be closest to the frame and the nut furthest away, failure to mount in this orientation will cause fuel tank gouging.

11. Loosely install the spring and shackle into the frame pockets using the factory hardware. Lift the axle to guide the center pin into the locating hole in the spring pad on the axle housing.

12. Place the factory bump stop (or ICON striker plate) on top of the spring.

13. Install the U-bolts and tighten (do not torque to spec yet).

14. Install shocks and wheels then lower the vehicle on the ground. [Torque to factory spec]

15. Torque leaf spring pivot bolts to factory spec using a 19mm.

16. Torque lower shock bolts to factory spec using a 17mm.

17. Torque U-bolts to 90 ft-lbs using a 7/8".

18. Check parking brake cable for clearance on the spring clip. If it is making contact with the spring clip, bend the bracket on the front spring pocket. [FIGURE 5 & 6]

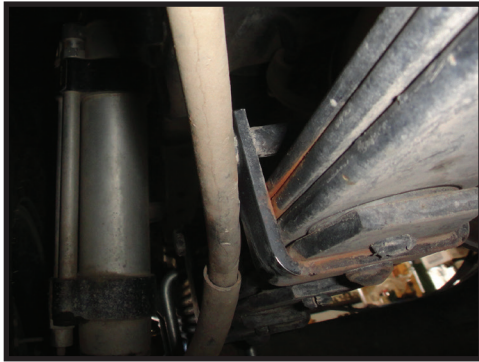

FIG.5



FIG.6

NOTE: If the metal sleeve on the parking brake cable comes into contact with the shock as the suspension compresses, carefully remove (cut) sleeve from the parking brake cable. [FIGURE 7]



FIG.7

VERIFY ALL FASTENERS ARE PROPERLY TORQUED BEFORE DRIVING VEHICLE.

RETORQUE ALL NUTS, BOLTS AND LUGS AFTER 100 MILES AND PERIODICALLY THEREAFTER.



2005-UP TOYOTA TACOMA RXT MULTI-RATE LEAF SPRING

OPTION 1

AS SHIPPED

INSTALL SPRING IN ORIGINAL CONFIGURATION, LEAVING ADDITIONAL LEAF OUT

LIFT HEIGHT OVER STOCK:
1.875"
(UNLOADED)



OPTION 2

LEAF REPLACEMENT

REPLACE THE 3RD SPRING IN THE PACK WITH THE ADDITIONAL LEAF PROVIDED IN KIT

LIFT HEIGHT OVER STOCK:
2.25"
(UNLOADED)

1.75"
(200LB LOAD)



OPTION 3

LEAF ADDITION

ADD THE ADDITIONAL LEAF PROVIDED TO THE PACK, IN BETWEEN THE 2ND AND 3RD SPRING

LIFT HEIGHT OVER STOCK:
2.625"
(UNLOADED)

1.125"
(600LB LOAD)



ICON VEHICLE DYNAMICS LIMITED LIFETIME WARRANTY

ICON Vehicle Dynamics warrants to the original retail purchaser who owns the vehicle on which the product was originally installed. ICON Vehicle Dynamics does not warrant the product for finish, alterations, modifications and/or installation contrary to ICON Vehicle Dynamics instructions. ICON Vehicle Dynamics products are not designed, nor are they intended to be installed on vehicles used in race applications, for racing purposes or for similar activities. (A "race" is defined as any contest between two or more vehicles, or a contest of one or more vehicles against the clock, whether or not such contest is for a prize). This warranty does not include coverage for police or taxi vehicles, race vehicles, or vehicles used for government or commercial purposes. Also excluded from this warranty are sales outside of the United States of America and Canada.

ICON Vehicle Dynamics' obligation under this warranty is limited to the repair or replacement, at ICON Vehicle Dynamics' discretion, of the defective product. Any and all costs of removal, installation or re-installation, freight charges and incidental or consequential damages are expressly excluded from this warranty. Items that are subject to wear are not considered defective when worn and are not covered.

ICON Vehicle Dynamics components must be installed as a complete kit as shown in our current application guide. Any substitutions or exemptions of required components will immediately void the warranty. Some finish damage may happen to parts during shipping and is not covered under warranty.

This warranty is expressly in lieu of all other warranties expressed or implied. This warranty shall not apply to any product that has been improperly installed, modified or customized subject to accident, negligence, abuse or misuse.

ICON VEHICLE DYNAMICS LIABILITY DISCLAIMER

ICON does not make any representations or warranties regarding the fitness of any ICON product for a particular installation or conformance of any ICON product with a particular vehicle application. Installation of any ICON suspension system is at the sole discretion of the end user and in making a purchase of any ICON suspension system, the purchaser assumes the responsibility and liability for any and all damage or injury, of any kind or nature whatsoever, caused by, resulting from, arising out of, or occurring in connection with the use or installation of any ICON suspension system. ICON is not liable for and specifically disavows any installation that is not in conformance with original equipment manufacturer's recommendations or instructions. Purchaser agrees that in the event of any claim or lawsuit arising out of the installation or use of an ICON suspension system, purchaser shall indemnify and hold harmless ICON, its agents, employees, officers and owners from and against any and all loss, expense, damage or injury that ICON may sustain as the result of such claim. [If applicable, ICON defers to and recommends recalibration of any/all vehicle stability systems after suspension installation.]



ICON VEHICLE DYNAMICS®
PERFORMANCE SUSPENSION SYSTEMS AND SHOCK ABSORBERS

7929 Lincoln Ave. Riverside, CA 92504 Phone: 951.689.ICON Fax: 951.689.1016
www.iconvehicledynamics.com



FOLLOW US ON FACEBOOK!

