









## **INSTALLATION MANUAL**

**Lightweight Low Profile Tri-Fold Hard Tonneau Cover**

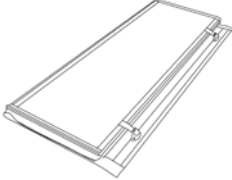
**(#47&#48) 2016-2023 Tacoma**

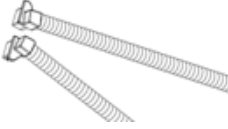
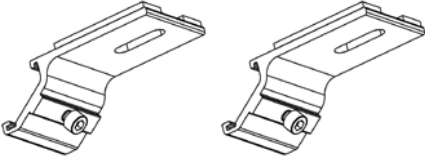
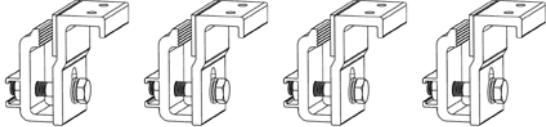
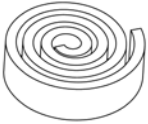

**When you open the tonneau cover box you will see the parts:**

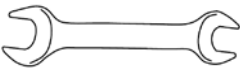
Item	Description	Qty	Picture
1-A	Tonneau Cover	1	
1-B	Left Side Rail	1	
1-C	Right Side Rail	1	
1-D	Front Bolt	2	
1-E	Drain Tube	2	
1-F	Front Support Plate (Including Bolts)	2	
1-G	Clamp Assembly	4	
1-H	Foam Seal Tape	1	
1-I	Allen Wrench	1	
1-J	#17 Wrench	1	

**STEPS:**

1. Check contents of carton with the list above.
2. Stick the foam seal tape on the front edge of the bed.

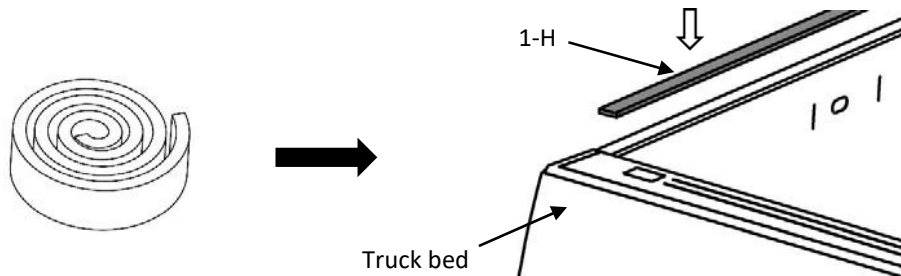

3. Slide the Front Support Plate (1-F) into the side rails, and move the Front Support Plate (1-F) to front of side

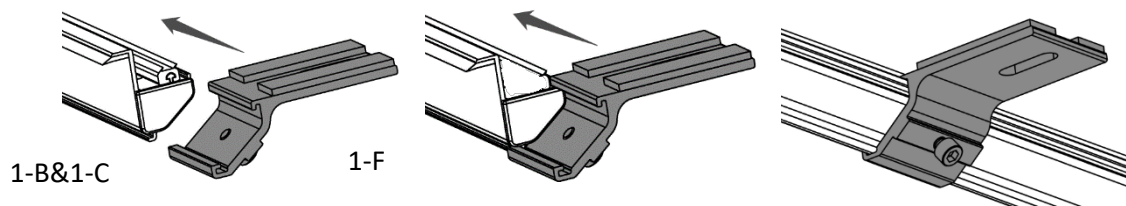

4. Insert the drain tubes (1-E) into the front of side rails.

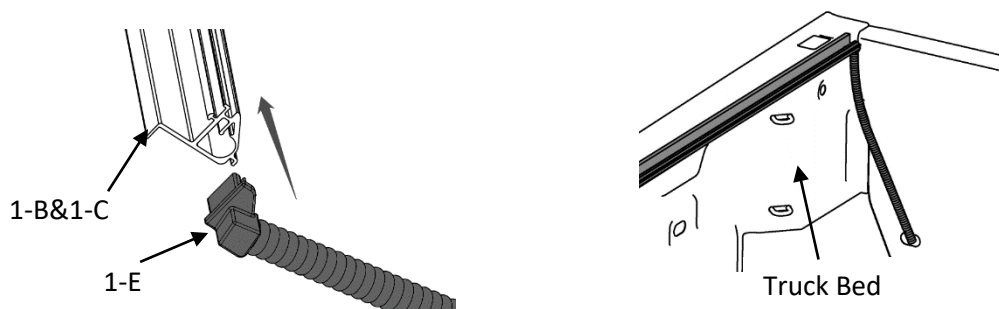

5. Unscrew and remove the aluminum block from the side rail. Insert the block into the truck bed Factory Track.

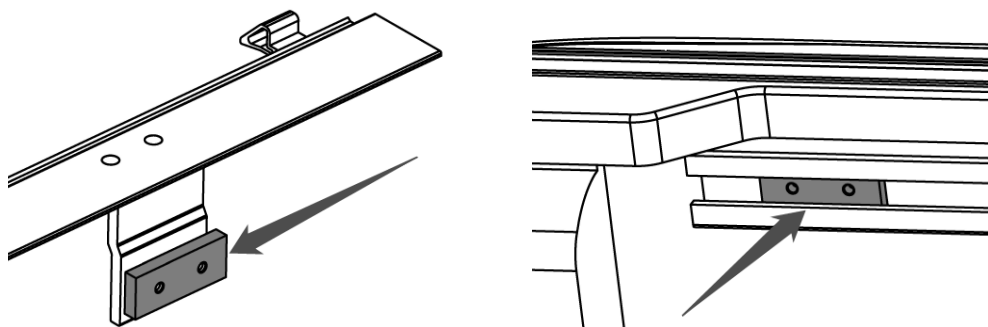

- Place the side rail on the bed rail, and push it to the front wall of truck bed. Then bolt the side rail with the aluminum block (already in the Factory Track in Step 5) together. Tighten the clamps each side.

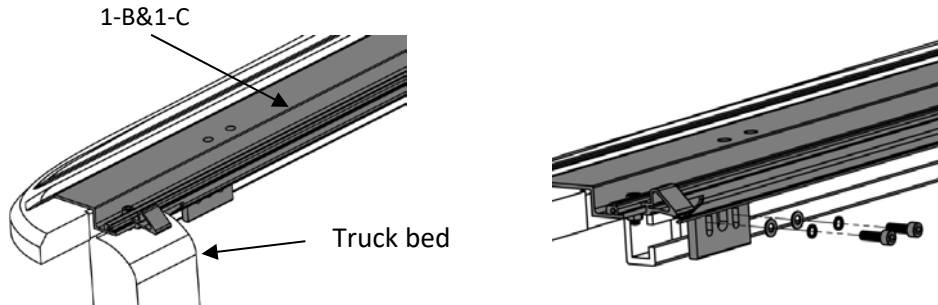

- Place the tonneau cover over on the front end of truck bed. Ensure the cover is even on all sides and sit firmly on side rails.

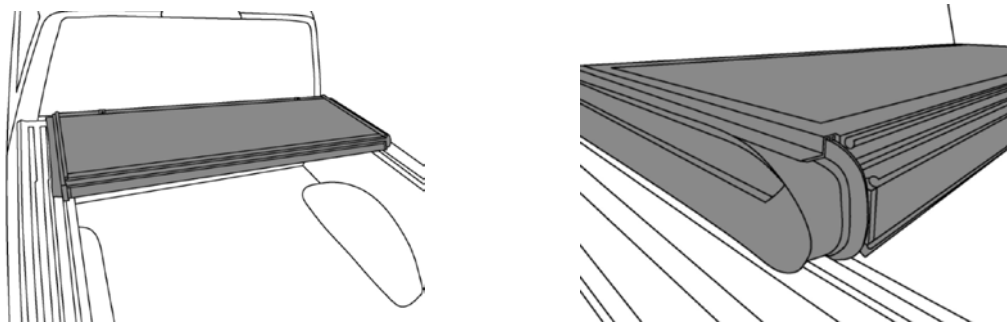

- Adjust the front support plate(1-F) to correct position, insert the front bolt into the holes on the cover front panel and front support plate. Then tighten the plastic nut under the front support plate.

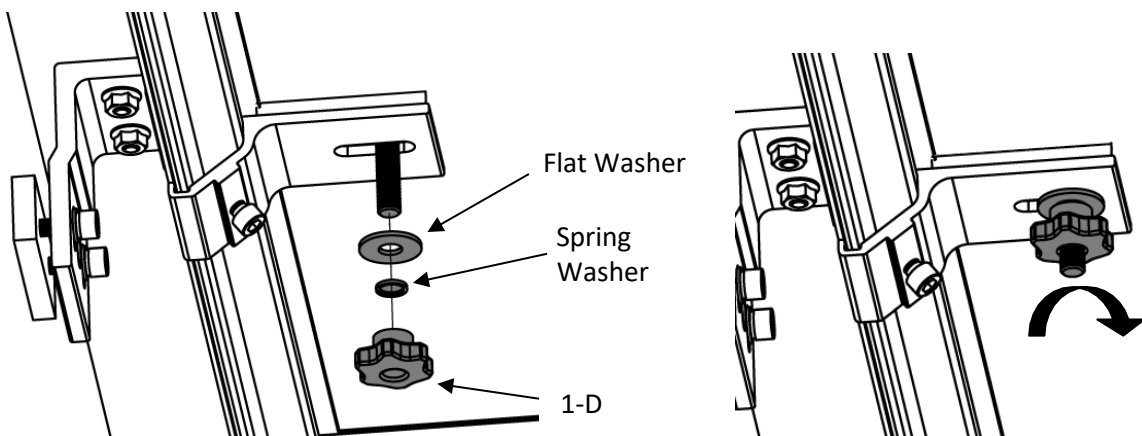
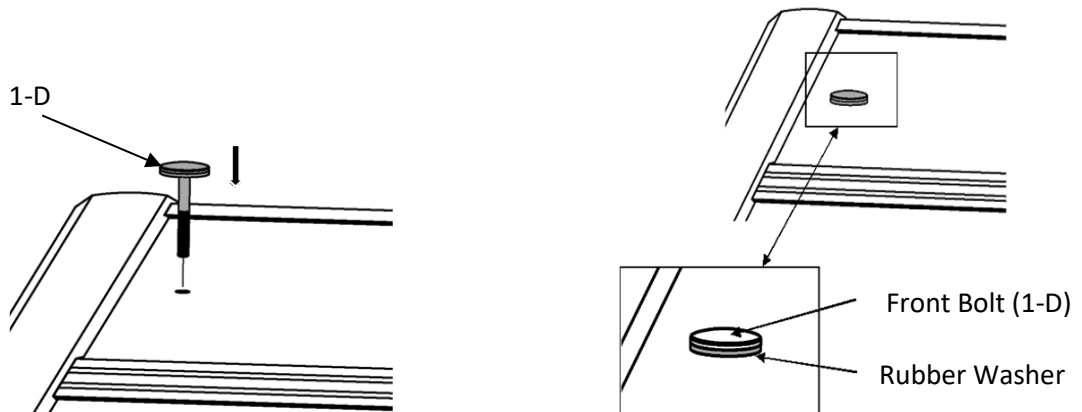

※ATTENTION: Make sure the Flat Washer and Spring Washer are all placed on bolt before screw the plastic nut on.

9. Unfold the cover, ensure the cover latch touch the side rail locking tongues. If necessary, adjust the Locking Tongue match the Latch position. Tighten the side rail locking tongues. Lock the cover and close the tailgate.

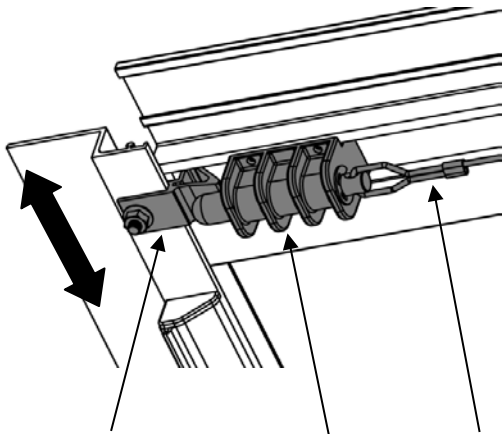
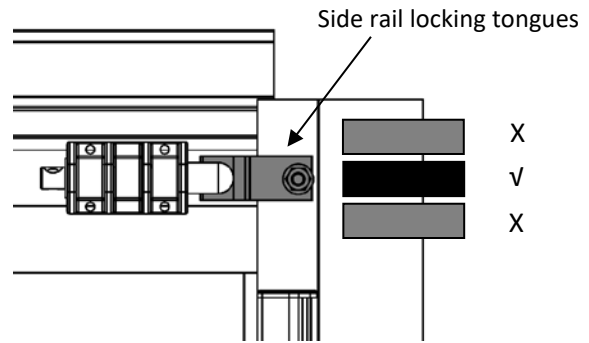
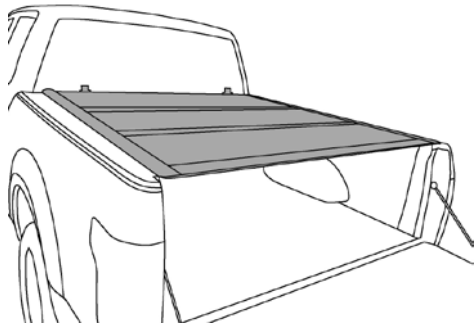

Side rail locking tongues      Latch      Lock Cable

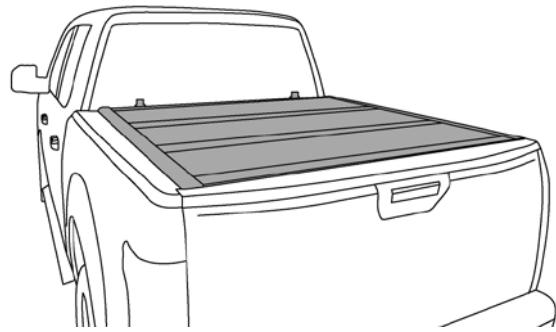

**BE ATTENTION: TIGHTEN ALL BOLTS & NUTS BEFORE DRIVING!**

## For Truck without Factory Track System:

Step 4 and 5 above are changed to the following steps:

Step-1 Remove the Clamp Assembly from the Side Rail (1-B&1-C).

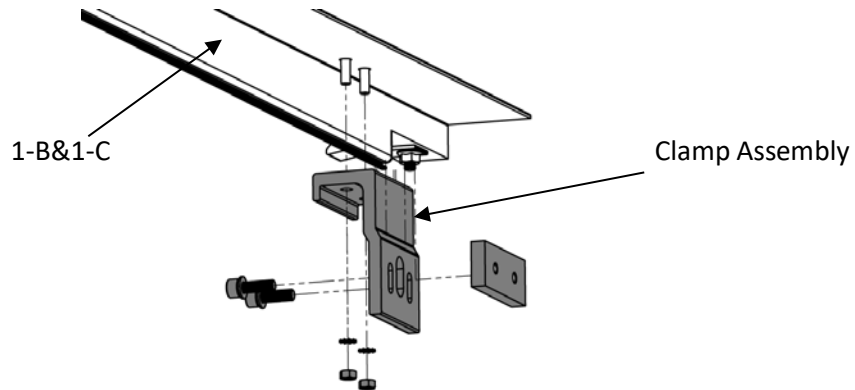

Step-2 Attach and Install the other set of Clamp Assembly (1-G) to the Side Rail (1-B&1-C), then tighten the nuts.

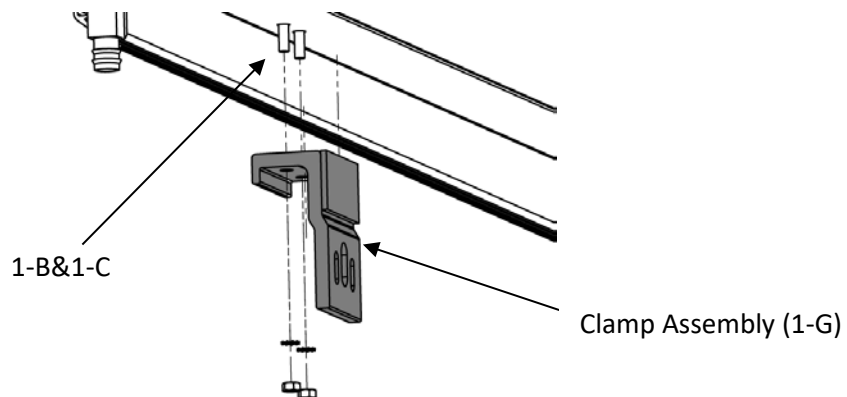

Step-3 Place the side rail on the bed rail, and push it to the front wall of truck bed. Place one clamp at the front of the side rail and one at the rear (please make sure the rear clamps is placed on the position that is closest to tailgate). Tighten the clamps each side.

