

PARTS LIST:

1	LD2 Front Bumper	4	8mm x 25 mm Button Head Bolts
1	Driver/left Bumper Fill Panel	8	8-1.25mm x 25mm Hex Bolts
1	Passenger/right Bumper Fill Panel	2	8-1.25mm x 16mm Hex Bolts
1	Driver/left side Frame Bracket	14	8mm x 24mm x 2mm STD Flat Washers
1	Passenger/right side Frame Bracket	12	8mm x 16mm x 1.6mm STD Flat Washers
1	Driver/left side LED "L" Bracket	8	8mm Lock Washers
1	Passenger/right side LED "L" Bracket	6	8-1.25mm Hex Nuts
1	Driver/left side Top Light Bracket	6	8-1.25mm Nylon Lock Nuts
1	Passenger/right side Top Light Bracket	14	6-1.0mm x 20mm Button Head Combo Bolts
1	Long Center Fill Panel	2	6-1.0mm x 20mm Button Head Bolts
2	Small Inner Fill Panels	4	6mm x 15mm x 1mm Flat Washers
2	Small Outer Fill Panels	2	6mm Nylon Lock Nuts
2	Plastic License Plugs	14	6mm Flange Hex Nuts
1	License Plate Bracket	1	5mm Wrench
6	10-1.50mm x 40mm Hex Bolts	1	4mm Wrench
12	10mm x 24mm x 2mm Large Flat Washers	1	Edge Trim (cut to fit)
6	10mm Lock Washers		
6	10-1.5mm Hex Nuts		

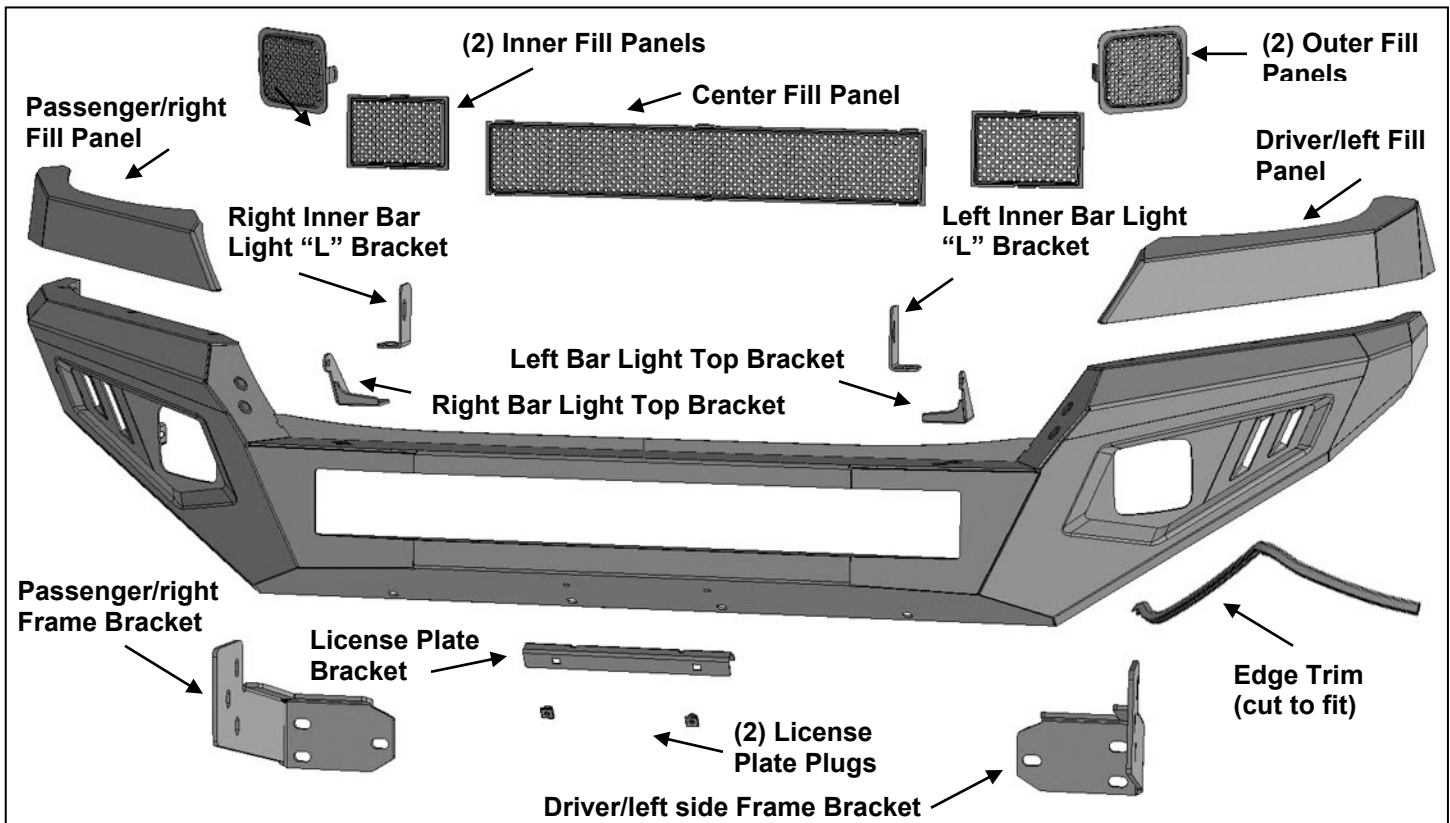

PROCEDURE:

REMOVE CONTENTS FROM BOX. VERIFY ALL PARTS ARE PRESENT. READ INSTRUCTIONS CAREFULLY BEFORE STARTING INSTALLATION. BUMPER IS HEAVY, ASSISTANCE IS HIGHLY RECOMMENDED TO AVOID POSSIBLE INJURY OR DAMAGE TO THE VEHICLE. CUTTING IS REQUIRED.

1. Remove the license plate and bracket. Open the hood and remove the plastic cover from the top of the radiator and grille, **(Figure 1)**. Next, carefully remove the plastic grille, **(Figure 2)**. Remove the air dam from the bottom of the bumper.

2. On models with factory fog lights, unplug the wiring harness leading to the front bumper. Move harness away from bumper.
3. Carefully pull the front leading end of the fender flares to release from the bumper cover, **(Figure 3)**. The flares do not need to be fully removed, simply release the front portion and leave the rest of the flare attached.
4. Remove the hardware attaching the plastic bumper cover at the top, ends and bottom. With assistance, pop the ends off of the inner clip and pull the bumper off and away from the vehicle. Remove the plastic bumper mount from below the passenger/right side headlight, **(Figure 3)**. Reinstall the factory hardware to secure the headlight to the vehicle. Repeat this Step to remove the plastic mount from the driver/left side of the vehicle.
5. Remove the plastic impact pads from the aluminum inner bumper, **(Figure 4)**. Next, remove the cross bar, plastic splash guards from both ends and both aluminum bumper brackets from the ends of the frame, **(Figure 5)**.
6. Select the passenger/right Frame Mounting Bracket, **(Figure 6)**. Reuse the factory hex nuts to attach the Bracket to the end of the frame, **(Figures 6 & 7)**. Repeat this Step to install the driver/left Bracket.
7. Carefully unwrap the Bumper assembly. Select the passenger/right Bumper Upper Fill Panel, **(Figure 8)**. Attach the Fill Panel to the top of the Bumper with (3) 8mm x 20mm Hex Bolts, (6) 8mm Flat Washers and (3) 8mm Nylon Lock Nuts. Line up the edges of the Fill Panel with the Bumper and full tighten the hardware. Cover the edge of the Fill Panel and part of the Bumper with the included Edge Trim, **(Figure 9)**. Repeat this Step to install the driver/left Fill Panel and Edge Trim.
8. Determine if accessory lights, (not included), or Screen Fill Panels will be installed at this time.

IMPORTANT: It may be easier to install Center Fill Panels and/or lights before installing Bumper.

Screen Fill Panel Installation (do not install fill panels if installing lights).

- a. Select desired Screen Fill Panels. **NOTE:** Outer Panels are square with rounded corners, Inner panels are rectangular with sharp corners, **(Figure 10)**.
- b. Attach Screen Fill Panels as needed with the included 6mm Button Head Combo Bolts and 6mm Flange Nuts, **(Figure 10)**. Fully tighten Fill Panel hardware at this time. Repeat to install all Panels as desired.

Inner center LED bar style light installation (light not included).

- a. Select the driver/left "L" Light Bar Bracket, **(Figure 11)**. **NOTE:** "L" Brackets are offset to adjust for different widths of LED Bar Lights and can be installed on either side as needed.
- b. Attach the L Bracket to the slot on the back of the Bumper with (1) 8mm x 25mm Hex Bolt, (2) 8mm Flat Washers, (1) 8mm Lock Washer and (1) 8mm Hex Nut, **(Figures 11 & 12)**. Repeat this Step to install the remaining "L" Bracket on the other side of the Bumper. **IMPORTANT:** The Bumper features slots designed for 20" and 30" bar style lights. Attach the Brackets to the correct slots in the Bumper. If necessary, hold the light up to the slots to help determine correct slots to use and combination of Brackets.
- c. Attach the light to the "L" Brackets with the hardware included with the light or the supplied (2) 8mm x 16mm Hex Bolts, (2) 8mm Lock Washers and (2) 8mm Flat Washers or (2) 6mm x 16mm Hex Bolts, (2) 6mm Lock Washers and (2) 6mm Flat Washers, **(Figures 11 & 12)**. Do not fully tighten hardware at this time.

Top mounted 30" bar style LED light (not included).

- a. Remove the (2) rubber plugs from the driver/left side mounting holes, **(Figure 13)**.
- b. Select the driver/left Light Bracket. Attach the Bracket to the top of the Bumper with (2) 8mm x 25mm Button Head Bolts, (4) 8mm Flat Washers, (2) 8mm Lock Washers and (2) 8mm Hex Nuts, **(Figure 13)**. Do not tighten hardware at this time.
- c. Repeat previous Steps to attach the passenger/right Bracket.
- d. Select the 30" light, (not included). Attach light to Top Brackets with the hardware included with the light. Adjust the width of the Brackets to the light and fully tighten bracket hardware.

IMPORTANT: Top Light Brackets are designed to install 30" bar style LED lights with outside length dimensions of 31.653" (804mm) to 32.44" (824mm) only, **(Figure 14)**. Fully tighten top light hardware once adjusted.

Outer LED cube style light installation (light not included).

- a. Attach lights to mounting tabs on back of each end of the Bumper, **(Figure 13)**.

9. With assistance, position the Bumper Assembly up to the inside of the Frame Brackets. Temporarily support the weight of the Bumper. **WARNING:** To avoid possible injury or damage to the vehicle, do not proceed until the bumper is fully and safely supported. Attach the Bumper to the passenger/right Bracket with the included (3) 10mm x 40mm Hex Bolts, (6) 10mm Flat Washers, (3) 10mm Lock Washers and (3) 10mm Hex Nuts, **(Figures 15 & 16)**. Leave hardware loose at this time. Repeat this Step to attach the driver/left side of the Bumper to the Bracket.
10. Level and adjust the bumper and fully tighten all hardware.
11. Cover the passenger/right plastic fender flare with removable tape, (masking tape for example). Hold the fender flare in position on the fender and over the end of the Bumper. Draw a straight line onto the tape to match where the end of the fender and Bumper meet, **(Figure 17)**. Use a sharp knife or hacksaw blade to carefully cut the leading end off of the flare along the line. Reattach the fender flare to the fender. Repeat to cut the driver/left fender flare.
12. If front license plate is required, attach the License Plate Bracket to the holes in the bumper with the included (2) 6mm x 20mm Button Head Screws, (4) 6mm Flat Washers and (2) 6mm Nylon Lock Nuts, **(Figure 18)**. Insert (2) Plastic Plugs into the square holes in the Bracket. Reuse the factory screws to attach the license plate to the plastic plugs.
13. Reinstall the plastic grille and top cover if previously removed, **(Figure 4)**.
14. Do periodic inspections to the installation to make sure that all hardware is secure and tight.

To protect your investment, Do not use any type of polish or wax that may contain abrasives that could damage the finish. Mild soap may be used to clean the Front Bumper assembly.

Passenger/right Side Installation Pictured

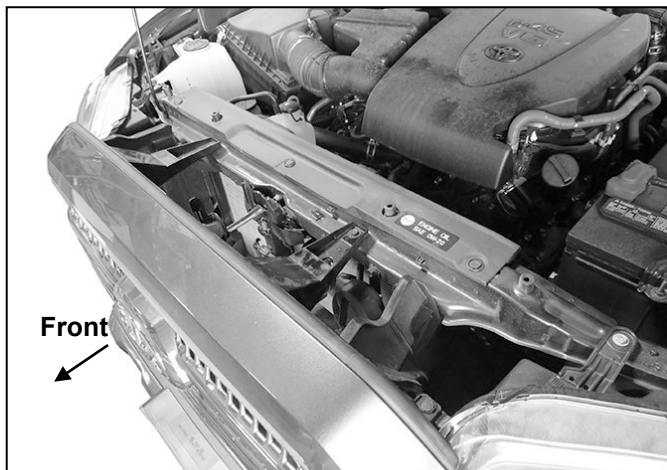

(Fig 1) Remove plastic cover from top of radiator



(Fig 2) Remove grille, air dam from below bumper and license plate. Remove plastic bumper cover

Passenger/right Side Installation Pictured



(Fig 3) Remove plastic block (arrow) from front edge of fender. Reinstall hardware to secure headlight



(Fig 4) Remove plastic impact bumper and aluminum crossbar from bumper brackets

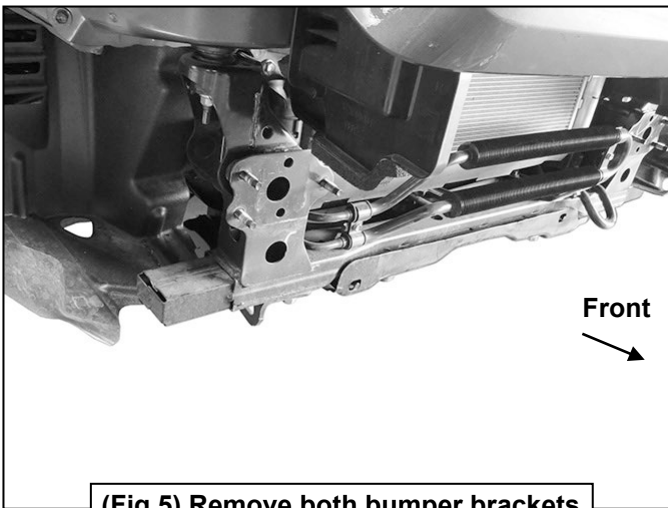

(Fig 5) Remove both bumper brackets

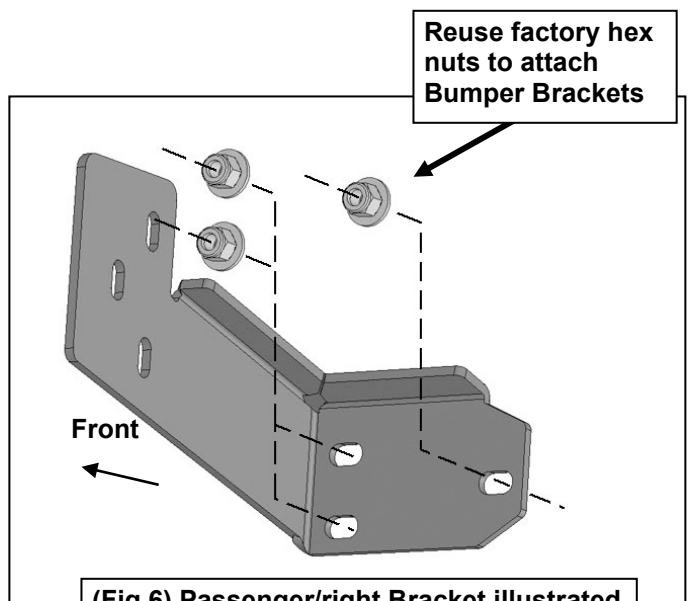

(Fig 6) Passenger/right Bracket illustrated

Passenger/right Side Installation Pictured

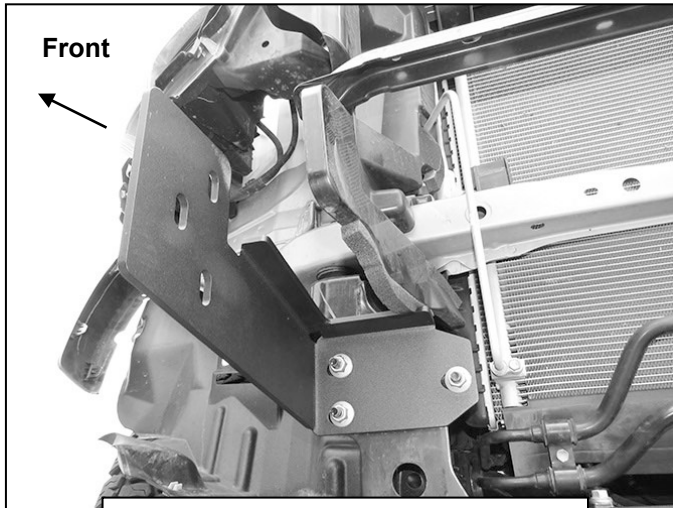

(Fig 7) Passenger/right side Frame Bracket attached to frame

- (3) 8mm x 25mm Hex Bolts
- (6) 8mm Flat Washers
- (3) 8mm Nylon Lock Nuts

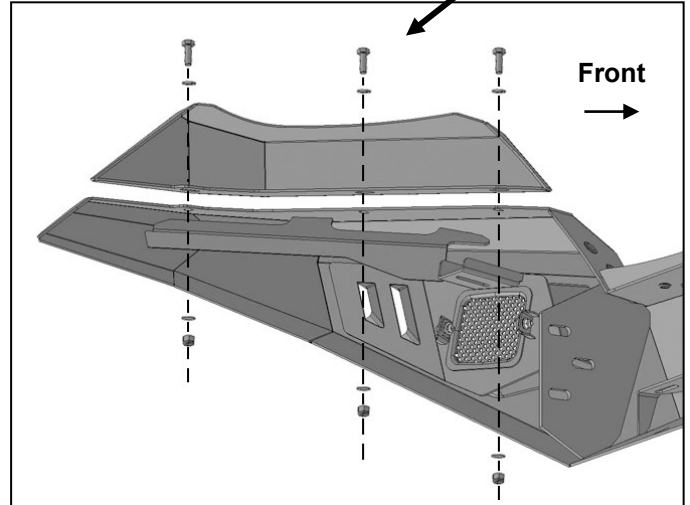

(Fig 8) Attach Fill Panel to top of Bumper

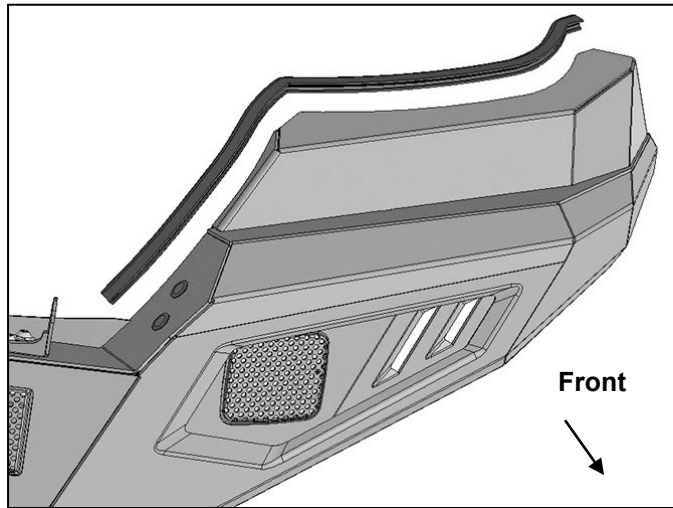

(Fig 9) Attach included Edge Trim to top of Fill Panel and Bumper if desired (note must cut to fit)

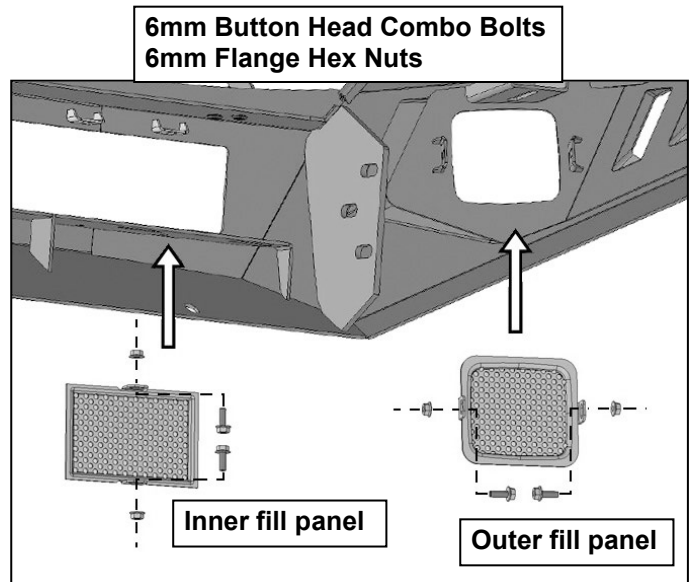

(Fig 10) Attach Mesh Fill Panels as desired to fill unused openings for lights (lights not included)

Passenger/right Side Installation Pictured

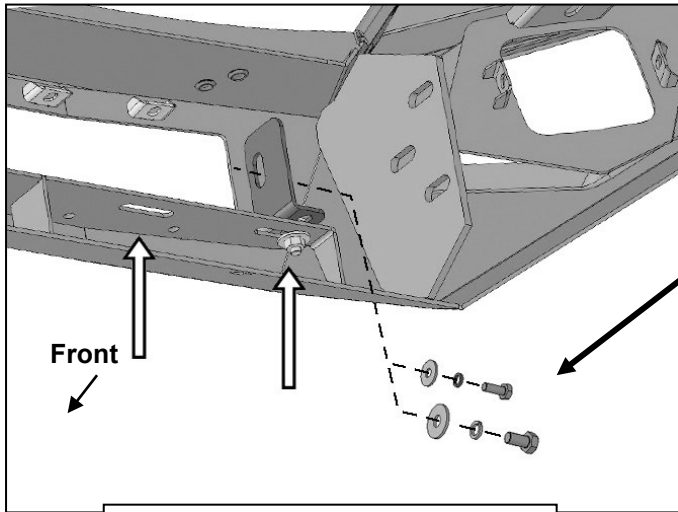

(Fig 11) Note multiple slots for different widths of lights (arrows)

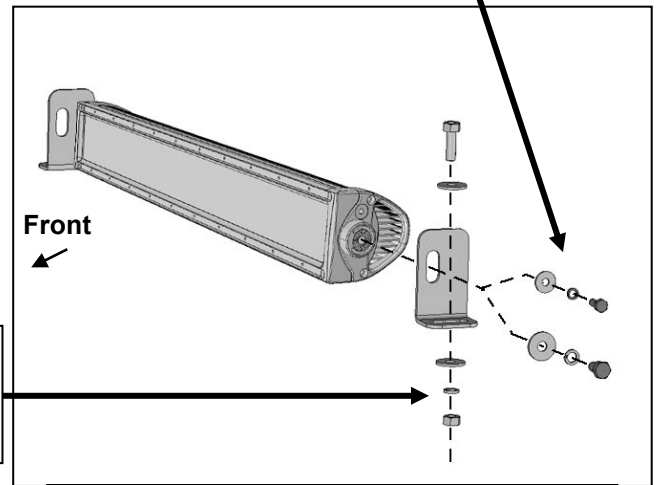

(Fig 12) Bracket illustration is a suggestion only. Brackets are offset to allow adjustment for all widths of lights

- (2) 8mm x 25mm Button Head Bolts
- (4) 8mm Flat Washers
- (2) 8mm Lock Washers
- (2) 8mm Hex Nuts

- 8mm x 25mm Hex Bolt
- (2) 8mm Flat Washers
- 8mm Lock Washer
- 8mm Hex Nut

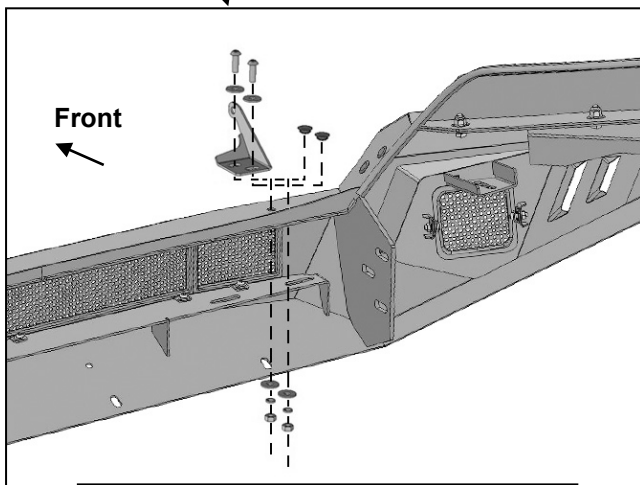

(Fig 13) Remove rubber plugs to attach Top Light Bracket to Bumper

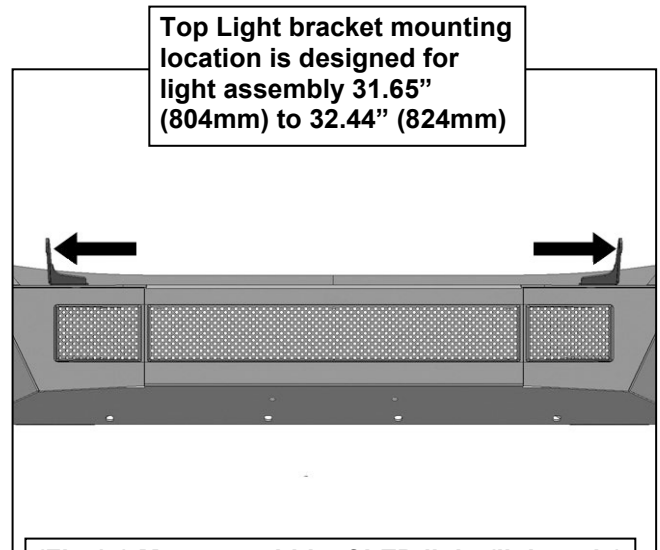

(Fig 14) Measure width of LED light (light only) before installation of Top Light Brackets

Passenger/right Side Installation Pictured

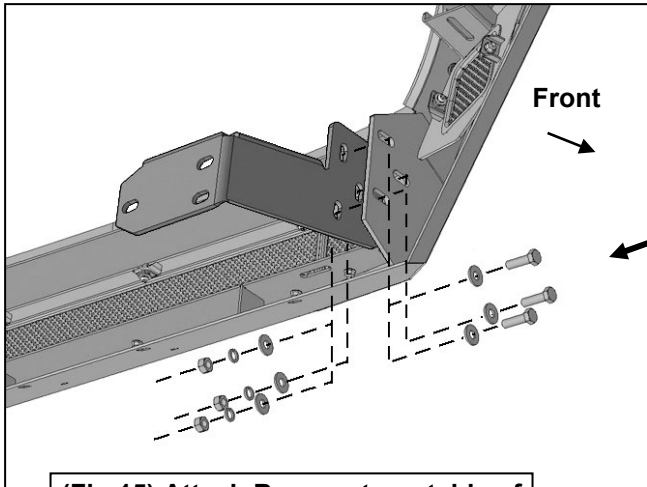

(Fig 15) Attach Bumper to outside of Passenger/right side Frame Bracket

WARNING! Do not crawl under bumper unless the bumper is properly supported on blocks or stands or the bumper may fall.

- (3) 10mm x 35mm Hex Bolts
- (6) 10mm Flat Washers
- (3) 10mm Lock Washers
- (3) 10mm Hex Nuts

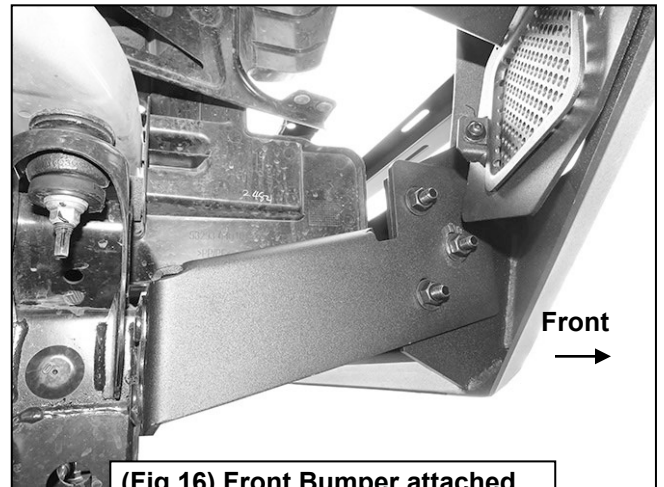

(Fig 16) Front Bumper attached to Passenger side Frame Bracket



(Fig 17) Cut fender flare to match end of Bumper

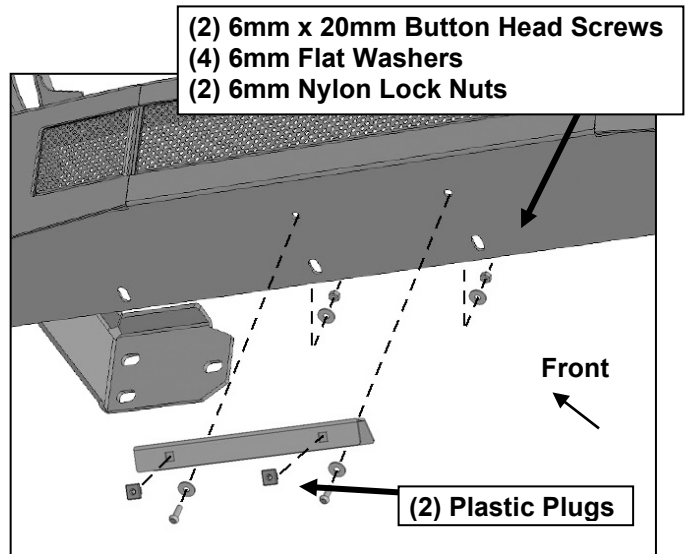

- (2) 6mm x 20mm Button Head Screws
- (4) 6mm Flat Washers
- (2) 6mm Nylon Lock Nuts

(2) Plastic Plugs

(Fig 18) Attach License Plate Bracket to Front Bumper



Complete Installation

