

HARDWARE DESCRIPTION		QTY.
HWKT-03054X		
FLBW-00894X	M8-1.25 X 30MM CLASS 8.8 FLANGE CAP SCREW W/WASHER	12

PARTS INCLUDED	QTY
DRIVER SIDE	1
PASSENGER SIDE	1

Step 1: Locate the driver side step rail.

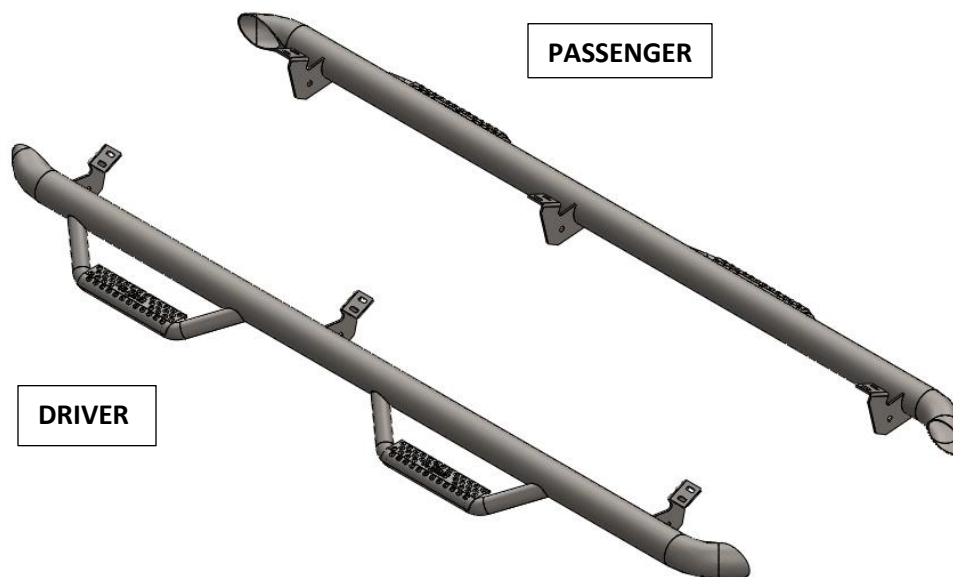

Step 2 Remove any factory hardware and discard.

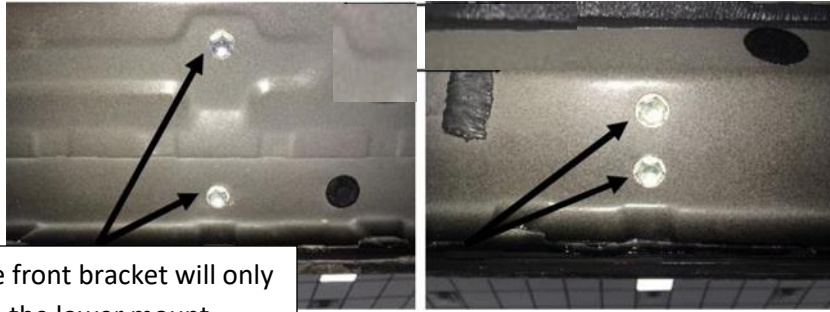

The front bracket will only use the lower mount

Step 3: Starting with the driver side, position step up to the body of the vehicle and align the brackets up with the factory mounting locations.

Step 4: Beginning with the center bracket, start one of the M8x30mm hex bolts into the factory bolt location and leave loose. Start the second M8x30mm hex bolt in the same bracket and loosely tighten.

Step 5: Start all remaining M8x30mm hex bolts in each bracket and leave loose.

Step 6: After final positioning, start at the rear of the vehicle and tighten the lower portion of the bracket to 15-20 ft/lbs of torque. Continue this until all of the lower fasteners have been tightened, then move to the top bolt and repeat the process.

Step 7: Repeat steps 2-6 for driver side.