

# **INSTALLATION INSTRUCTIONS**

**CS-1 LD FRONT BUMPER**

**2012-2015 TACOMA**

**TT13413/TT13414**

**PARTS LIST:**

1	CS-1 "LD" Front Bumper	2	12mm x 44mm x 4mm Large Spacer Washers
1	Center Mesh Fill Panel	2	12mm x 32mm x 3mm Flat Washers
1	Driver/left Mesh Fill Panel	2	12mm Nylon Lock Nuts
1	Passenger/right Mesh Fill Panel	6	10-1.5mm x 30mm Hex Bolts
1	Driver/left Cutting Template	6	10mm x 20mm x 2mm Flat Washers
1	Passenger/right Cutting Template	6	10mm Lock Washers
1	Driver/left Frame Mounting Bracket	6	8-1.25mm x 25mm Hex Bolts
1	Passenger/right Frame Mounting Bracket	2	8-1.25mm x 16mm Hex Bolts
1	Driver/left "L" Top Light Bracket	14	8mm x 24mm x 2mm Flat Washers
1	Passenger/right "L" Top Light Bracket	8	8mm Lock Washer
2	Inner "L" Brackets for mesh or light	6	8mm Hex Nut
2	Plastic Plugs for License Plate	10	6mm x 20mm Button Head Combo Bolts
1	2000mm Edge Trim	2	6mm Flange Nuts
2	Rectangular Spacers for Frame Brackets	1	4mm Wrench
2	12-1.75mm x 120mm Hex Bolts	10	Nylon Wire Ties

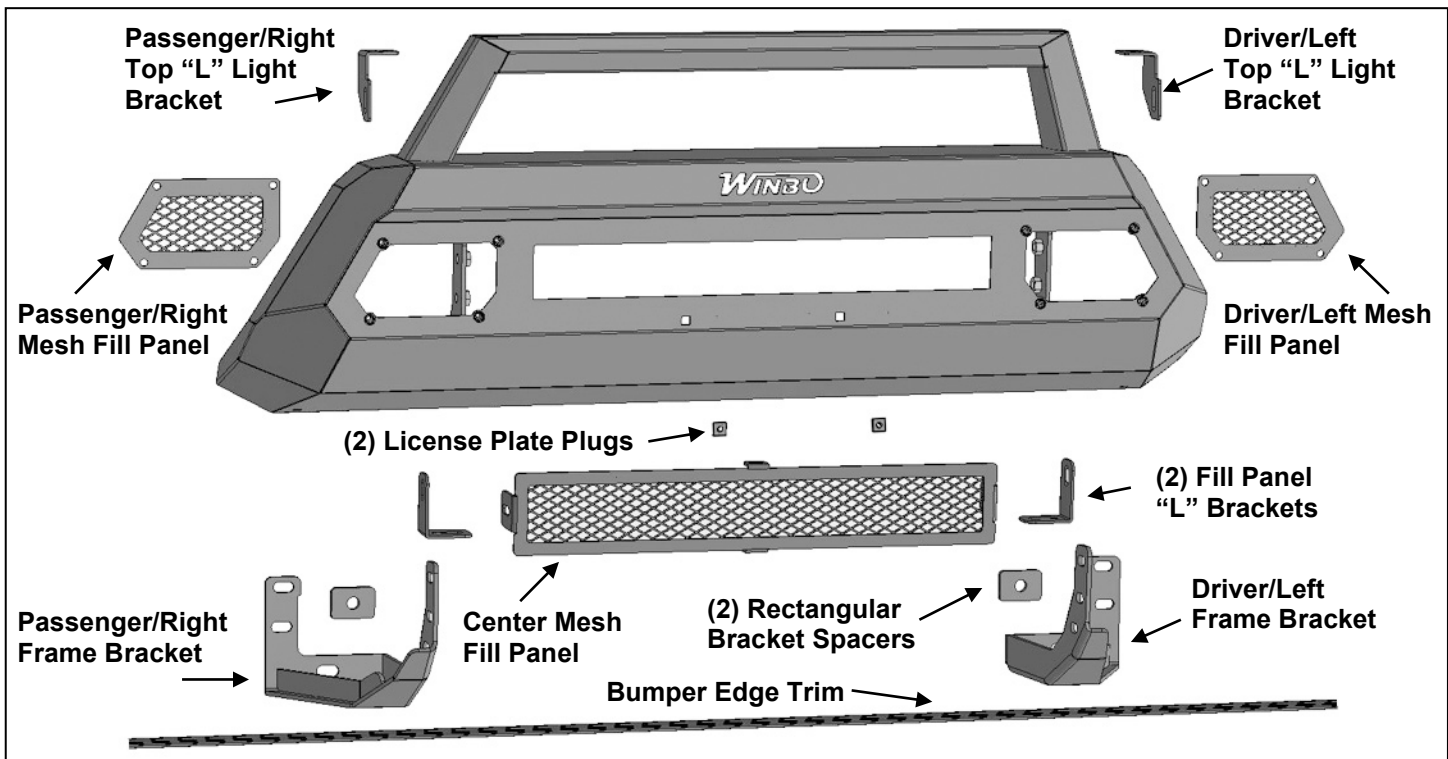

**PROCEDURE:**

**REMOVE CONTENTS FROM BOX. VERIFY ALL PARTS ARE PRESENT. READ INSTRUCTIONS CAREFULLY BEFORE STARTING INSTALLATION. ASSISTANCE IS HIGHLY RECOMMENDED TO AVOID POSSIBLE INJURY OR DAMAGE TO THE VEHICLE. CUTTING IS REQUIRED.**

1. Remove the license plate and bracket from the bumper cover.
2. Move to the driver/left wheel opening. Remove the hardware attaching the plastic bumper cover to the bottom of the front fender and inner fender liner, **(Figure 1)**. On models with factory fog lights, unplug both lights and release the wiring harnesses from the clips attached to the back of the bumper and move wiring harnesses away from the bumper. Continue to remove the hardware attaching the bottom and passenger/right end of the bumper cover, **(Figures 1 & 2)**.
3. With assistance, remove the bumper cover, **(Figure 3)**. **NOTE:** Depending on model year, it may be necessary to temporarily remove the grille and plastic fill panels below the head lights to access cover hardware. Move cover to a clean surface.
4. Remove the (2) outer hex nuts attaching the driver/left impact bumper bracket to the frame, **(Figure 3)**.

5. Select the driver/left Frame Bracket, **(Figure 4)**. Reuse the (2) factory hex nuts to attach the Bracket over the impact bumper bracket, **(Figures 4 & 6)**. Leave hardware loose at this time.
6. Insert (1) 12mm x 120mm Hex Bolt with (1) 12mm x 44mm Spacer Washer through the back of the frame crossmember. Slide (1) Rectangular Spacer between the Bracket and the front of the crossmember, **(Figure 5)**. Guide the long Hex Bolt through the Spacer and Bumper Bracket. Secure the Bracket to the long Hex Bolt with (1) 12mm x 32mm STD Flat washer and (1) 12mm Nylon Lock Nut, **(Figures 5 & 6)**. Snug but do not fully tighten Bumper Bracket hardware at this time.
7. Repeat **Steps 5 & 6** to install the passenger/right Frame Bracket.
8. Determine if accessory lights, (not included), or Screen Fill Panels will be installed at this time.

**IMPORTANT:** It may be easier to install Center Fill Panels and/or lights before installing Bumper.

**Inner Screen Fill Panel Installation (do not install Center Fill Panel if installing light).**

- a. Select (1) "L" Light Bar Bracket, **(Figure 7)**.
- b. Attach the "L" Bracket to the slot on the back of the driver/left side of the Bumper with (1) 8mm x 25mm Hex Bolt, (2) 8mm Flat Washers, (1) 8mm Lock Washer and (1) 8mm Hex Nut, **(Figure 7)**. Repeat this Step to attach the "L" Bracket to the passenger/right side of the Bumper.
- c. Select the center Screen Fill Panel, **(Figure 8)**.
- d. Attach the Screen to the "L" Brackets with the included (2) 8mm x 25mm Hex Bolts, (4) 8mm Flat Washers, (2) 8mm Lock Washers and (2) 8mm Hex Nuts, **(Figure 8)**. Do not fully tighten hardware at this time.
- e. Attach the center of the Screen Fill Panel to the top and bottom of the opening in the Bumper with the included (2) 6mm Button Head Combo Bolts and (2) 6mm Flange Nuts, **(Figure 8)**. Push the Screen up against the back of the Bumper and fully tighten Fill Panel hardware only.

**Inner center LED bar style light installation (20" light not included-do not install Mesh Panel with light).**

- a. Select (1) "L" Light Bar Bracket, **(Figure 7)**.
- b. Attach the "L" Bracket to the slot on the back of the driver/left side of the Bumper with (1) 8mm x 25mm Hex Bolt, (2) 8mm Flat Washers, (1) 8mm Lock Washer and (1) 8mm Hex Nut, **(Figure 7)**. Repeat this Step to attach the "L" Bracket to the passenger/right side of the Bumper.
- c. Attach the light to the "L" Brackets with the hardware included with the light or the supplied (2) 8mm x 16mm Hex Bolts, (2) 8mm Lock Washers and (2) 8mm Flat Washers, **(Figure 9)**. Adjust and fully tighten light and "L" bracket hardware only at this time.

**Top mounted 20" bar style LED light (not included).**

- a. Select the driver/left Top Light Bracket. Attach the Bracket to the slot on the back of the Bumper Hoop with (1) 8mm x 25mm Hex Bolt, (2) 8mm Flat Washers, (1) 8mm Lock Washer and (1) 8mm Hex Nut, **(Figure 10)**. Do not tighten hardware at this time.
  - b. Repeat previous Step to attach the passenger/right Bracket.
  - d. Select the 20" light, (not included). Attach the light to the Top Light Brackets with the hardware included with the light or the supplied (2) 8mm x 16mm Hex Bolts, (2) 8mm Lock Washers and (2) 8mm Flat Washers, **(Figure 10)**. Adjust and fully tighten light and Bracket hardware only.
9. Move to the factory plastic bumper cover. Remove the decorative cover from the center of the bumper cover, **(Figure 11)**. Use removable tape, (masking tape for example), to cover the pockets in the bumper cover. Select the driver/left Cutting Template. Use the template to mark the area to cut from the pocket, **(Figure 12)**. Use a sharp knife or hacksaw blade to cut out the pocket to clear the Bumper Bracket. Repeat this Step to cut the passenger/right side of the bumper cover, **(Figure 13)**.
10. Models with inner LED Bar Style Light (light not included).
- a. Apply removable tape to top of bumper cover.
  - b. Locate center of bumper cover. Measure and mark a vertical line outward from center line 10-1/2" (270mm) to each side, **(Figure 12)**.
  - c. Mark a horizontal line 2-3/4" (70mm) down from top, **(Figure 12)**.
  - d. Use a sharp knife or hacksaw blade to cut out a rectangular section from the top of the bumper cover, **(Figure 13)**.
11. Reinstall the plastic bumper cover after cutting.
12. Apply the Edge Trim to the Bumper to protect the plastic bumper cover. With assistance, position the Bumper Assembly up to the outside of the Frame Brackets. Temporarily support the weight of the

Bumper. **WARNING:** To avoid possible injury or damage to the vehicle, do not proceed until the Bumper is fully and safely supported.

13. Line up the driver/left side mounting plate on the back of the Bumper with the Frame Bracket. Attach the Bumper to the Bracket with the included (3) 10mm x 30mm Hex Bolts, (3) 10mm Lock Washers and (3) 10mm Flat Washers, (**Figures 14 & 15**). Do not fully tighten hardware at this time. Repeat this Step to attach the passenger/right side of Bumper.
14. Level and adjust the bumper and fully tighten all hardware. **IMPORTANT:** Check fit between inner light, (if installed), and cut plastic bumper cover. Remove CS-1 Bumper and trim cover for proper fit if necessary, before fully tightening hardware. Once properly adjusted and trimmed, tighten hardware.
15. Attach the Mesh Fill Panels to the Bumper with the included (8) 6mm Combo Bolts, (**Figure 16**).
16. Use the included (2) push-in Plastic Plugs to attach the front license plate, (if required), to the (2) holes in the front of the Bumper, (**Figure 17**).
17. Do periodic inspections to the installation to make sure that all hardware is secure and tight.

**To protect your investment,** Do not use any type of polish or wax that may contain abrasives that could damage the finish. Mild soap may be used to clean the Front Bumper assembly.

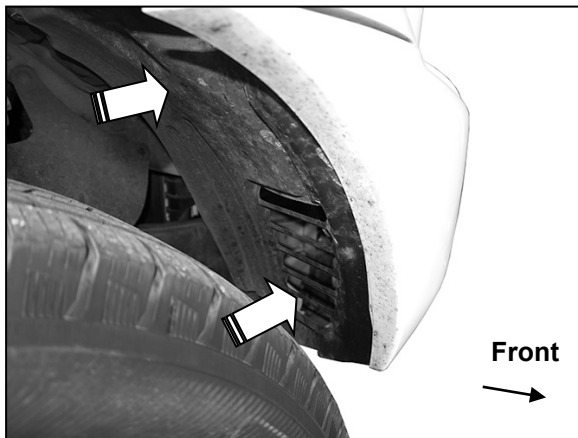

(Fig 1) Remove hardware attaching ends of bumper cover

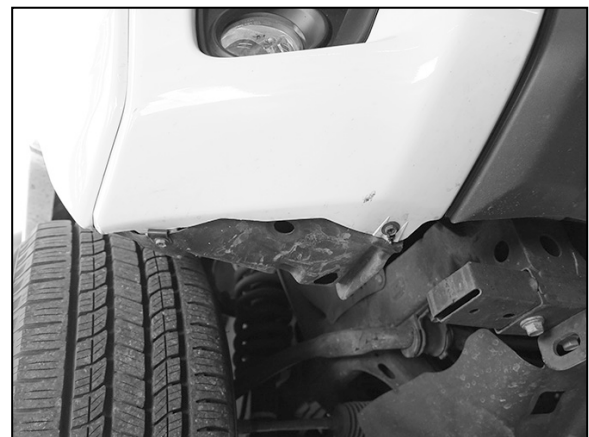

(Fig 2) Remove hardware attaching bottom of bumper cover

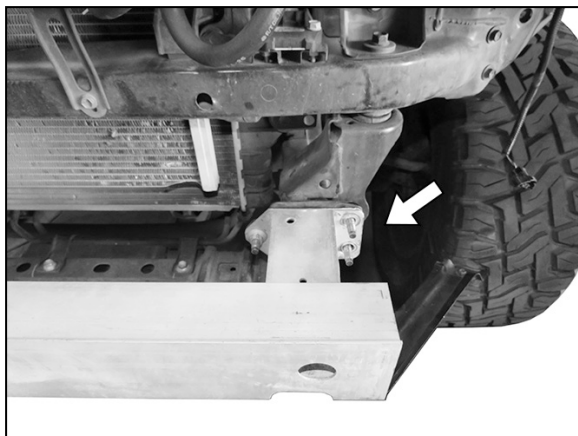

(Fig 3) Remove (2) outer hex nuts from bracket

**Driver/left Side Installation Pictured**

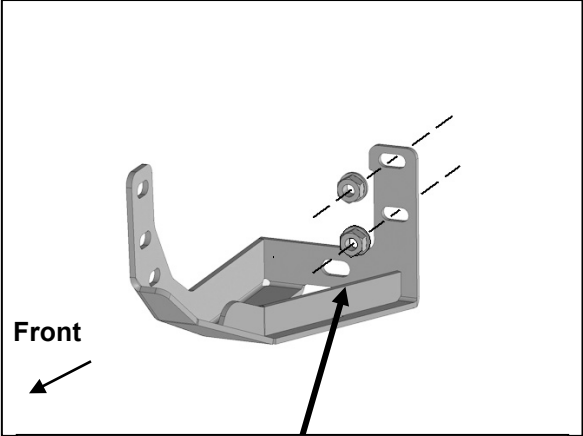

**(Fig 4) Reuse the (2) factory hex nuts to attach driver/left Frame Mounting Bracket to the inner impact bumper bracket**

**12mm x 32mm STD Flat Washer  
12mm Nylon Lock Nut**

**12mm x 120mm Hex Bolt  
12mm x 44mm Large Spacer Washer**

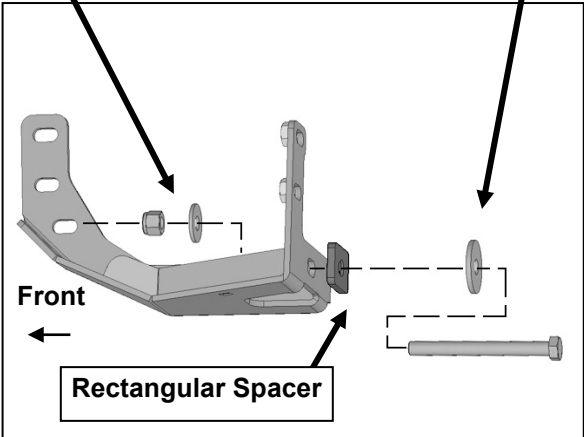

**(Fig 5) Insert Rectangular Spacer between Bracket and frame crossmember**

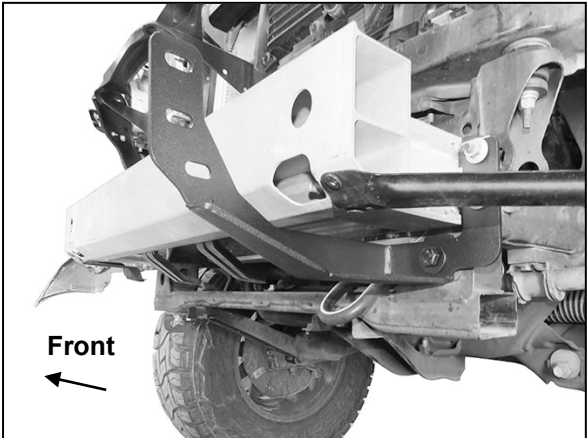

**(Fig 6) Driver/left Frame Bracket installed**

**8mm x 25mm Hex Bolt  
(2) 8mm Flat Washers  
8mm Lock Washer  
8mm Hex Nut**

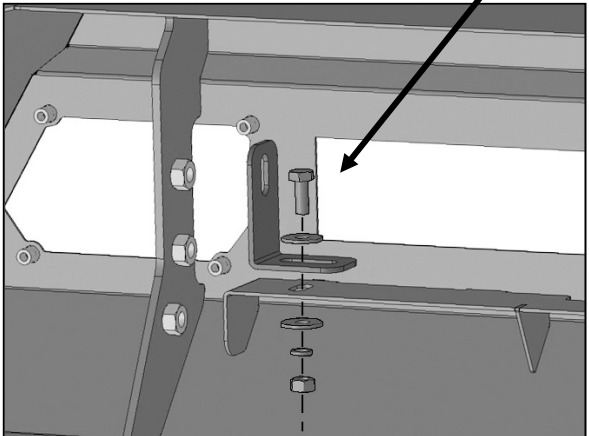

**(Fig 7) Attach inner "L" Bracket for Mesh Panel or inner bar style LED light installation (optional). Driver/left side illustrated**

**Driver/left Side Installation Pictured**

8mm x 25mm Hex Bolt  
(2) 8mm Flat Washers  
8mm Lock Washer  
8mm Hex Nut

(2) 6mm Combo Bolts  
(2) 6mm Flange Nuts

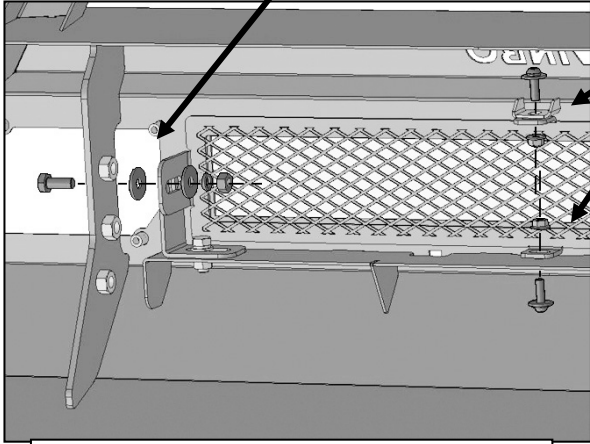

**(Fig 8) Attach Mesh Fill Panel to "L" Brackets and tabs on back of Bumper**

8mm x 16mm Hex Bolt  
8mm Lock Washer  
8mm Flat Washer

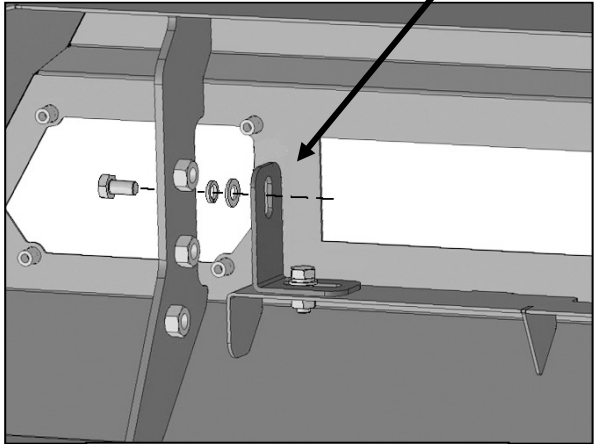

**(Fig 9) Example bar style LED light to "L" Brackets (optional)**

8mm x 16mm Hex Bolt  
8mm Lock Washer  
8mm Flat Washer

8mm x 25mm Hex Bolt  
(2) 8mm Flat Washers  
8mm Lock Washer  
8mm Hex Nut

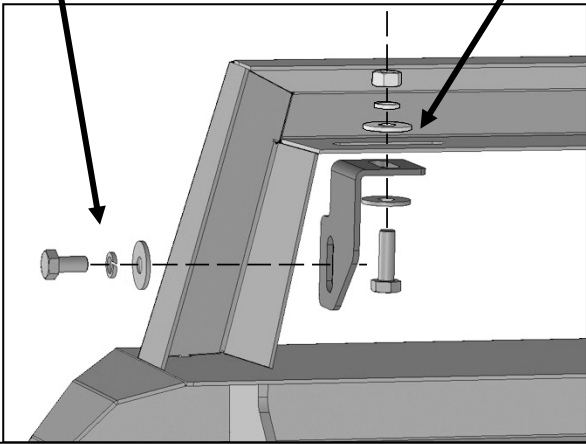

**(Fig 10) Driver/left Top Light Bracket installed**

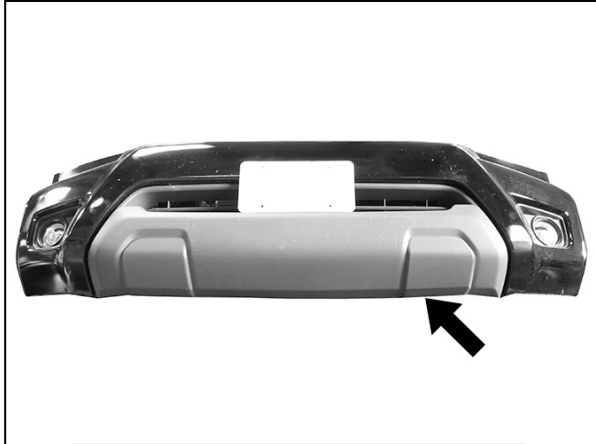

**(Fig 11) Remove the outer plastic cover from bumper cover (arrow)**

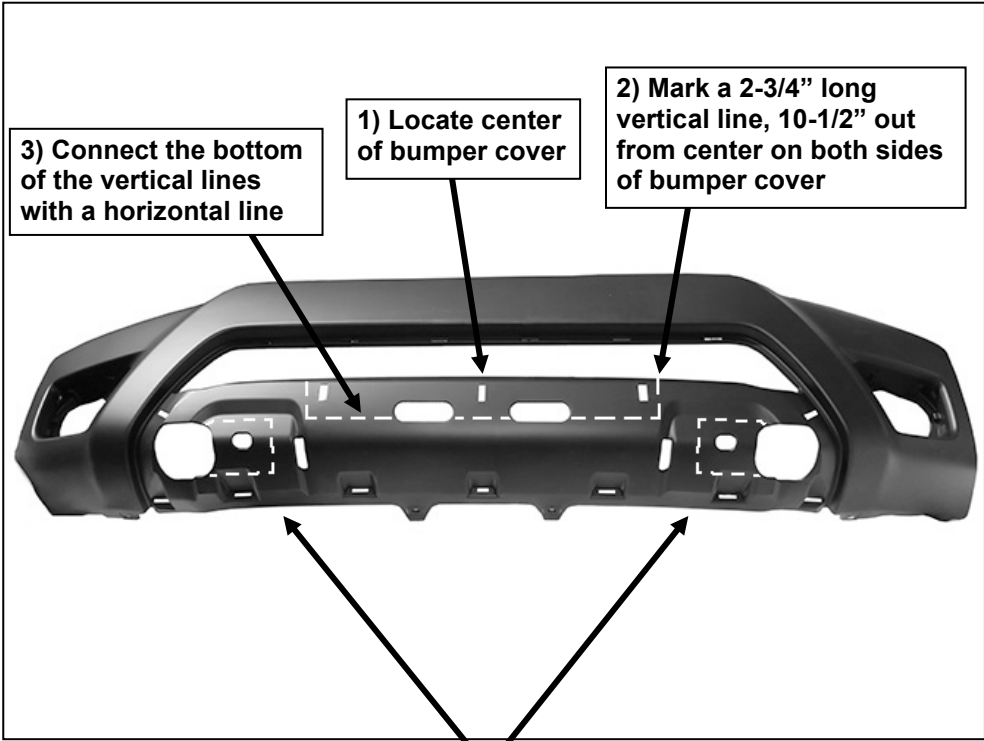

(Fig 12) Trace outline of the included Cutting Templates onto lower pockets in bumper cover. NOTE: Cutting top rectangular section only required to clear inner LED bar style light if desired

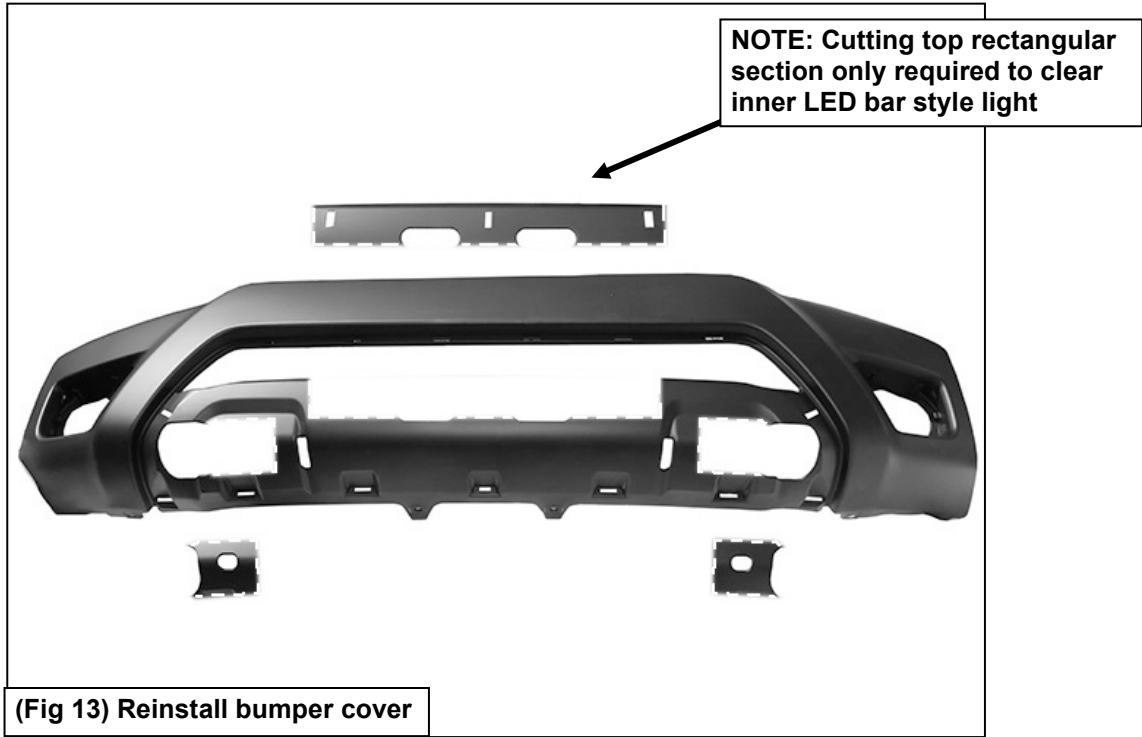

(Fig 13) Reinstall bumper cover

**WARNING!** Do not crawl under bumper unless it is properly supported on blocks or stands or the bumper may fall.

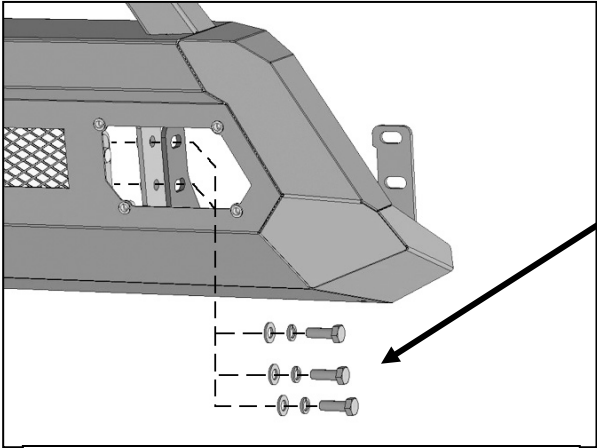

(Fig 14) Attach Bumper to Frame Brackets

- (3) 10mm x 30mm Hex Bolts
- (3) 10mm Lock Washers
- (3) 10mm Flat Washers

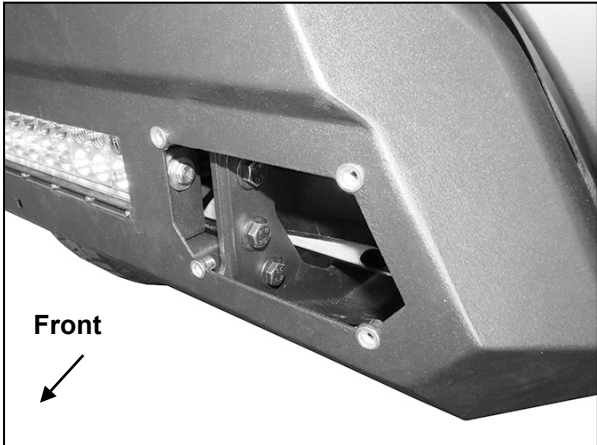

(Fig 15) Driver/left side of Bumper attached

- (4) 6mm Combo Bolts

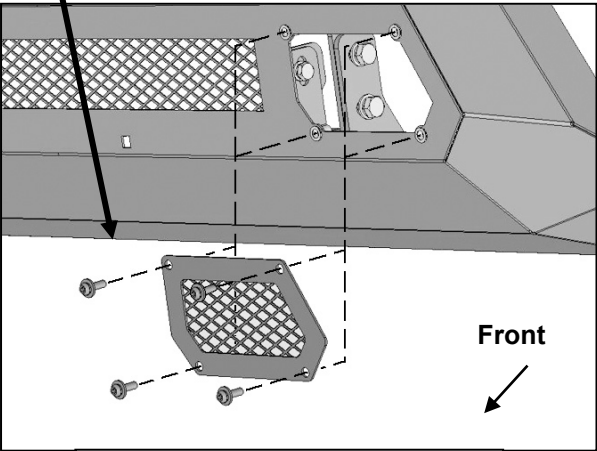

(Fig 16) Attach Mesh Fill Panels  
(driver/left side illustrated)

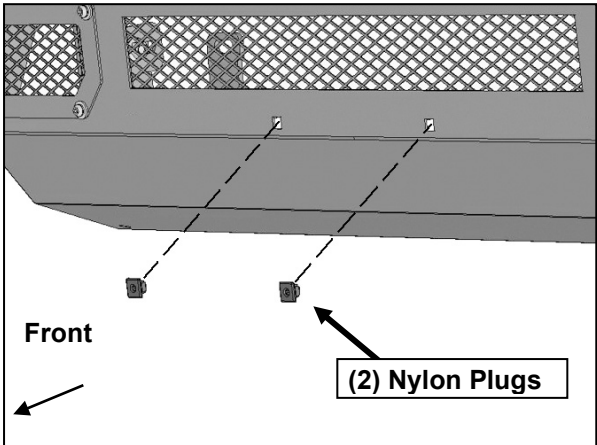

(Fig 17) Attach License Plate to Plastic Plugs