

# **INSTALLATION INSTRUCTIONS**

**CS-1 LD FRONT BUMPER  
2016-2003 TOYOTA TACOMA  
TT1341/TT1342**

**PARTS LIST:**

1	CS-1 "LD" Front Bumper	2	12mm x 32mm x 3mm Flat Washers
1	Center Mesh Fill Panel	2	12mm Nylon Lock Nuts
1	Driver/left Mesh Fill Panel	6	10-1.5mm x 30mm Hex Bolts
1	Passenger/right Mesh Fill Panel	6	10mm x 20mm x 2mm Flat Washers
1	Driver/left Frame Mounting Bracket	6	10mm Lock Washers
1	Passenger/right Frame Mounting Bracket	6	8-1.25mm x 25mm Hex Bolts
1	Driver/left "L" Top Light Bracket	2	8-1.25mm x 16mm Hex Bolts
1	Passenger/right "L" Top Light Bracket	14	8mm x 24mm x 2mm Flat Washers
2	Inner "L" Brackets for mesh or light	8	8mm Lock Washer
2	Plastic Plugs for License Plate	6	8mm Hex Nut
1	2000mm Edge Trim	10	6mm x 20mm Button Head Combo Bolts
2	Rectangular Spacers for Frame Brackets	2	6mm Flange Nuts
2	12-1.75mm x 120mm Hex Bolts	1	4mm Wrench
2	12mm x 44mm x 4mm Large Spacer Washers	10	Nylon Wire Ties

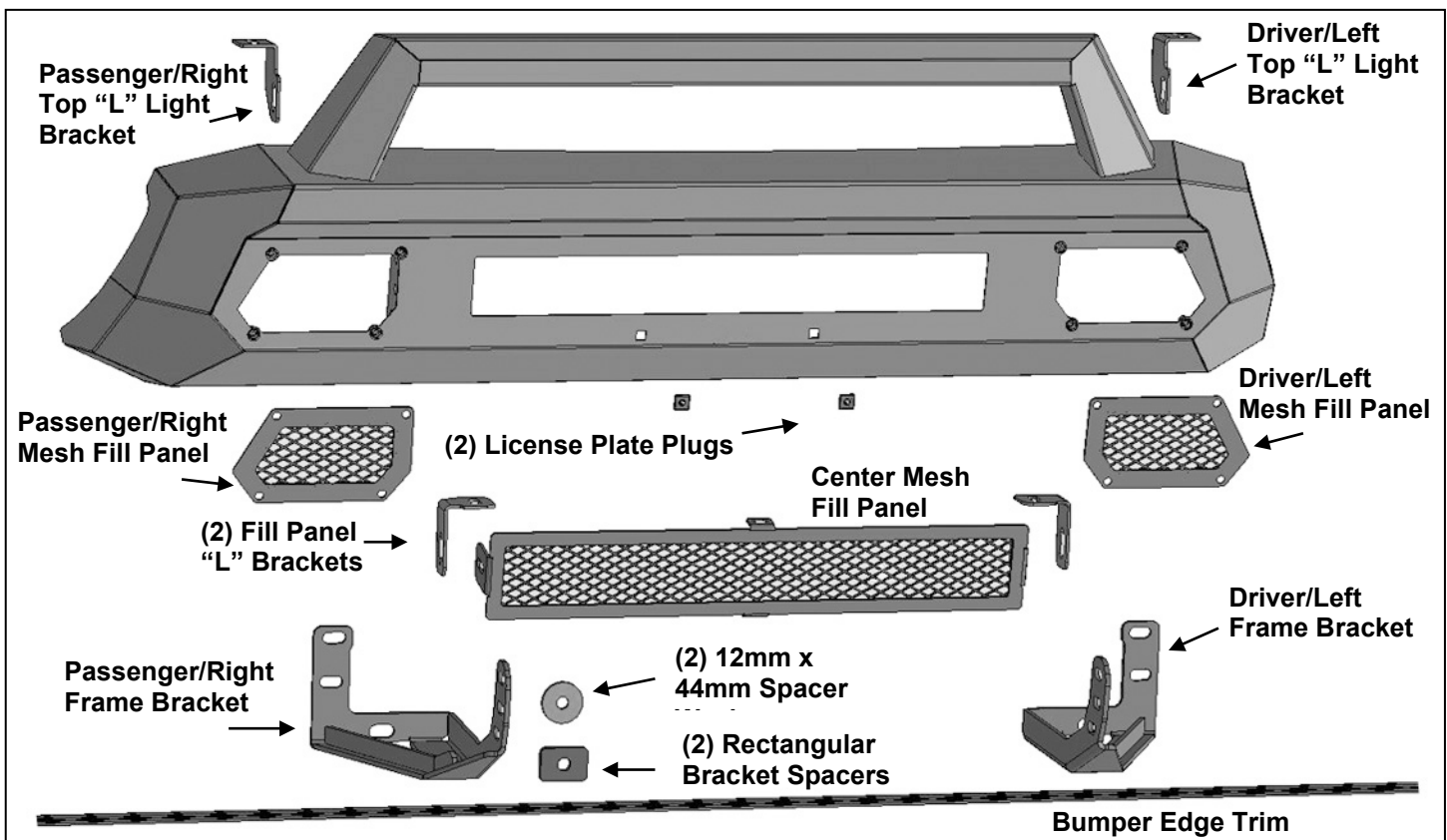

**PROCEDURE:**

**REMOVE CONTENTS FROM BOX. VERIFY ALL PARTS ARE PRESENT. READ INSTRUCTIONS CAREFULLY BEFORE STARTING INSTALLATION. ASSISTANCE IS HIGHLY RECOMMENDED TO AVOID POSSIBLE INJURY OR DAMAGE TO THE VEHICLE. CUTTING MAY BE REQUIRED.**

1. Remove the license plate and bracket from the bumper cover, **(Figure 1)**.
2. Remove the air dam attached to the bottom of the bumper cover, **(Figures 1 & 2)**. **NOTE:** The air dam is attached to the bottom of the main bumper cover with several captive clip nuts. Remove the clip nuts from the cover to prevent rattles (optional).
3. Locate and remove the clips (1 per side) from the back of the bumper cover attaching the ends of the outer cover, **(Figure 3)**. Pull the outer center cover off of the main bumper cover. **NOTE:** The bumper cover does not need to be removed to remove the outer cover but it is optional.
4. Next, remove the plastic pad from the aluminum impact bumper, **(Figure 4)**.
5. Remove the (2) outer hex nuts attaching the driver/left impact bumper bracket to the frame, **(Figure 4)**.

6. Select the driver/left Frame Bracket, **(Figure 5)**. Reuse the (2) factory hex nuts to attach the Bracket over the impact bumper bracket, **(Figures 5 & 67)**. Leave hardware loose at this time.
7. Insert (1) 12mm x 120mm Hex Bolt with (1) 12mm x 44mm Spacer Washer through the back of the frame crossmember. Slide (1) Rectangular Spacer between the Bracket and the front of the crossmember, **(Figure 6)**. Guide the long Hex Bolt through the Spacer and Bumper Bracket. Secure the Bracket to the long Hex Bolt with (1) 12mm x 32mm STD Flat washer and (1) 12mm Nylon Lock Nut, **(Figures 6 & 7)**. Snug but do not fully tighten Bumper Bracket hardware at this time.
8. Repeat **Steps 5—7** to install the passenger/right Frame Bracket.
9. Determine if accessory lights, (not included), or Screen Fill Panels will be installed at this time.

**IMPORTANT:** It may be easier to install Center Fill Panels and/or lights before installing Bumper.

**Inner Screen Fill Panel Installation (do not install Center Fill Panel if installing light).**

- a. Select (1) “L” Light Bar Bracket, **(Figure 8)**.
- b. Attach the “L” Bracket to the slot on the back of the driver/left side of the Bumper with (1) 8mm x 25mm Hex Bolt, (2) 8mm Flat Washers, (1) 8mm Lock Washer and (1) 8mm Hex Nut, **(Figure 8)**. Repeat this Step to attach the “L” Bracket to the passenger/right side of the Bumper.
- c. Select the center Screen Fill Panel, **(Figure 9)**.
- d. Attach the Screen to the “L” Brackets with the included (2) 8mm x 25mm Hex Bolts, (4) 8mm Flat Washers, (2) 8mm Lock Washers and (2) 8mm Hex Nuts, **(Figure 9)**. Do not fully tighten hardware at this time.
- e. Attach the center of the Screen Fill Panel to the top and bottom of the opening in the Bumper with the included (2) 6mm Button Head Combo Bolts and (2) 6mm Flange Nuts, **(Figure 9)**. Push the Screen up against the back of the Bumper and fully tighten Fill Panel hardware only.

**Inner center LED bar style light installation (20” light not included-do not install Mesh Panel with light).**

- a. Select (1) “L” Light Bar Bracket, **(Figure 8)**.
- b. Attach the “L” Bracket to the slot on the back of the driver/left side of the Bumper with (1) 8mm x 25mm Hex Bolt, (2) 8mm Flat Washers, (1) 8mm Lock Washer and (1) 8mm Hex Nut, **(Figure 8)**. Repeat this Step to attach the “L” Bracket to the passenger/right side of the Bumper.
- c. Attach the light to the “L” Brackets with the hardware included with the light or the supplied (2) 8mm x 16mm Hex Bolts, (2) 8mm Lock Washers and (2) 8mm Flat Washers, **(Figure 10)**. Adjust and fully tighten light and “L” bracket hardware only at this time.

**Top mounted 20” bar style LED light (not included).**

- a. Select the driver/left Top Light Bracket. Attach the Bracket to the slot on the back of the Bumper Hoop with (1) 8mm x 25mm Hex Bolt, (2) 8mm Flat Washers, (1) 8mm Lock Washer and (1) 8mm Hex Nut, **(Figure 11)**. Do not tighten hardware at this time.
  - b. Repeat previous Step to attach the passenger/right Bracket.
  - c. Select the 20” light, (not included). Attach the light to the Top Light Brackets with the hardware included with the light or the supplied (2) 8mm x 16mm Hex Bolts, (2) 8mm Lock Washers and (2) 8mm Flat Washers, **(Figure 11)**. Adjust and fully tighten light and Bracket hardware only.
10. Apply the included Edge Trim to the Bumper to protect the plastic bumper cover. Cut Edge Trim to fit. With assistance, position the Bumper Assembly up to the outside of the Frame Brackets. Temporarily support the weight of the Bumper. **WARNING:** To avoid possible injury or damage to the vehicle, do not proceed until the Bumper is fully and safely supported.
  11. Line up the driver/left side mounting plate on the back of the Bumper with the Frame Bracket. Attach the Bumper to the Bracket with the included (3) 10mm x 30mm Hex Bolts, (3) 10mm Lock Washers and (3) 10mm Flat Washers, **(Figures 12 & 13)**. Do not fully tighten hardware at this time. Repeat this Step to attach the passenger/right side of Bumper.
  12. Level and adjust the bumper and fully tighten all hardware. **IMPORTANT:** Check fit between inner light, (if installed), and cut plastic bumper cover. Remove CS-1 Bumper and trim cover for proper fit if necessary, before fully tightening hardware. Once properly adjusted and trimmed, tighten hardware.
  13. Attach the Mesh Fill Panels to the Bumper with the included (8) 6mm Combo Bolts, **(Figure 14)**.
  14. Use the included (2) push-in Plastic Plugs to attach the front license plate, (if required), to the (2) holes in the front of the Bumper, **(Figure 15)**.
  15. Do periodic inspections to the installation to make sure that all hardware is secure and tight.

**To protect your investment,** Do not use any type of polish or wax that may contain abrasives that could damage the finish. Mild soap may be used to clean the Front Bumper assembly.

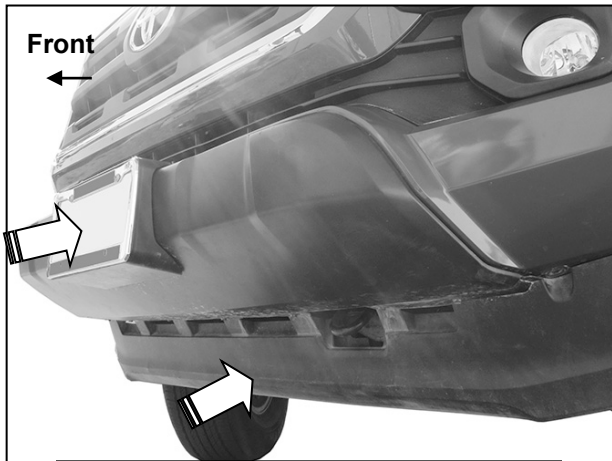

(Fig 1) Remove the license plate and air dam from front bumper cover

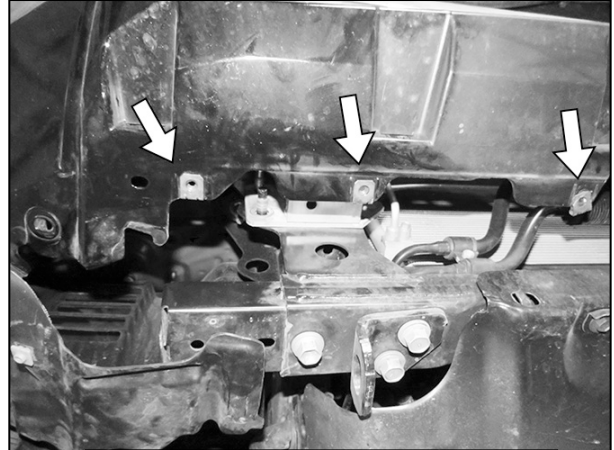

(Fig 2) Remove clip on nuts from bottom of bumper cover (arrows)

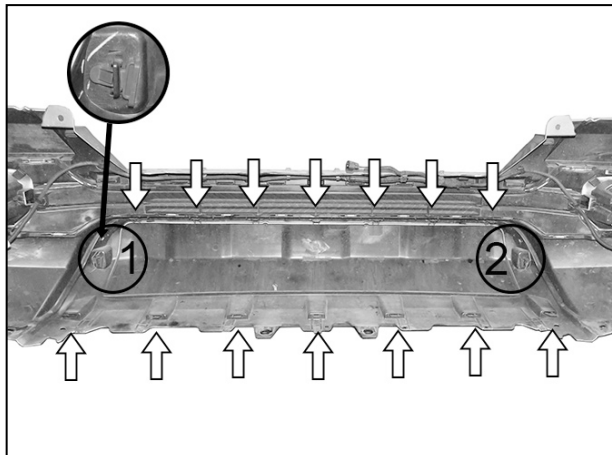

(Fig 3) Remove (2) outer clips from back of bumper cover, then release clips from top and bottom to remove center cover. NOTE: Bumper removal to release clips is optional



(Fig 4) Remove the (2) outer hex nuts from the driver/left aluminum impact bumper bracket. NOTE: Pictured with plastic bumper cover removed for instruction purposes only, it is not necessary to remove bumper cover

**Driver/left Side Installation Pictured**

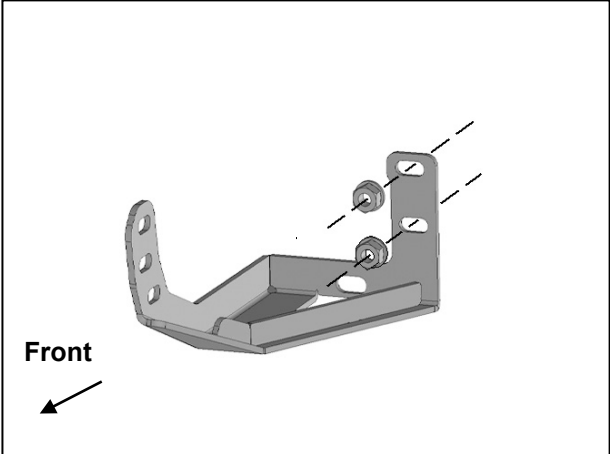

**(Fig 5) Reuse the (2) factory hex nuts to attach driver/left Frame Mounting Bracket to the inner impact bumper bracket**

**12mm x 32mm STD Flat Washer  
12mm Nylon Lock Nut**

**12mm x 120mm Hex Bolt  
12mm x 44mm Large Spacer Washer**

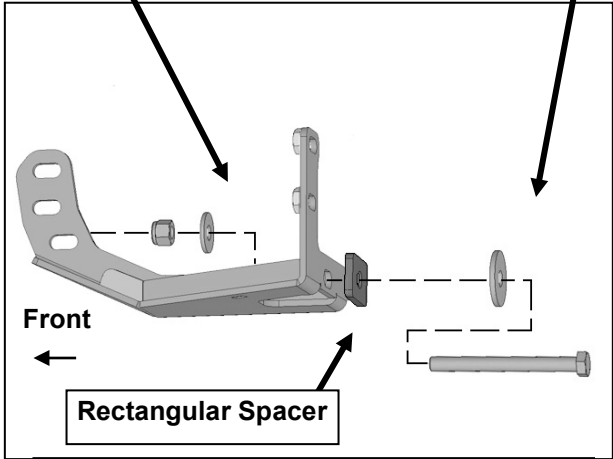

**(Fig 6) Insert Rectangular Spacer between Bracket and frame crossmember**

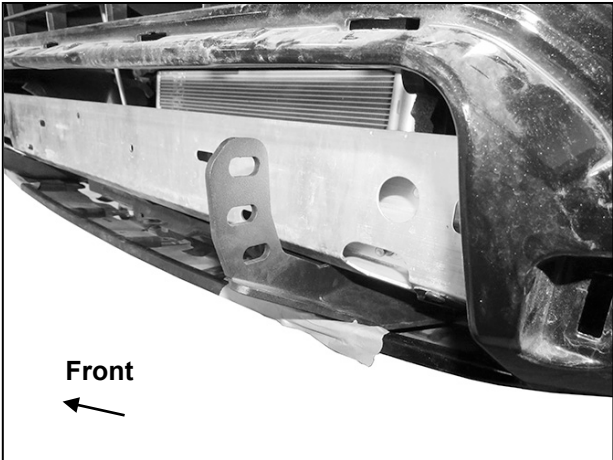

**(Fig 7) Driver/left Frame Bracket installed**

**8mm x 25mm Hex Bolt  
(2) 8mm Flat Washers  
8mm Lock Washer  
8mm Hex Nut**

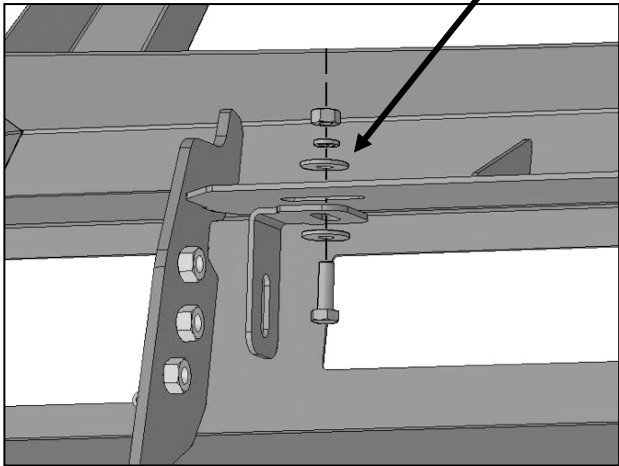

**(Fig 8) Attach inner "L" Bracket for Mesh Panel or inner bar style LED light installation (optional). Back of driver/left side illustrated**

Driver/left Side Installation Pictured

8mm x 25mm Hex Bolt  
(2) 8mm Flat Washers  
8mm Lock Washer  
8mm Hex Nut

(2) 6mm Combo Bolts  
(2) 6mm Flange Nuts

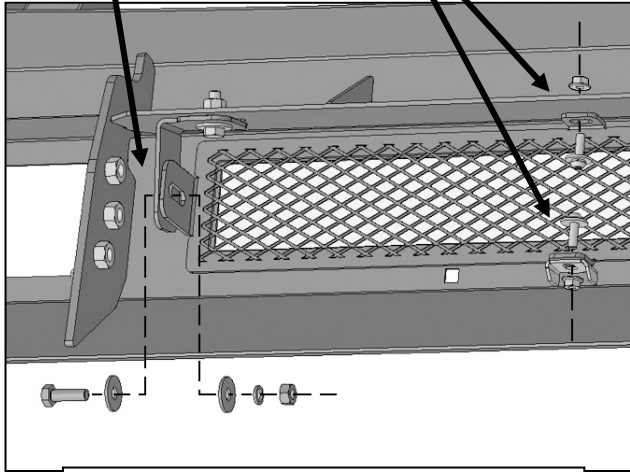

(Fig 9) Attach Mesh Fill Panel to "L" Brackets and tabs on back of Bumper

8mm x 16mm Hex Bolt  
8mm Lock Washer  
8mm Flat Washer

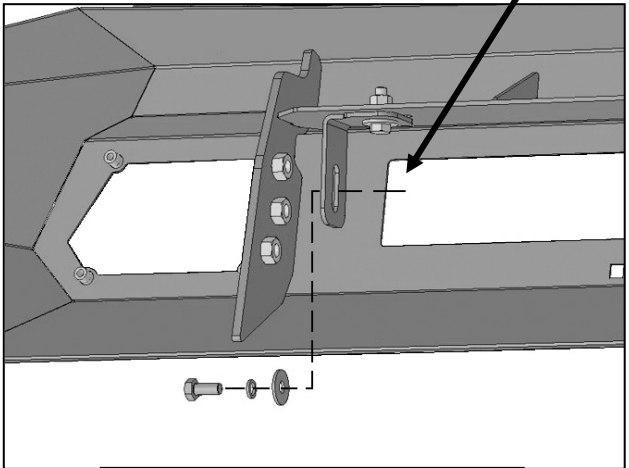

(Fig 10) Example bar style LED light to "L" Brackets (optional)

8mm x 16mm Hex Bolt  
8mm Lock Washer  
8mm Flat Washer

8mm x 25mm Hex Bolt  
(2) 8mm Flat Washers  
8mm Lock Washer  
8mm Hex Nut

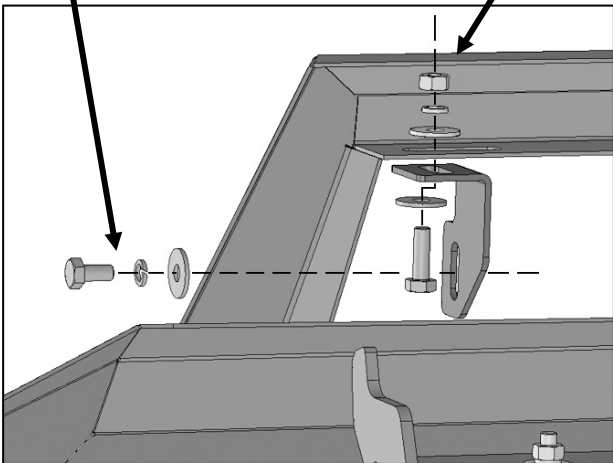

(Fig 11) Driver/left Top Light Bracket installed

**WARNING!** Do not crawl under bumper unless it is properly supported on blocks or stands or the bumper may fall.

(3) 10mm x 30mm Hex Bolts  
(3) 10mm Lock Washers  
(3) 10mm Flat Washers

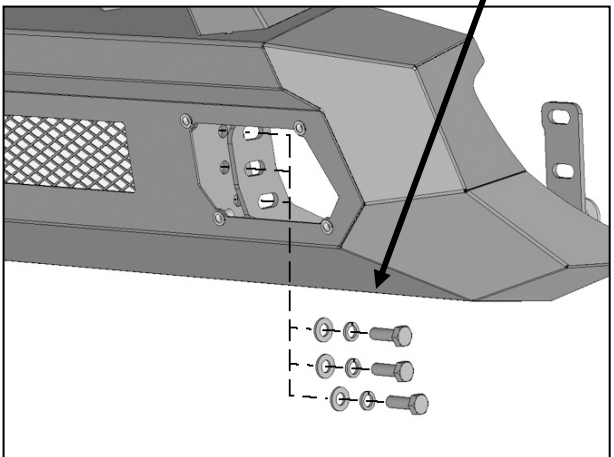

(Fig 12) Attach Bumper to Frame Brackets

**Driver/left Side Installation Pictured**



**(Fig 13) Driver/left side of Bumper attached**

**(4) 6mm Combo Bolts**

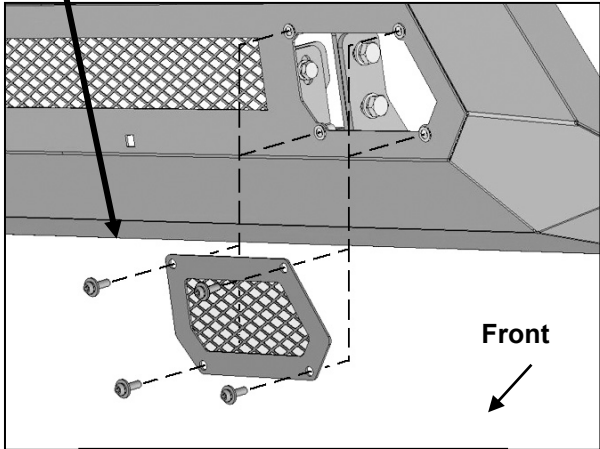

**(Fig 16) Attach Mesh Fill Panels  
(driver/left side illustrated)**

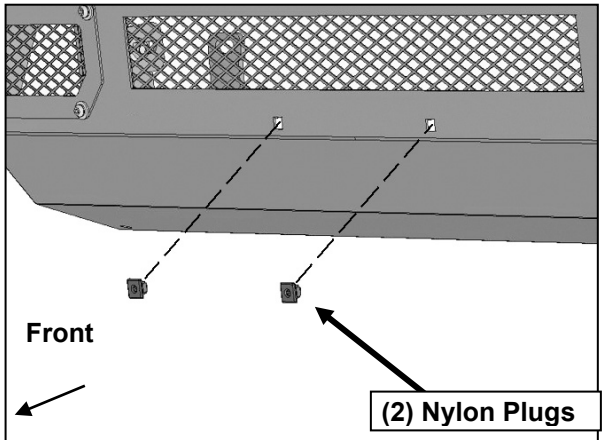

**(2) Nylon Plugs**

**(Fig 17) Attach License Plate to Plastic Plugs**



**Complete Installation (light not included)**