

PARTS LIST: TT1060 TT1062

1	Driver/left Side Step	12	8-1.25mm x 30mm Hex Bolts
1	Passenger/right Side Step	12	8mm x 24mm OD x 2mm Flat Washers
1	Driver/Left Front Mounting Bracket	12	8mm Lock Washers
1	Passenger/Right Front Mounting Bracket	12	8-1.25mm x 25mm Combination Bolts
2	Driver/Left Center and Rear Mounting Brackets	12	Plastic Clips
2	Passenger/Right Center and Rear Mounting Brackets	6	Plastic Covers

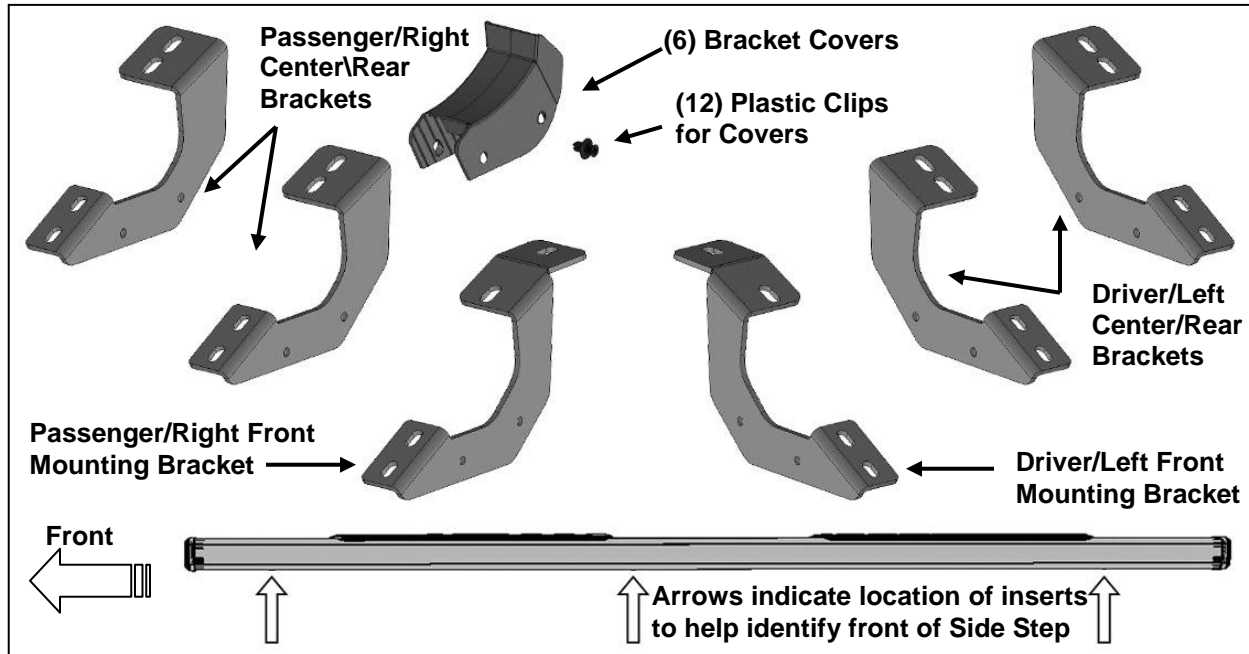

PROCEDURE:

- 1. REMOVE CONTENTS FROM BOX. VERIFY ALL PARTS ARE PRESENT. READ INSTRUCTIONS CAREFULLY. USE ILLUSTRATION TO PROPERLY IDENTIFY BRACKETS AND SIDEBARS.**
- Starting on the passenger side front of the vehicle, remove the plastic plugs or bolts covering the threaded holes in the body panel, (**Figure 1**). Select the passenger side front Mounting Bracket, (**Figures 2 & 3**). Attach the Bracket to the vehicle using the included (2) 8mm x 30mm Hex Bolts, (2) 8mm Lock Washers and (2) 8mm Flat Washers, (**Figure 2**). Do not tighten hardware at this time.
- Select (1) Plastic Bracket Cover and (2) Retaining Clips, (**Figure 3**). Slide the Cover over the front Bracket. Line up the mounting holes in the Cover with the holes in the Bracket. Insert (1) Clip into each hole and push center pin to expand Clip, (**Figure 4**). Repeat this Step for all Cover installations.
- Repeat **Steps 2 & 3** for Center and rear Mounting Bracket installation, (**Figures 5 & 6**).
- Select the passenger/right Side Step. Carefully position the Side Step onto the (3) Mounting Brackets. **IMPORTANT:** Do not slide the Side Step on the Brackets or damage to the finish may result. Attach the Side Step to the Mounting Brackets with (6) 8mm x 25mm Combination Hex Bolts, (**Figures 7 & 8**). Do not tighten hardware.
- Level and adjust the Side Step and fully tighten all hardware.
- Repeat **Steps 2—6** for driver Side Step installation.
- Do periodic inspections to the installation to make sure that all hardware is secure and tight.

To protect your investment, wax this product after installing. Regular waxing is recommended to add a protective layer over the finish. Do not use any type of polish or wax that may contain abrasives that could damage the finish.

For stainless steel: Aluminum polish may be used to polish small scratches and scuffs on the finish. Mild soap may be used also to clean the Side Step.

For gloss black finishes: Mild soap may be used to clean the Side Step.

Passenger/right Side Installation Pictured

Remove plastic plugs or
factory hex bolts (if equipped)

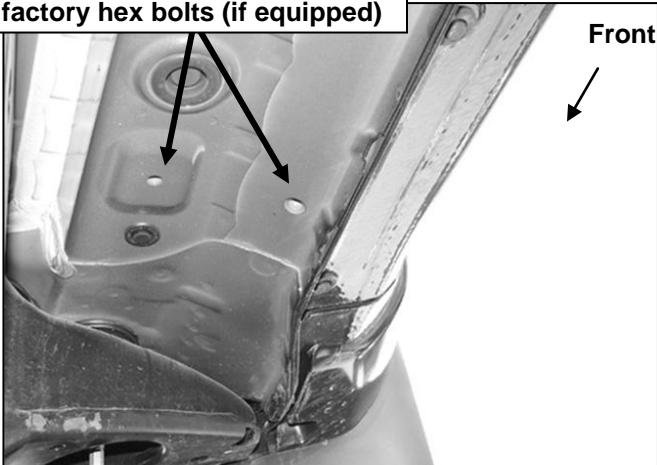

(Fig 1) Passenger side front mounting location

(2) 8mm x 30mm Hex Bolts
(2) 8mm Flat Washers
(2) 8mm Lock Washers

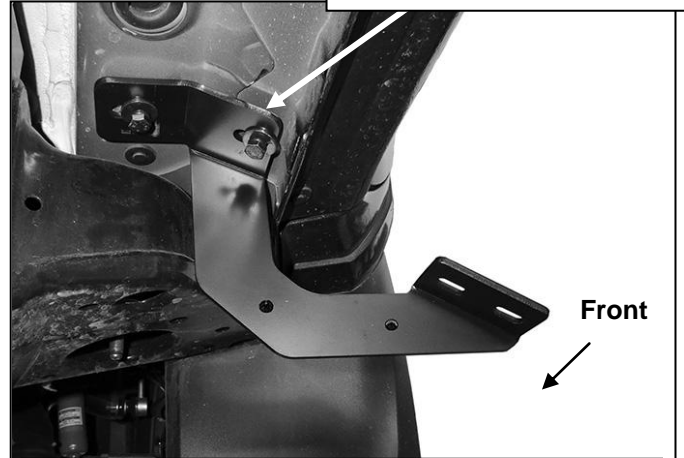

(Fig 2) Passenger side front Bracket installation

(2) Plastic Clips
for cover

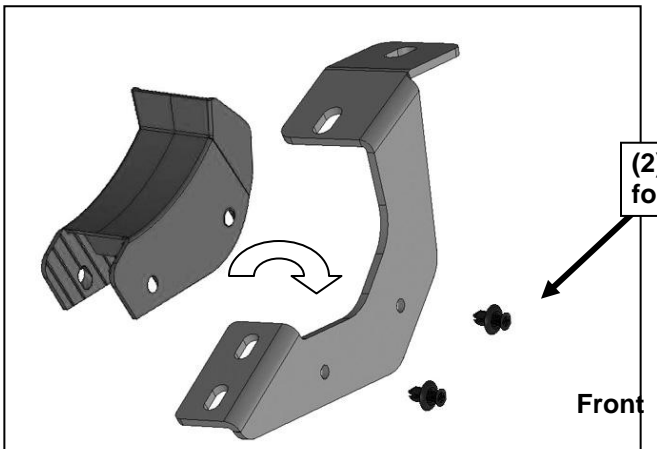

(Fig 3) Passenger front Bracket cover installation

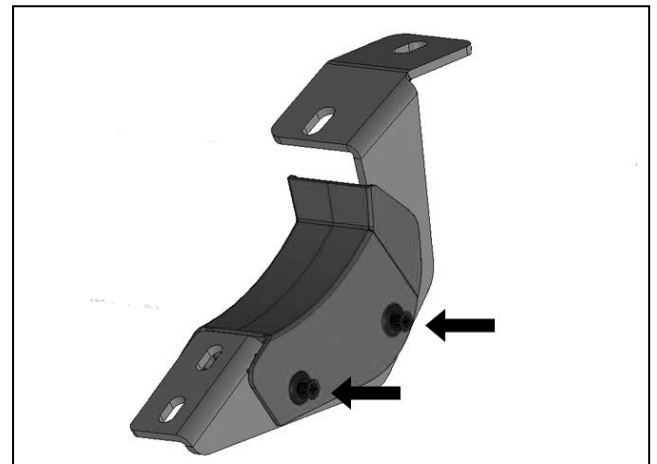

(Fig 4) Push center pin in to expand Clip in Bracket

Remove plastic plugs or
factory hex bolts (if equipped)

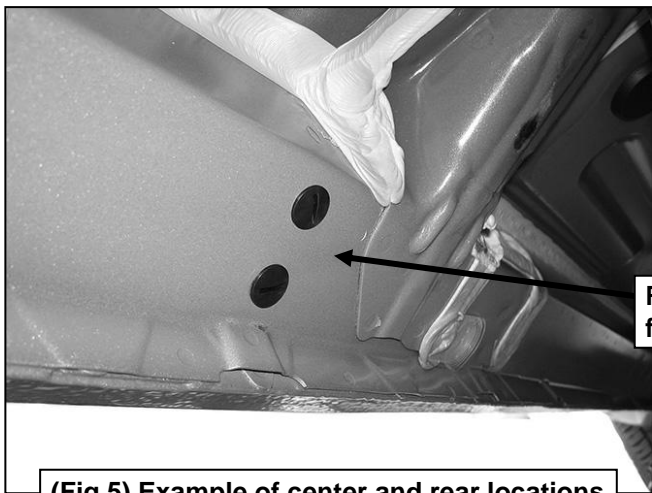

(Fig 5) Example of center and rear locations

Passenger/right Side Installation Pictured

