

7929 Lincoln Ave. Riverside, CA 92504
Phone: 951.689.ICON | Fax: 951.689.1016

PART #	DESCRIPTION
52700	07-14 FJ CRUISER/03-UP 4RUNNER/03-UP GX470/10-UP GX460 2" REAR COIL SPRING KIT

COMPONENTS INCLUDED	
(2) 158506 FJ/4RNR/GX 2" REAR LINEAR COIL	
HARDWARE INCLUDED	
N/A	
TOOLS REQUIRED	
JACK JACK STANDS TORQUE WRENCH	12MM SOCKET / WRENCH 17MM SOCKET / WRENCH 19MM SOCKET / WRENCH 21MM SOCKET / WRENCH
TECH NOTES	
<p>1. FOR HEAVILY LOADED VEHICLES, ICON HAS A 3" DUAL RATE REAR SPRING KIT AVAILABLE (52800).</p> <p>2. IF USING ON A LEXUS GX460/GX470, ICON COIL CONVERSION KIT (56110) MUST BE USED.</p>	



WARNING!
<p>** READ ALL INSTRUCTIONS THOROUGHLY FROM START TO FINISH BEFORE BEGINNING INSTALLATION! IF THESE INSTRUCTIONS ARE NOT PROPERLY FOLLOWED SEVERE FRAME, SUSPENSION AND TIRE DAMAGE MAY RESULT TO THE VEHICLE!</p> <p>** ICON VEHICLE DYNAMICS RECOMMENDS THAT YOU EXERCISE EXTREME CAUTION WHEN WORKING UNDER A VEHICLE THAT IS SUPPORTED WITH JACK STANDS.</p> <p>** ICON VEHICLE DYNAMICS RECOMMENDS ALL INSTALLTION TO BE PERFORMED BY A PROFESSIONAL SHOP/SERVICE TECHNICIAN. PRODUCT FAILURE CAUSED BY IMPROPER INSTALLATION WILL NOT BE COVERED UNDER ICON'S WARRANTY POLICY.</p>

INSTALLATION

- Using a properly rated jack, raise the rear of the vehicle and support the frame rails with jack stands. Ensure the jack stands are secure and set properly before lowering the jack. NEVER WORK UNDER AN UNSUPPORTED VEHICLE. Remove the rear wheels.
- Using a jack, support the rear axle then disconnect the sway bar links and shocks from the axle. Remove the clips that hold the ABS wires and brake lines to the axle. This is necessary to create enough room to install the new springs.
- Remove the track bar bolt at the axle to allow the rear end to cycle to full extension.
- Remove the stock springs. Due to rubber bushing stiffness you may need to pull down on the suspension. If it is still too stiff to remove the spring then you may loosen the bolts on the control arms.
- Slowly lower the axle and the coils will unload from the mounts so that you can remove them. Remove the rubber isolator from the stock coil and install it on the new coils.
- Install the ICON springs with the pig tail in the same orientation as the factory springs, make sure the springs are seated properly.
- Reinstall the brake lines and ABS wires into their clips. Reinstall the sway bar links, shocks, and track bar.
- Install wheels and lower vehicle to the ground. [Torque to factory spec]
- If you loosened control arm bolts, then retighten them when the vehicle is sitting on the ground and at ride height.

VERIFY ALL FASTENERS ARE PROPERLY TORQUED BEFORE DRIVING VEHICLE.

RETORQUE ALL NUTS, BOLTS AND LUGS AFTER 100 MILES AND PERIODICALLY THEREAFTER.

ICON VEHICLE DYNAMICS LIMITED LIFETIME WARRANTY

ICON Vehicle Dynamics warrants to the original retail purchaser who owns the vehicle on which the product was originally installed. ICON Vehicle Dynamics does not warrant the product for finish, alterations, modifications and/or installation contrary to ICON Vehicle Dynamics instructions. ICON Vehicle Dynamics products are not designed, nor are they intended to be installed on vehicles used in race applications, for racing purposes or for similar activities. (A "race" is defined as any contest between two or more vehicles, or a contest of one or more vehicles against the clock, whether or not such contest is for a prize). This warranty does not include coverage for police or taxi vehicles, race vehicles, or vehicles used for government or commercial purposes. Also excluded from this warranty are sales outside of the United States of America and Canada.

ICON Vehicle Dynamics' obligation under this warranty is limited to the repair or replacement, at ICON Vehicle Dynamics' discretion, of the defective product. Any and all costs of removal, installation or re-installation, freight charges and incidental or consequential damages are expressly excluded from this warranty. Items that are subject to wear are not considered defective when worn and are not covered.

ICON Vehicle Dynamics components must be installed as a complete kit as shown in our current application guide. Any substitutions or exemptions of required components will immediately void the warranty. Some finish damage may happen to parts during shipping and is not covered under warranty.

This warranty is expressly in lieu of all other warranties expressed or implied. This warranty shall not apply to any product that has been improperly installed, modified or customized subject to accident, negligence, abuse or misuse.



ICON VEHICLE DYNAMICS®
PERFORMANCE SUSPENSION SYSTEMS AND SHOCK ABSORBERS

7929 Lincoln Ave. Riverside, CA 92504 Phone: 951.689.ICON Fax: 951.689.1016
www.iconvehicledynamics.com



FOLLOW US ON FACEBOOK!



7929 Lincoln Ave. Riverside, CA 92504
 Phone: 951.689.ICON | Fax: 951.689.1016

PART #	DESCRIPTION
54000	07-UP FJ/03-UP 4RNR/08-UP LC 200/03-UP GX BILLET LOWER TRAILING ARM KIT

COMPONENTS INCLUDED	
(2) 157400 BILLET LOWER TRAILING ARM	
HARDWARE INCLUDED	
(2) 127005 HEIM SPACER JM16 X .570 X 2.625 (2) 157410 FJ LOWER ARM WEAR STRIP (2) 157420 NUT PLATE 3/8-16 X 2 (2) 157430 HEIM SPACER JM16 X .570 X 2.075 (2) 167014 L/R ADJ SLEEVE 1.25-12L / 1.00-14 (2) 219002 SLEEVE 1.375 X .565 X 2.365	(2) 295510 JM16-1T, 1-14 RH ROD END F1 FIT (4) 297035 HAT BUSHING 2.125 X 1.375 X 1.000 (2) 297038 LOAD RING 1.875 X 1.380 X .325 75D (14) 605018 10-32 X .438 FHSCS SS 18-8 RAW (4) 605146 3/8-16 X 1.500 12 PT FLANGED CAP SCREW (2) 605904 1/4-28 FLUSH STYLE ZERK FITTING
TOOLS REQUIRED	
JACK JACK STANDS TORQUE WRENCH BARREL SANDER	3/8" 12PT SOCKET / WRENCH 19MM SOCKET / WRENCH 21MM SOCKET / WRENCH 24MM SOCKET / WRENCH
TECH NOTES	
<p>1. DO NOT EXCEED 3.375" ADJUSTMENT FROM THE CENTER OF THE ROD END TO THE EDGE OF THE BILLET LINK. FAILURE CAUSED BY EXCESSIVE ADJUSTMENT WILL NOT BE COVERED UNDER ICON'S WARRANTY POLICY. REFER TO FIGURE 6.</p> <p>2. STOCK LINK LENGTH IS 26.75" EYE TO EYE.</p> <p>3. KDSS EQUIPPED VEHICLES WILL REQUIRE THE SYSTEM TO BE DEACTIVATED BEFORE INSTALLATION, AND REACTIVATED AFTER INSTALLATION IS COMPLETE. REFER TO FACTORY SERVICE MANUAL FOR MORE INFORMATION.</p>	

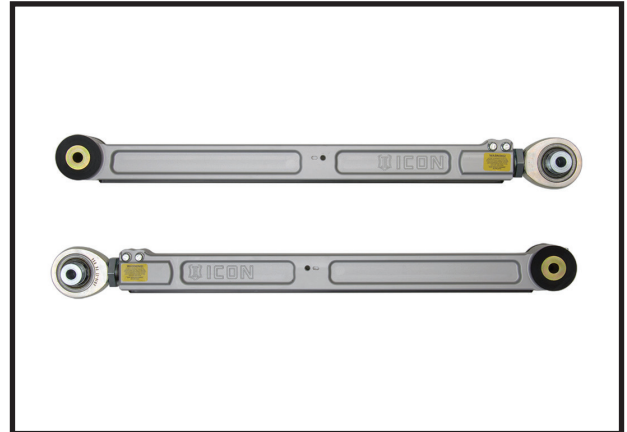

WARNING!
<p>** READ ALL INSTRUCTIONS THOROUGHLY FROM START TO FINISH BEFORE BEGINNING INSTALLATION! IF THESE INSTRUCTIONS ARE NOT PROPERLY FOLLOWED SEVERE FRAME, SUSPENSION AND TIRE DAMAGE MAY RESULT TO THE VEHICLE!</p> <p>** ICON VEHICLE DYNAMICS RECOMMENDS THAT YOU EXERCISE EXTREME CAUTION WHEN WORKING UNDER A VEHICLE THAT IS SUPPORTED WITH JACK STANDS.</p> <p>** ICON VEHICLE DYNAMICS RECOMMENDS ALL INSTALLATION TO BE PERFORMED BY A PROFESSIONAL SHOP/SERVICE TECHNICIAN. PRODUCT FAILURE CAUSED BY IMPROPER INSTALLATION WILL NOT BE COVERED UNDER ICON'S WARRANTY POLICY.</p>

INSTALLATION

1. If your vehicle is equipped with Kinetik Dynamic Suspension System (KDSS), deactivate the system before performing ANY work to the vehicle. Refer to the factory service manual for information on how to deactivate this system. KDSS will need to be reactivated once the installation is complete.
2. Using a properly rated jack, raise the rear of the vehicle and support the frame rails with jack stands. Ensure the jack stands are secure and set properly before lowering the jack. NEVER WORK UNDER AN UNSUPPORTED VEHICLE.
3. Assemble bushings into links with load ring sandwiched between hat bushings. Apply waterproof grease thoroughly. Failure to apply grease will cause premature wear and increased noise. [FIGURE 1]

FIG.1

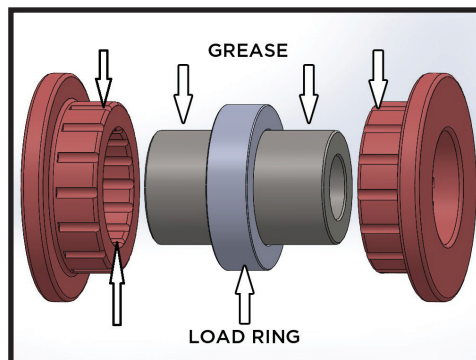

4. Remove one factory link at a time. Install the link in to the frame mount first with the short spacer towards the inside of the vehicle and the pinch bolt heads facing out. This moves the front link pivot points closer together on the frame and helps correct roll steer geometry on lifted vehicles. [FIGURE 2]

FIG.2

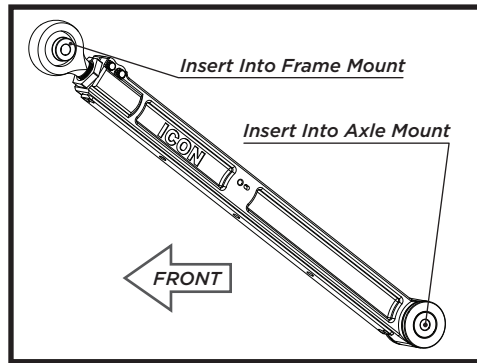

5. Some models may require trimming on the frame pocket for the lower links. Check to see if the link will contact the frame pocket with the suspension fully compressed. [FIGURE 3]

FIG.3



6. Mark the area of the pocket to be trimmed (if applicable). [FIGURE 4]

FIG.4

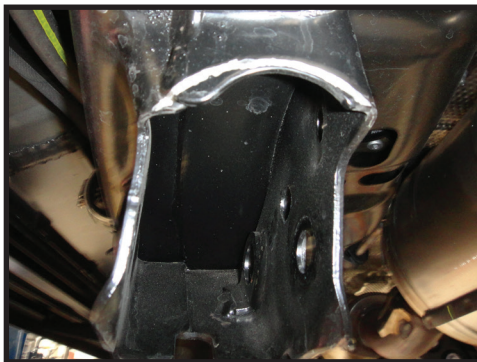
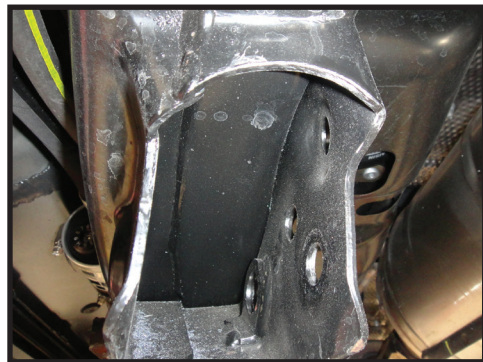

FIG.5



7. Trim as shown. Paint any exposed metal to prevent corrosion. [FIGURE 5]

8. If custom pinion angle is desired you can adjust this with the vehicle on the ground. Do not adjust further than 3.375" from the center of the rod end to the edge of the billet link. [FIGURE 6]

FIG.6

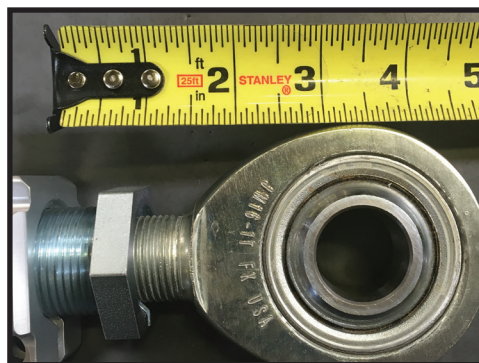

9. Repeat steps on the opposite side.

10. Make sure that the slots are lined up and then tighten pinch bolts [Torque to 40 ft-lbs]. Go back and forth between bolts 3 times to torque equally.

11. Tighten factory bolts to factory spec. Fasten E-brake mount to billet link using the factory hardware. [FIGURE 7]

FIG.7



VERIFY ALL FASTENERS ARE PROPERLY TORQUED BEFORE DRIVING VEHICLE.

RETORQUE ALL NUTS, BOLTS AND LUGS AFTER 100 MILES AND PERIODICALLY THEREAFTER.

ICON VEHICLE DYNAMICS LIMITED LIFETIME WARRANTY

ICON Vehicle Dynamics warrants to the original retail purchaser who owns the vehicle on which the product was originally installed. ICON Vehicle Dynamics does not warrant the product for finish, alterations, modifications and/or installation contrary to ICON Vehicle Dynamics instructions. ICON Vehicle Dynamics products are not designed, nor are they intended to be installed on vehicles used in race applications, for racing purposes or for similar activities. (A "race" is defined as any contest between two or more vehicles, or a contest of one or more vehicles against the clock, whether or not such contest is for a prize). This warranty does not include coverage for police or taxi vehicles, race vehicles, or vehicles used for government or commercial purposes. Also excluded from this warranty are sales outside of the United States of America and Canada.

ICON Vehicle Dynamics' obligation under this warranty is limited to the repair or replacement, at ICON Vehicle Dynamics' discretion, of the defective product. Any and all costs of removal, installation or re-installation, freight charges and incidental or consequential damages are expressly excluded from this warranty. Items that are subject to wear are not considered defective when worn and are not covered.

ICON Vehicle Dynamics components must be installed as a complete kit as shown in our current application guide. Any substitutions or exemptions of required components will immediately void the warranty. Some finish damage may happen to parts during shipping and is not covered under warranty.

This warranty is expressly in lieu of all other warranties expressed or implied. This warranty shall not apply to any product that has been improperly installed, modified or customized subject to accident, negligence, abuse or misuse.



ICON VEHICLE DYNAMICS®
PERFORMANCE SUSPENSION SYSTEMS AND SHOCK ABSORBERS

7929 Lincoln Ave. Riverside, CA 92504 Phone: 951.689.ICON Fax: 951.689.1016
www.iconvehicledynamics.com



FOLLOW US ON FACEBOOK!



7929 Lincoln Ave. Riverside, CA 92504
Phone: 951.689.ICON | Fax: 951.689.1016

PART #	DESCRIPTION
57810P	07-UP FJ/03-UP 4RNR/03-UP GX 1-3" REAR 2.5 VS RR PAIR

COMPONENTS INCLUDED	
(2) 154969R 07+ FJ/03+ 4RUNNER 0-3" REAR 2.5 RR (DRV) (2) 250002 7.50 UNIVERSAL RESI MT PLATE	(2) 611007 9/16" MED DUTY STEM BUSHING KIT (1) 611051 HOSE CLAMP KIT
HARDWARE INCLUDED	
(1) 605033 #14-14 X .750 #3 HWH SELF DRILL SCREW (2) 605131 3/8" SPLIT LOCK WASHER	(2) 605144 3/8-12 X .750 FLANGED SELF TAP BOLT (2) 605934 #12 (3/4) ADEL CLAMP
611007 HARDWARE KIT	
(2) MED DUTY 9/16" ID STEM BUSHING (1) MED DUTY 9/16" ID STEM WASHER	(1) MED DUTY 12MM ID STEM WASHER (1) M12-1.25 LOCK NUT
611051 HARDWARE KIT	
(4) STAINLESS STEEL HOSE CLAMP	
TOOLS REQUIRED	
JACK JACK STANDS DRILL CENTER PUNCH 21/64 DRILL BIT LOCKING PLIERS TORQUE WRENCH	8MM NUT DRIVER 3/8" SOCKET (FOR IMPACT DRIVER) 10MM SOCKET / WRENCH 14MM SOCKET / WRENCH 15MM SOCKET / WRENCH 17MM SOCKET / WRENCH 19MM SOCKET / WRENCH
TECH NOTES	
1. YOUR ICON SHOCK ASSEMBLIES COME FACTORY CHARGED TO 250 PSI. RELEASING NITROGEN PRESSURE MAY LEAD TO SHOCK MALFUNCTION AND REDUCED RIDE QUALITY. FAILURE CAUSED BY LOW NITROGEN PRESSURE IS NOT COVERED UNDER ICON'S WARRANTY POLICY.	
2. DRIVER AND PASSENGER SHOCKS DIFFER ONLY BY RESERVOIR STICKER ORIENTATION	
3. KDSS EQUIPPED VEHICLES WILL REQUIRE THE SYSTEM TO BE DEACTIVATED BEFORE INSTALLATION, AND REACTIVATED AFTER INSTALLATION IS COMPLETE. REFER TO FACTORY SERVICE MANUAL FOR MORE INFORMATION.	



WARNING!
** READ ALL INSTRUCTIONS THOROUGHLY FROM START TO FINISH BEFORE BEGINNING INSTALLATION! IF THESE INSTRUCTIONS ARE NOT PROPERLY FOLLOWED SEVERE FRAME, SUSPENSION AND TIRE DAMAGE MAY RESULT TO THE VEHICLE!
** ICON VEHICLE DYNAMICS RECOMMENDS THAT YOU EXERCISE EXTREME CAUTION WHEN WORKING UNDER A VEHICLE THAT IS SUPPORTED WITH JACK STANDS.
** ICON VEHICLE DYNAMICS RECOMMENDS ALL INSTALLATION TO BE PERFORMED BY A PROFESSIONAL SHOP/SERVICE TECHNICIAN. PRODUCT FAILURE CAUSED BY IMPROPER INSTALLATION WILL NOT BE COVERED UNDER ICON'S WARRANTY POLICY.

INSTALLATION

- If your vehicle is equipped with Kinetik Dynamic Suspension System (KDSS), deactivate the system before performing ANY work to the vehicle. Refer to the factory service manual for information on how to deactivate this system. KDSS will need to be reactivated once the installation is complete.
- Using a properly rated jack, raise the rear of the vehicle and support the frame rails with jack stands. Ensure the jack stands are secure and set properly before lowering the jack. NEVER WORK UNDER AN UNSUPPORTED VEHICLE. Remove the rear wheels.
- Place a floor jack under the axle housing and slightly raise the jack to remove tension from the shock. Loosen and remove the lower shock bolt using a 17mm socket/wrench. Make sure the axle is well supported, then remove the stem bushing nut and upper stem bushings using a 17mm socket/wrench.
- Remove the rear shock.
- Install the lower shock mount as follows: shock spacer, shock rod end, shock spacer, shin guard (56100)*, factory stud bolt. [Torque to factory spec] *(56100 shin guard optional) **NOTE:** If factory shock mount has been deformed, sand slightly to allow for proper spacer fitment.
- Use a jack to raise the axle housing far enough to guide the shock stem into position in the factory shock mount. Install stem hardware as seen in diagram. Use a 19mm socket/wrench to install the lock nut until lock is engaged. Do not overtighten bushing assembly as this can lead to premature bushing wear. Failure caused by incorrect installation of bushings is not covered under ICON's warranty policy.
- Use a 10mm socket/wrench to remove the (4) bolts and rivet clip that holds the driver side mud flap in place. Remove mud flap.

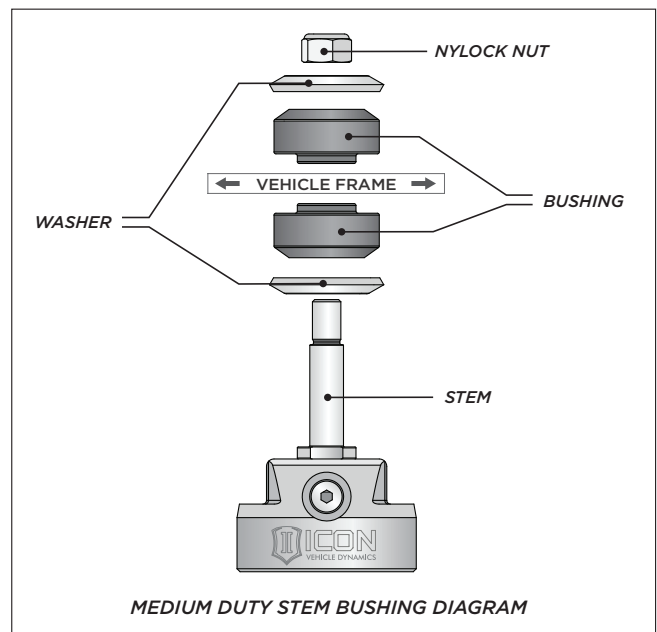

8. Reservoir hose should be oriented towards the rear of the vehicle. Mount the remote reservoir to the reservoir mount plate (250002) using the provided (605931) hose clamps. Be sure to install the hose clamp to the ends of the reservoir within the machined areas on the outer surface of the remote reservoir.

9. Orient the reservoir mounting bracket on frame rail forward of the body mount and mark center of the hole. The remote reservoir and bracket should not come in contact with any part of the frame or frame brackets. The reservoir bracket bolt can be measured to within the following approximate dimensions: 2" up from the bottom of the frame rail and 4" forward of the body mount. [FIGURE 1]

FIG.1



10. Using the hole in the bracket as a guide, center punch and drill to 21/64".

11. Use a 9/16" socket/wrench to thread the supplied (605144) self tap bolt into the frame rail, minimum 2 full rotations.

12. Remove the (605144) self tap bolt and secure remote reservoir bracket. [Torque to 30ft-lbs]

13. Place reservoir in the reservoir mounting bracket with the ICON shield logo oriented up into the fender well and secure reservoir with the supplied (605931) hose clamps using an 8mm nut driver. [FIGURE 2]

FIG.2



FIG.3



14. Install the supplied (605934) adel clamp at the center of the remote reservoir hose in the fender well. Use a 3/8" socket to drive the #14 self drill/tap screw (605033) and secure adel clamp to the pinch weld above the frame in the wheel well. [FIGURE 3]

15. Use a 10mm socket/wrench to reinstall the mud flap and rivet clip.

16. Repeat steps 3-15 on opposite side.

17. Install wheels and lower vehicle back to the ground. [Torque to factory spec]

VERIFY ALL FASTENERS ARE PROPERLY TORQUED BEFORE DRIVING VEHICLE.

RETORQUE ALL NUTS, BOLTS AND LUGS AFTER 100 MILES AND PERIODICALLY THEREAFTER.

2.5 VS SERIES SHOCK & COILOVER TECHNICAL INFORMATION

MAINTENANCE

ICON shock absorbers are a high quality rebuildable race style shock absorber designed for optimal performance. With a unit of this caliber on your vehicle, routine maintenance is required to keep them looking and operating in like new condition. Residual oil and assembly lube may be present at all seal paths from the factory out of the box and is considered normal. Pooling of oil however is not acceptable at any time and one should contact the ICON dealer where purchased.

BELOW ARE GUIDELINES BASED ON HOW YOU USE YOUR VEHICLE BUT YOUR MILEAGE MAY VARY:

STREET USE:

- Send in for factory servicing every 40,000 miles or if a leak develops, ride quality decreases, or they begin to make excessive noise.
- Remove any buildup of road salt, mud, or debris from shocks and coil springs anytime accrued
- Clean with mild soap and water with each oil change or anytime you notice build up.
- Wax the cylinders yearly with automotive wax to prevent corrosion.
- Check nitrogen pressure yearly. (252004 charge needle assembly available at any ICON distributor)
- Check bearings for excessive wear yearly.
- DO NOT apply any type of lube to the upper and lower bearings.

STREET/DIRT:

- Send in for factory servicing every 15,000 miles or if a leak develops, ride quality decreases, or they begin to make excessive noise.
- Clean with mild soap and water with each oil change, offroad trip, or anytime you notice build up.
- Wax the cylinders yearly with automotive wax to prevent corrosion.
- Check nitrogen pressure each dirt outing. (252004 charge needle assembly available at any ICON distributor)
- Check bearings for excessive wear yearly.
- DO NOT apply any type of lube to the upper and lower bearings.

DIRT USE:

- Send in for factory servicing every 1,000 miles.
- Check nitrogen pressure each outing. (252004 charge needle assembly available at any ICON distributor)
- Remove any buildup of mud or debris from shocks and coil springs after every outing.

SELF-SERVICE:

- Contact ICON for service kits & tools at (951) 689-4266.

PRODUCT REGISTRATION

Please visit: <http://www.iconvehicledynamics.com/tech-support/registration/> to register your product.

ICON VEHICLE DYNAMICS SHOCK ABSORBER WARRANTY

This shock absorber has a 1 year warranty against any manufacturer's defects. If a shock fails within the initial year of ownership, the shock must be shipped to ICON Vehicle Dynamics for inspection and service. If a shock is inspected and it has been determined the shock failed due to neglect, damage caused by improper installation or any other reason besides "normal wear and tear", the owner of said shock is responsible for all service costs. This includes labor, parts, and shipping.

ICON Vehicle Dynamics warrants to the original retail purchaser who owns the vehicle on which the product was originally installed. ICON Vehicle Dynamics does not warrant the product for finish, alterations, modifications and/or installation contrary to ICON Vehicle Dynamics instructions. ICON Vehicle Dynamics products are not designed, nor are they intended to be installed on vehicles used in race applications, for racing purposes or for similar activities. (A "race" is defined as any contest between two or more vehicles, or a contest of one or more vehicles against the clock, whether or not such contest is for a prize). This warranty does not include coverage for police or taxi vehicles, race vehicles, or vehicles used for government or commercial purposes. Also excluded from this warranty are sales outside of the United States of America and Canada.

ICON Vehicle Dynamics' obligation under this warranty is limited to the repair or replacement, at ICON Vehicle Dynamics' discretion, of the defective product. Any and all costs of removal, installation or re-installation, freight charges and incidental or consequential damages are expressly excluded from this warranty. Items that are subject to wear are not considered defective when worn and are not covered.

ICON Vehicle Dynamics components must be installed as a complete kit as shown in our current application guide. Any substitutions or exemptions of required components will immediately void the warranty. Some finish damage may happen to parts during shipping and is not covered under warranty.

This warranty is expressly in lieu of all other warranties expressed or implied. This warranty shall not apply to any product that has been improperly installed, modified or customized subject to accident, negligence, abuse or misuse.

To send a shock in for warranty please visit our website <http://www.iconvehicledynamics.com/tech-support/shock-service/>



ICON VEHICLE DYNAMICS®
PERFORMANCE SUSPENSION SYSTEMS AND SHOCK ABSORBERS

7929 Lincoln Ave. Riverside, CA 92504 Phone: 951.689.ICON Fax: 951.689.1016
www.iconvehicledynamics.com



FOLLOW US ON FACEBOOK!



7929 Lincoln Ave. Riverside, CA 92504
Phone: 951.689.ICON | Fax: 951.689.1016

PART #	DESCRIPTION
58551DJ	07-UP FJ/03-UP 4RNR/03-UP GX BILLET UCA DJ KIT

COMPONENTS INCLUDED	
(1) 157515 03+ 4RUNNER BILLET UCA (DRIVER)	(1) 157516 03+ 4RUNNER BILLET UCA (PASS)
HARDWARE INCLUDED	
(2) 157517BJ DELTA JOINT	(1) 605968 VIBRATITE BLUE 2ML BULLET
HEIM SPACER KIT	
(4) 157502 HEIM SPACER JM12 X 14MM X 3.275	(4) 157503 HEIM SPACER JM12 X 14MM X 1.775
DUST COVER COMPONENTS KIT	
(2) 157507 BILLET UCA DUST COVER (8) 605002 6-32 X .50" SHCS 18-8	(2) 155110 -032 O-RING
TOOLS REQUIRED	
JACK JACK STANDS LARGE HAMMER TORQUE WRENCH NEEDLE NOSE PLIERS 7/64" ALLEN WRENCH	10MM SOCKET / WRENCH 19MM SOCKET / WRENCH 21MM SOCKET / WRENCH 3/8" SOCKET / WRENCH 1/2" SOCKET / WRENCH 7/8" SOCKET / WRENCH
TECH NOTES	
<p>1. ALL ICON UPPER CONTROL ARMS HAVE BEEN ENGINEERED TO ALLOW FOR THE MOST POSSIBLE CASTER, WHILE STILL ALLOWING THE VEHICLE TO BE PROPERLY ALIGNED. NOTIFY YOUR PROFESSIONAL ALIGNMENT SHOP OF THIS INFORMATION SO THAT MAXIMUM RIDE QUALITY CAN BE ACHIEVED.</p> <p>2. ICON DELTA JOINTS ARE PRE-GREASED FROM THE FACTORY. ICON RECOMMENDS GREASING THE DELTA JOINT EVERY 3,000 MILES (OR EVERY OIL CHANGE). ADD NEW GREASE UNTIL ALL OF THE OLD GREASE IS EXPELLED FROM THE BOTTOM OF THE DELTA JOINT ASSEMBLY, WIPE AWAY EXCESS WITH A RAG OR SHOP TOWEL.</p> <p>3. DO NOT EXCEED 1.875" ADJUSTMENT FROM THE CENTER OF THE ROD END TO THE EDGE OF THE BILLET UPPER CONTROL ARM. FAILURE CAUSED BY EXCESSIVE ADJUSTMENT WILL NOT BE COVERED UNDER ICON'S WARRANTY POLICY. REFER TO TECH NOTE PHOTO #2.</p> <p>4. KDSS EQUIPPED VEHICLES WILL REQUIRE THE SYSTEM TO BE DEACTIVATED BEFORE INSTALLATION, AND REACTIVATED AFTER INSTALLATION IS COMPLETE. REFER TO FACTORY SERVICE MANUAL FOR MORE INFORMATION.</p>	

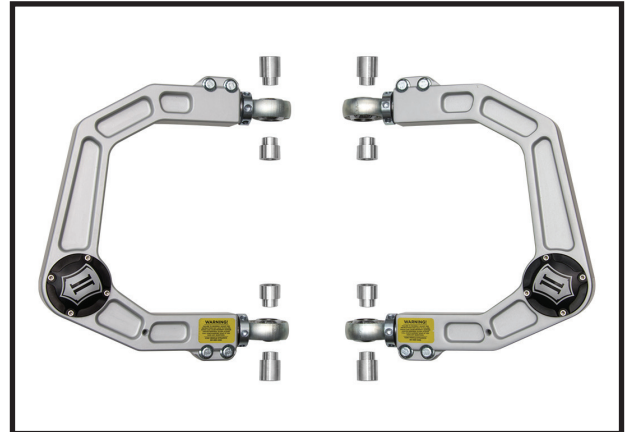

WARNING!
<p>** READ ALL INSTRUCTIONS THOROUGHLY FROM START TO FINISH BEFORE BEGINNING INSTALLATION! IF THESE INSTRUCTIONS ARE NOT PROPERLY FOLLOWED SEVERE FRAME, SUSPENSION AND TIRE DAMAGE MAY RESULT TO THE VEHICLE!</p> <p>** ICON VEHICLE DYNAMICS RECOMMENDS THAT YOU EXERCISE EXTREME CAUTION WHEN WORKING UNDER A VEHICLE THAT IS SUPPORTED WITH JACK STANDS.</p> <p>**ICON VEHICLE DYNAMICS RECOMMENDS ALL INSTALLATION TO BE PERFORMED BY A PROFESSIONAL SHOP/SERVICE TECHNICIAN. PRODUCT FAILURE CAUSED BY IMPROPER INSTALLATION WILL NOT BE COVERED UNDER ICON'S WARRANTY POLICY.</p>

INSTALLATION

1. If your vehicle is equipped with Kinetik Dynamic Suspension System (KDSS), deactivate the system before performing ANY work to the vehicle. Refer to the factory service manual for information on how to deactivate this system. KDSS will need to be reactivated once the installation is complete.
2. Using a properly rated jack, raise the front of the vehicle and support the frame rails with jack stands. Ensure the jack stands are secure and set properly before lowering the jack. NEVER WORK UNDER AN UNSUPPORTED VEHICLE. Remove front wheels.
3. Using a jack, slightly lift the lower control arm to prevent the suspension from being at full droop.
4. Disconnect the upper ball joint: remove the cotter pin securing the upper ball joint nut. Using a 19mm socket/wrench, loosen the nut to the end of the shank but do not remove entirely so that the nut protects the threads. Dislodge the taper by either using a ball joint separator or by striking the spindle on the outside of the taper with a large hammer or hand sledge.
5. Support the spindle so that it does not over extend the CV joints when detached.
6. Using a 10mm socket/wrench, disconnect the ABS line that is routed down the top of the arm. Remove the ball joint nut and disconnect the upper control arm from the spindle.
7. Using a 19mm socket/wrench, remove the large upper control arm pivot bolt. This hardware will be reused, note direction and order of components. Remove the nut and washer from the rear side of the long pivot bolt. Carefully feed the bolt forward until it clears the front of the A-arm. Remove the stock upper control arm.
8. Install the new billet upper control arm into the chassis: Note the side and orientation of the arms, the Delta Joint should be oriented to the back of the vehicle and the 4 small holes for the dust cover should be pointing up. Carefully feed the pivot bolt through the pivots of the arm, through the pivot tube in the chassis and secure with the factory hardware. [Torque to factory spec]
9. Pivot the Delta Joint stem so that it is in-line with the taper bore in the spindle. The new Delta Joint will be very stiff the first time you move it.
10. Rotate the upper control arm downward and install the stem through the spindle taper. Install the supplied flanged nut on the taper pin. [Torque to 75 ft-lbs]

- 11.** Using a 10mm socket/wrench reattach the ABS line to the threaded hole in the arm with the factory bolt.
- 12.** ICON billet upper control arms utilize heim joints at each pivot to allow alignment using the adjusters on the upper control arms as well as cam adjusters on the lower control arms. The heims can be extended or contracted by turning the adjustment collar. Make sure that the slit in the collar lines up with the slit in the housing and then tighten the pinch bolts in an opposing pattern at least 3 times. [Torque to 40 ft-lbs]
- 13.** Install wheels and lower vehicle back to the ground. [Torque to factory spec]
- 14.** Install the dust cover: Make sure that the o-ring is seated in the groove in the cap and apply anti-seize to the (4) allen head screws. DO NOT over tighten!
- 15.** Have the vehicle professionally aligned.
- 16.** Once aligned, apply BLUE thread locker to the outer pinch bolts located on the sides of the arm. Tighten the pinch bolts in an opposing pattern at least 3 times. [Torque to 35 ft-lbs]

ALIGNMENT NOTE

ICON SHIPS THE BILLET UPPER CONTROL ARM AT THE MOST COMMON ALIGNMENT SETTING. ONE OF THE MAJOR PERFORMANCE ADVANTAGES OF AN ICON BILLET ADJUSTABLE UPPER CONTROL ARM IS THE ABILITY TO IMPROVE WHEEL POSITION. IMPROVING WHEEL POSITION IMPROVES FIREWALL CLEARANCE ALLOWING FOR LARGER TIRES AS THE SUSPENSION CYCLES. IN ORDER TO TAKE ADVANTAGE OF THIS FEATURE, DISCUSS WITH YOUR PROFESSIONAL ALIGNMENT SHOP THAT YOU WOULD LIKE TO CAM THE LOWER CONTROL ARM TO MAXIMIZE WHEEL POSITION FORWARD AND THEN ADJUST CAMBER AND CASTER WITH THE UPPER THREADED ADJUSTERS.

A MAJOR PERFORMANCE ADVANTAGE OF ALL ICON UPPER CONTROL ARMS IS INCREASED CASTER OVER STOCK. DISCUSS WITH A PROFESSIONAL ALIGNMENT SHOP THAT YOU WANT THE VEHICLE ALIGNED WITH THE CASTER AT THE MAX OF THE FACTORY RECOMMENDED SETTINGS IF YOU WANT TO TAKE ADVANTAGE OF THE DYNAMIC EFFECTS OF INCREASED CASTER.

VERIFY ALL FASTENERS ARE PROPERLY TORQUED BEFORE DRIVING VEHICLE.

RETORQUE ALL NUTS, BOLTS AND LUGS AFTER 100 MILES AND PERIODICALLY THEREAFTER.



[TECH NOTE #2]



ICON VEHICLE DYNAMICS LIMITED LIFETIME WARRANTY

ICON Vehicle Dynamics warrants to the original retail purchaser who owns the vehicle on which the product was originally installed. ICON Vehicle Dynamics does not warrant the product for finish, alterations, modifications and/or installation contrary to ICON Vehicle Dynamics instructions. ICON Vehicle Dynamics products are not designed, nor are they intended to be installed on vehicles used in race applications, for racing purposes or for similar activities. (A "race" is defined as any contest between two or more vehicles, or a contest of one or more vehicles against the clock, whether or not such contest is for a prize). This warranty does not include coverage for police or taxi vehicles, race vehicles, or vehicles used for government or commercial purposes. Also excluded from this warranty are sales outside of the United States of America and Canada.

ICON Vehicle Dynamics' obligation under this warranty is limited to the repair or replacement, at ICON Vehicle Dynamics' discretion, of the defective product. Any and all costs of removal, installation or re-installation, freight charges and incidental or consequential damages are expressly excluded from this warranty. Items that are subject to wear are not considered defective when worn and are not covered.

ICON Vehicle Dynamics components must be installed as a complete kit as shown in our current application guide. Any substitutions or exemptions of required components will immediately void the warranty. Some finish damage may happen to parts during shipping and is not covered under warranty.

This warranty is expressly in lieu of all other warranties expressed or implied. This warranty shall not apply to any product that has been improperly installed, modified or customized subject to accident, negligence, abuse or misuse.



ICON VEHICLE DYNAMICS®
PERFORMANCE SUSPENSION SYSTEMS AND SHOCK ABSORBERS

7929 Lincoln Ave. Riverside, CA 92504 Phone: 951.689.ICON Fax: 951.689.1016
www.iconvehicledynamics.com



FOLLOW US ON FACEBOOK!



7929 Lincoln Ave. Riverside, CA 92504
 Phone: 951.689.ICON | Fax: 951.689.1016

PART #	DESCRIPTION
58647	10-UP FJ/4RNR/10-UP GX EXT TRAVEL 2.5 VS IR COILOVER KIT

COMPONENTS INCLUDED	
(2) 154953 07+ FJ/03+ 4RUNNER EXT TRAVEL IR (1) 611019 COILOVER HARDWARE KIT (PAIR)	(1) 611031 10-UP FJ/4RNR SWAYBAR RELOCATION KIT
HARDWARE INCLUDED	
611019 HARDWARE KIT	
(6) 605101 3/8-16 X 1.000 BOLT	(6) 605131 3/8" SPLIT LOCK WASHER
611031 HARDWARE KIT	
(2) 157110 10+ FJ SWAYBAR BRACKET (4) 605100 3/8-16 X .750 BOLT (4) 605133 3/8 FLAT WASHER	(14) 605432 9/16 WASHER THICK 1.18 X .585 X .18 (4) 605808 M10-1.25 X 25MM (2) 605853 M10-1.25 X 25MM FLANGED BOLT
TOOLS REQUIRED	
JACK JACK STANDS TORQUE WRENCH HAMMER 9/16" SOCKET / WRENCH 8MM ALLEN WRENCH	10MM SOCKET / WRENCH 13MM SOCKET / WRENCH 14MM SOCKET / WRENCH 15MM SOCKET / WRENCH 18MM SOCKET / WRENCH 21MM SOCKET / WRENCH
TECH NOTES	
<p>1. YOUR ICON COILOVER ASSEMBLIES COME FACTORY CHARGED TO 250 PSI. RELEASING NITROGEN PRESSURE MAY LEAD TO SHOCK MALFUNCTION AND REDUCED RIDE QUALITY. FAILURE CAUSED BY LOW NITROGEN PRESSURE IS NOT COVERED UNDER ICON'S WARRANTY POLICY.</p> <p>2. YOUR ICON COILOVER ASSEMBLIES COME SHIPPED AT ICON'S RECOMMENDED RIDE HEIGHT. DO NOT PRELOAD THE COIL BEYOND 2.13" (1.13" FOR 700LB COIL #158508) OF EXPOSED THREADS BETWEEN THE BOTTOM OF THE TOP CAP AND THE TOP OF THE COIL ADJUSTER NUT. A REDUCTION IN RIDE QUALITY WILL BE EXPERIENCED IF COILOVERS ARE ADJUSTED TO ALLOW FOR LESS THAN 2" OF DROOP TRAVEL FROM STATIC RIDE HEIGHT.</p> <p>3. REQUIRES USE OF ICON TUBULAR UPPER CONTROL ARM (58451) OR ICON BILLET UPPER CONTROL ARM (58551).</p> <p>4. KDSS EQUIPPED VEHICLES WILL REQUIRE THE SYSTEM TO BE DEACTIVATED BEFORE INSTALLATION, AND REACTIVATED AFTER INSTALLATION IS COMPLETE. REFER TO FACTORY SERVICE MANUAL FOR MORE INFORMATION.</p> <p>5. KDSS EQUIPPED VEHICLES WILL NOT USE SWAYBAR RELOCATION KIT (611031).</p>	



WARNING!
<p>** READ ALL INSTRUCTIONS THOROUGHLY FROM START TO FINISH BEFORE BEGINNING INSTALLATION! IF THESE INSTRUCTIONS ARE NOT PROPERLY FOLLOWED SEVERE FRAME, SUSPENSION AND TIRE DAMAGE MAY RESULT TO THE VEHICLE!</p> <p>** ICON VEHICLE DYNAMICS RECOMMENDS THAT YOU EXERCISE EXTREME CAUTION WHEN WORKING UNDER A VEHICLE THAT IS SUPPORTED WITH JACK STANDS.</p> <p>**ICON VEHICLE DYNAMICS RECOMMENDS ALL INSTALLATION TO BE PERFORMED BY A PROFESSIONAL SHOP/SERVICE TECHNICIAN. PRODUCT FAILURE CAUSED BY IMPROPER INSTALLATION WILL NOT BE COVERED UNDER ICON'S WARRANTY POLICY.</p>

INSTALLATION

1. If your vehicle is equipped with Kinetik Dynamic Suspension System (KDSS), deactivate the system before performing ANY work to the vehicle. Refer to the factory service manual for information on how to deactivate this system. KDSS will need to be reactivated once the installation is complete.
2. Using a properly rated jack, raise the front of the vehicle and support the frame rails with jack stands. Ensure the jack stands are secure and set properly before lowering the jack. NEVER WORK UNDER AN UNSUPPORTED VEHICLE. Remove the front wheels.
3. Remove the plastic upper skid plate using a 10mm and a flat head screwdriver. Remove the lower skid plate using a 12mm. Remove the skid plate braces using a 15mm. [FIGURE 1 - 3]

FIG.1



FIG.2



FIG.3



- 4.** Disconnect the outer tie rod end on both sides. Remove the cotter pin and loosen the nut until it is flush with the end of the threads. Strike the end of the steering knuckle arm with a large hammer to dislodge the taper. Remove the nut and swing the tie rod out of the way.
- 5.** Disconnect the sway bar from the frame on both sides. Remove bolts using a 14mm socket/wrench and remove the bracket from the sway bar. Move the sway bar forward to make room for removal and installation of the shock.
- 6.** To make room for removal of the factory coilover assembly, disconnect the knuckle from the upper control arm. Once the knuckle is disconnected from the upper control arm, support the knuckle so that brake line damage does not occur.
- 7.** Support the lower control arm with a jack and remove the (3) nuts securing the upper shock assembly mount to the coil bucket. Do not loosen or remove the large center nut securing the spring seat to the shock shaft. Failure to comply will result in the stock coil assembly to come apart violently, causing damage to components and possible injury.
- 8.** Loosen the bolt connecting the shock to the lower control arm. Lower jack and remove the bolt. Note orientation; as this bolt will be reused. The head of the bolt should be facing forward.
- 9.** Remove the stock coil assembly. Due to rubber bushing stiffness you may need to pull down on the suspension. Be careful not to damage any brake lines or wires that may be routed down the upper control arm.
- 10.** Install lower shock mount to lower control arm: The lower shock mount has (1) long and (1) short spacer. Make sure the long spacer is toward the front of the vehicle. This will position the shock further toward the rear of the lower control arm to ensure adequate sway bar clearance. Reinstall the factory lower shock bolt. [Torque to factory spec] **[FIGURE 4]**

FIG.4



- 11.** If replacing the upper control arms, refer to appropriate UCA instructions now. Mount the upper control arm to the knuckle and tighten the taper nut. [Torque to factory spec]
- 12.** Reinstall the outer tie rod end [Torque to factory spec] and install cotter pin.
- 13.** Remove the factory skid plate using a 14mm socket/wrench and set aside.
- 14.** Install the sway bar relocation block (157110). Using the factory hardware, bolt the block to the frame [Torque to factory spec]. The heads will be recessed in the block. Make sure the block is positioned so that the new threaded holes are forward of the countersunk holes. Using the supplied (605100) bolts, (605133) washers and factory U-clamp, reinstall the sway bar in it's new position, forward of factory location. **[FIGURE 5]**

FIG.5



15. Install the skid plate braces with the supplied skid plate washers (605432) between the frame and skid plate on all six mounting locations. Use (2) washers per bolt with (3) washers on the bolts towards the front of the truck. Use the supplied (605853) hardware for the middle bolts that go into the protruding bung and the factory hardware for the remaining mounting locations and tighten with a 14mm socket/wrench. [Torque to factory spec] [FIGURE 6]

FIG.6

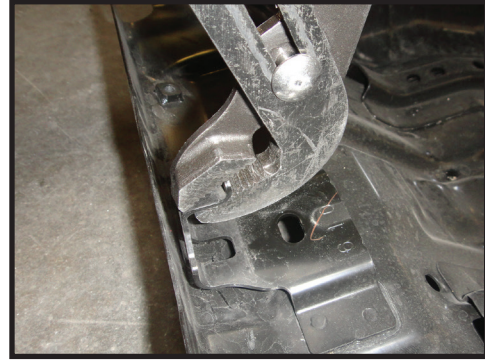

FIG.7

16. Slightly bend the hanger tabs down on the factory skid plate, they will no longer be used. [FIGURE 7]

17. Install the OEM skid plate using the factory hardware and a 12mm. [FIGURE 8 & 9]

FIG.8

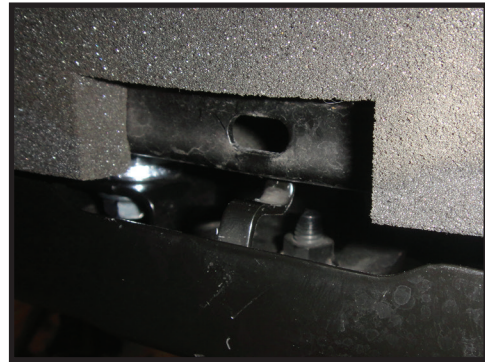

FIG.9

18. Install the plastic upper skid plate using the factory hardware and a 10mm. [FIGURE 10]

FIG.10



19. Install wheels and lower vehicle back to the ground. [Torque lugs to factory spec]

20. Have the vehicle professionally aligned.

FOR KDSS EQUIPPED VEHICLES: After completing installation of ICON components, refer to factory Toyota service manual to reset the KDSS system.

VERIFY ALL FASTENERS ARE PROPERLY TORQUED BEFORE DRIVING VEHICLE.

RETORQUE ALL NUTS, BOLTS AND LUGS AFTER 100 MILES AND PERIODICALLY THEREAFTER.

2.5 VS SERIES SHOCK & COILOVER TECHNICAL INFORMATION

MAINTENANCE

ICON shock absorbers are a high quality rebuildable race style shock absorber designed for optimal performance. With a unit of this caliber on your vehicle, routine maintenance is required to keep them looking and operating in like new condition. Residual oil and assembly lube may be present at all seal paths from the factory out of the box and is considered normal. Pooling of oil however is not acceptable at any time and one should contact the ICON dealer where purchased.

BELOW ARE GUIDELINES BASED ON HOW YOU USE YOUR VEHICLE BUT YOUR MILEAGE MAY VARY:

STREET USE:

- Send in for factory servicing every 40,000 miles or if a leak develops, ride quality decreases, or they begin to make excessive noise.
- Remove any buildup of road salt, mud, or debris from shocks and coil springs anytime accrued
- Clean with mild soap and water with each oil change or anytime you notice build up.
- Wax the cylinders yearly with automotive wax to prevent corrosion.
- Check nitrogen pressure yearly. (252004 charge needle assembly available at any ICON distributor)
- Check bearings for excessive wear yearly.
- DO NOT apply any type of lube to the upper and lower bearings.

STREET/DIRT:

- Send in for factory servicing every 15,000 miles or if a leak develops, ride quality decreases, or they begin to make excessive noise.
- Clean with mild soap and water with each oil change, offroad trip, or anytime you notice build up.
- Wax the cylinders yearly with automotive wax to prevent corrosion.
- Check nitrogen pressure each dirt outing. (252004 charge needle assembly available at any ICON distributor)
- Check bearings for excessive wear yearly.
- DO NOT apply any type of lube to the upper and lower bearings.

DIRT USE:

- Send in for factory servicing every 1,000 miles.
- Check nitrogen pressure each outing. (252004 charge needle assembly available at any ICON distributor)
- Remove any buildup of mud or debris from shocks and coil springs after every outing.

SELF-SERVICE:

- Contact ICON for service kits & tools at (951) 689-4266.

PRODUCT REGISTRATION

Please visit: <http://www.iconvehicledynamics.com/tech-support/registration/> to register your product.

ICON VEHICLE DYNAMICS SHOCK ABSORBER WARRANTY

This shock absorber has a 1 year warranty against any manufacturer's defects. If a shock fails within the initial year of ownership, the shock must be shipped to ICON Vehicle Dynamics for inspection and service. If a shock is inspected and it has been determined the shock failed due to neglect, damage caused by improper installation or any other reason besides "normal wear and tear", the owner of said shock is responsible for all service costs. This includes labor, parts, and shipping.

ICON Vehicle Dynamics warrants to the original retail purchaser who owns the vehicle on which the product was originally installed. ICON Vehicle Dynamics does not warrant the product for finish, alterations, modifications and/or installation contrary to ICON Vehicle Dynamics instructions. ICON Vehicle Dynamics products are not designed, nor are they intended to be installed on vehicles used in race applications, for racing purposes or for similar activities. (A "race" is defined as any contest between two or more vehicles, or a contest of one or more vehicles against the clock, whether or not such contest is for a prize). This warranty does not include coverage for police or taxi vehicles, race vehicles, or vehicles used for government or commercial purposes. Also excluded from this warranty are sales outside of the United States of America and Canada.

ICON Vehicle Dynamics' obligation under this warranty is limited to the repair or replacement, at ICON Vehicle Dynamics' discretion, of the defective product. Any and all costs of removal, installation or re-installation, freight charges and incidental or consequential damages are expressly excluded from this warranty. Items that are subject to wear are not considered defective when worn and are not covered.

ICON Vehicle Dynamics components must be installed as a complete kit as shown in our current application guide. Any substitutions or exemptions of required components will immediately void the warranty. Some finish damage may happen to parts during shipping and is not covered under warranty.

This warranty is expressly in lieu of all other warranties expressed or implied. This warranty shall not apply to any product that has been improperly installed, modified or customized subject to accident, negligence, abuse or misuse.

To send a shock in for warranty please visit our website <http://www.iconvehicledynamics.com/tech-support/shock-service/>



ICON VEHICLE DYNAMICS®
PERFORMANCE SUSPENSION SYSTEMS AND SHOCK ABSORBERS

7929 Lincoln Ave. Riverside, CA 92504 Phone: 951.689.ICON Fax: 951.689.1016
www.iconvehicledynamics.com



FOLLOW US ON FACEBOOK!

