



[05.06.25]

TOYOTA 4-RUNNER 2WD/4WD 2015.5-2024 PERFORMANCE SPINDLE KIT PART# CAM-310222

[980088]

Always inspect your suspension after off-roading and at your routine service intervals. Use of products sold by Camburg Engineering is at the consumer's own risk. Proper installation and proper use of all products must be followed for optimal safety and performance. Installing most suspension products will raise the center of gravity of the vehicle and can increase the susceptibility to a rollover and alter the handling characteristics. Camburg Engineering products may void aspects of the vehicles warranty. Camburg Engineering reserves the right to change the design, material or specifications of any product without assuming any obligation to modify any product previously manufactured and without prior notice. Every effort has been made to avoid printing errors and specifications. By purchasing, installing and/or using these products you are accepting these stated conditions and accept all liability and responsibility.

Thanks for purchasing our performance spindles for your Toyota 4-Runner. If you are not installing these yourself have a qualified shop do so. These spindles were designed to replace the OEM versions and work with parts associated with them. Check the parts list to make sure you have every component prior to installing. Camburg Engineering has made every attempt to insure you receive the highest quality components in the most complete manner. This is a guide to help you through the process with some recommended torque specs & notes. It's your responsibility to ensure parts are being installed correctly using the correct tools and procedures to the proper torque. For step-by-step instructions refer to a Toyota service/repair manual.

PART NBR	DESCRIPTION	QTY
	DRIVER SIDE SPINDLE	1
	PASSENGER SIDE SPINDLE	1
330027	STOCK LENGTH STAINLESS BRAIDED FRONT BRAKE LINE KIT	1
950093	14" TY-28MX ZIP TIE (BLACK)	4
030017	CAMBURG 8.5" STICKER	4

IMPORTANT - 2015 4-Runner's Only:

These fit 2015.5 4-Runners with the larger M14 brake caliper bolts (19mm hex head), verify size prior to installing. Use CAM-310114 spindles if your 2015 has the smaller M12 brake caliper bolts. This is due to a mid-year production change Toyota made.

Important Notes:

- Re-use the existing M16 bolts with the OEM lower ball-joint cradle or our long-travel uniball adapter. When using these with other kits, make sure your M16 bolts are not too short/long.
- The front sway-bar assembly will not be re-used (non-KDSS).
- The front brake rotor dust shields will not be re-used.
- When running larger than stock tires we recommend a zero offset wheel (4.50-4.75" backspacing) for added clearance.
- Stock wheels and tires fit correctly "as is".
- Use RED loctite on all fasteners > 1/4" dia.
- Use BLUE loctite on all fasteners < 1/4" dia.
- On older or higher mileage 4wd vehicles we recommend replacing the inner hub seals.
- Inspect and re-torque all hardware and components after the first 500 miles, inspect at your scheduled maintenance intervals and whenever using the vehicle off-road.

Recommended Torque Specs:

- M16 Lower BJ Cradle or Uniball Adapter Bolts = 160 ft/lbs.
- Hub Unit Bolts = 60 ft/lbs.
- 4wd Axle Shaft Hub Nut = 175 ft/lbs.
- Brake Caliper Bolts = 137 ft/lbs.
- Outer Tie Rod Castle Nut = 68 ft/lbs.
- Ball-joint Upper Arm Castle Nut = 82 ft/lbs.
- Uniball Upper Arm Nut = 125 ft/lbs.

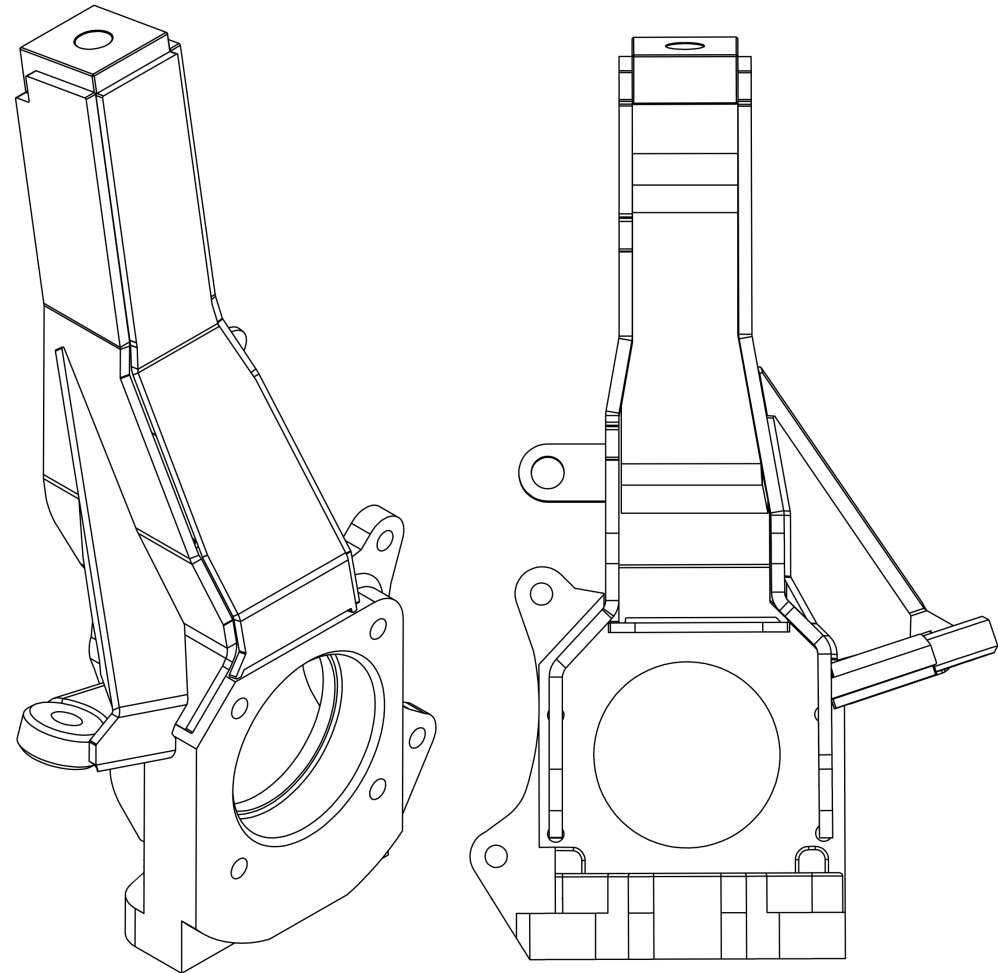

[DRIVER-SIDES SHOWN]



Warranty Information
Scan or Click QR Code