

PARTS LIST: TR14362

1	CS-1 "LD" Front Bumper	6	10mm x 30mm x 2.5mm Large Flat Washers
1	Driver/left Bumper Mounting Bracket	6	10mm x 20mm x 2mm Small Flat Washers
1	Passenger/right Bumper Mounting Bracket	12	10mm Lock Washers
1	Center Mesh Fill Panel	6	10mm Hex Nuts
1	Driver/left Mesh Fill Panel	6	8-1.25mm x 25mm Hex Bolts
1	Passenger/right Mesh Fill Panel	2	8-1.25mm x 16mm Hex Bolts
1	Driver/left "L" Top Light Bracket	14	8mm x 24mm x 2mm Flat Washers
1	Passenger/right "L" Top Light Bracket	8	8mm Lock Washers
2	Center LED "L" Brackets	6	8mm Hex Nuts
2	Plastic Plugs for License Plate	10	6mm x 20mm Button Head Combo Bolts
2	10mm x 143.5mm U-Bolts	2	6mm Flange Nuts
2	10mm x 35mm Bolt Plates	10	Nylon Wire Ties
6	10mm Plastic Retainers	1	1.7m Edge Trim
6	10-1.5mm x 30mm Hex Bolts	1	4mm Wrench

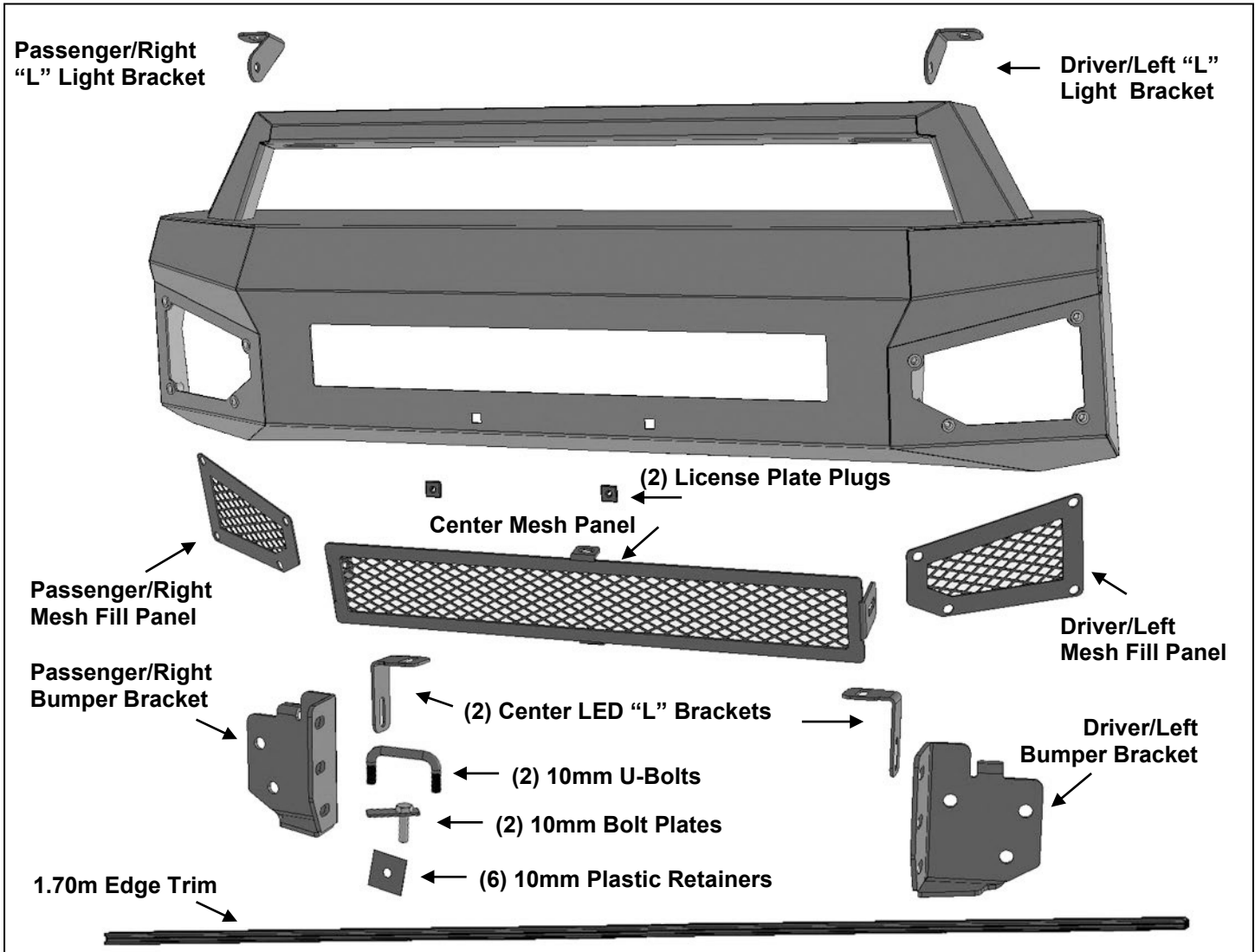

**CS-1 LD FRONT BUMPER
2014-22 TOYOTA 4RUNNER**

(EXCLUDES “LIMITED”, “NIGHTSHADE” AND 22 “TRD SPORT” MODELS)

PROCEDURE:

REMOVE CONTENTS FROM BOX. VERIFY ALL PARTS ARE PRESENT. READ INSTRUCTIONS CAREFULLY BEFORE STARTING INSTALLATION. ASSISTANCE IS HIGHLY RECOMMENDED TO AVOID POSSIBLE INJURY OR DAMAGE TO THE VEHICLE. CUTTING IS REQUIRED.

1. Remove the license plate and bracket from the bumper cover.
2. Remove the hardware attaching the plastic bumper cover along the bottom, **(Figure 1)**, and ends along the wheel openings, **(Figure 2)**.
3. Pull the fender liner back. On models with factory fog lights, unplug and move the wiring harness leading to the front bumper.
4. Open the hood and remove the plastic cover from the top of the radiator and grille, **(Figure 3)**.
5. Remove the hardware attaching the plastic bumper cover at the top. With assistance, pop the ends off of the inner clips and pull the bumper off and away from the vehicle, **(Figure 4)**. Move bumper cover to a soft, clean surface.
6. Remove the pad from the aluminum impact bumper, **(Figure 4)**.
7. Select (1) 10mm U-Bolt and (2) 10mm Plastic Retainers. Insert one end of the U-Bolt into the outer top hole and back through the inner top hole in the driver/left side of the aluminum impact bumper, **(Figures 5 & 6)**. Thread the Plastic Retainers onto the U-Bolt to help hold the U-Bolt in place. Next, insert (1) 10mm Bolt Plate into the lower hole in the aluminum bumper. Thread (1) Plastic Retainer onto the Bolt Plate. **NOTE:** Plastic Retainers have been provided to help with Mounting Bracket installation, use is not mandatory.
8. Select the driver/left Mounting Bracket, **(Figure 7)**. Attach the Bracket to the U-Bolt and Bolt Plate with (3) 10mm x 30mm Flat Washers, (3) 10mm Lock Washers and (3) 10mm Hex Nuts. Do not fully tighten hardware at this time.
9. Repeat Steps 7 & 8 to attach the passenger/right Mounting Bracket, **(Figure 8)**.
10. Move to the bumper cover assembly. On the back of the driver/left side of the bumper cover, locate the point where the vertical ridge molded into the side of the bumper cover ends, approximately 2-3/4" below the outer corner of the grille, **(Figure 9)**. Place a mark at this point. Locate the matching point on the passenger/right side of the bumper and mark the point below the grille. Use removable tape (masking tape for example) or a sharp marking pen and straight edge to draw a straight reference line from point to point across the back of the cover, **(Figures 10, 11 & 13)**. Draw a parallel line 1-3/8" above the reference line. This will be the upper cut line.
11. Locate the vertical molded ridge/bend on the back of the bumper, **(Figure 12)**. Start at the bottom of the bumper and draw a cut line along the top of the ridge/bend to the end, **(Figures 12 & 13)**. **NOTE:** Draw a connecting cut line between the reference line and top cut line approximately 3/8" in from corner bend to leave a lip to attach the Trim Strip, **(Figures 12 & 13)**.
12. Remove the (2) plastic mounts from the center of the bumper cover below the grille, **(Figure 13)**.
13. Use a sharp knife or hacksaw blade to cut out bumper cover along the cut line.
14. Reinstall the cut plastic bumper cover. Check the fit of the cover to the Bumper and trim cover as necessary for best fit. Once all trimming is completed, cover the cut edge of the bumper cover with the included Edge Trim, **(Figure 14)**. Cut the Edge Trim to fit as required. Reattach the fog light wiring harness at this time.
15. Determine if LED bar style light, (light not included), or Mesh Fill Panel will be installed in center opening in Bumper.
Center LED light installation, (sold separately).
 - a. Select the (1) Inner "L" Light Bracket, **(Figure 15)**. Use the provided (1) 8mm x 25mm Hex Bolt, (2) 8mm Flat Washers, (1) 8mm Lock Washer and (1) 8mm Hex Nut to attach the "L" Bracket to the mounting slot on the back of the Bumper. Leave hardware loose. Repeat to install the passenger/right Bracket.
 - b. Attach the LED light assembly to the "L" Brackets.
 - c. Adjust the light as necessary and tighten hardware.
 - d. Follow the instructions included with the light to connect the wire harness to the vehicle.

Center Mesh Fill Panel Installation. NOTE: Attach Center Panel before installing Bumper.

**CS-1 LD FRONT BUMPER
2014-22 TOYOTA 4RUNNER**

(EXCLUDES “LIMITED”, “NIGHTSHADE” AND 22 “TRD SPORT” MODELS)

- a. Repeat the previous Steps to install the Inner “L” Brackets, **(Figure 15)**.
 - b. Attach the Mesh Fill Panel to the Inner “L” Brackets with (2) 8mm x 25mm Hex Bolts, (4) 8mm Flat Washers, (2) 8mm Lock Washers and (2) 8mm Hex Nuts, **(Figure 16)**.
 - c. Attach center of Panel to top and bottom tabs on Bumper with the included (2) 6mm x 20mm Button Head Combo Bolts and (2) 6mm Flange Nuts, **(Figure 16)**.
 - d. Push Panel up against back of Bumper and tighten hardware.
- 16.** With assistance, position the mounting tabs on the back of the Bumper up to the inside of the Frame Brackets. Temporarily support Bumper. **WARNING:** To avoid possible injury or damage to the vehicle, do not proceed until the bumper is fully and safely supported.
- 17.** Attach the driver/left side of the Bumper to the inside of the Mounting Bracket with (3) 10mm X 30mm Hex Bolts, (3) 10mm Lock Washers and (3) 10mm x 20mm Small Flat Washers, **(Figures 17 & 18)**. Do not fully tighten hardware. Repeat this **Step** to attach the passenger/right side of the Bumper to the Mounting Bracket.
- 18.** Level and adjust the CS1 Bumper and fully tighten all hardware.
- 19.** Determine if accessory light, (not included), will be installed on the Bumper Hoop.
- a. Select the driver/left Top Light Bracket. Attach the Bracket to the slot on the back of the Bumper Hoop with (1) 8mm x 25mm Hex Bolt, (2) 8mm Flat Washers, (1) 8mm Lock Washer and (1) 8mm Hex Nut, **(Figure 19)**. Do not tighten hardware at this time.
 - b. Repeat previous **Step** to attach the passenger/right Bracket.
 - c. Select the 20” light, (not included). Attach the light to the Top Light Brackets with the hardware included with the light or the supplied (2) 8mm x 16mm Hex Bolts, (2) 8mm Lock Washers and (2) 8mm Flat Washers, **(Figure 19)**. Adjust and fully tighten light and Bracket hardware.
- 20.** Attach the outer Mesh Fill Panels to the Bumper with the included (8) 6mm Combo Bolts, **(Figure 20)**.
- 21.** Use the included (2) push-in Plastic Plugs to attach the front license plate, (if required), to the (2) holes in the front of the Bumper, **(Figure 20)**.
- 22.** Do periodic inspections to the installation to make sure that all hardware is secure and tight.

To protect your investment, Do not use any type of polish or wax that may contain abrasives that could damage the finish. Mild soap may be used to clean the Front Bumper assembly.



(Fig 1) Remove hardware attaching bottom of plastic bumper cover

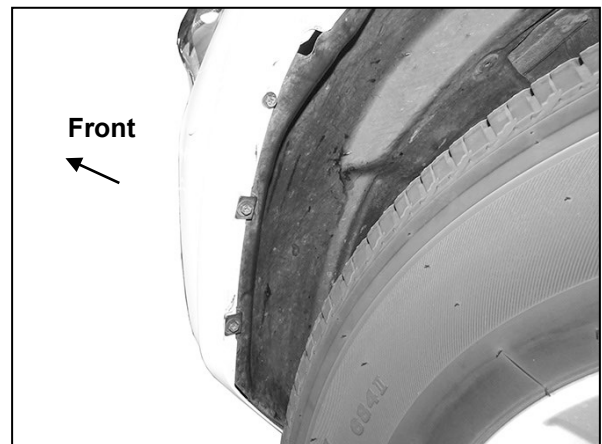

(Fig 2) Remove hardware attaching ends of plastic bumper cover along wheel openings

**CS-1 LD FRONT BUMPER
2014-22 TOYOTA 4RUNNER
(EXCLUDES "LIMITED", "NIGHTSHADE" AND 22 "TRD SPORT" MODELS)**

Driver/left Side Installation Pictured



(Fig 3) Remove cover (arrow)

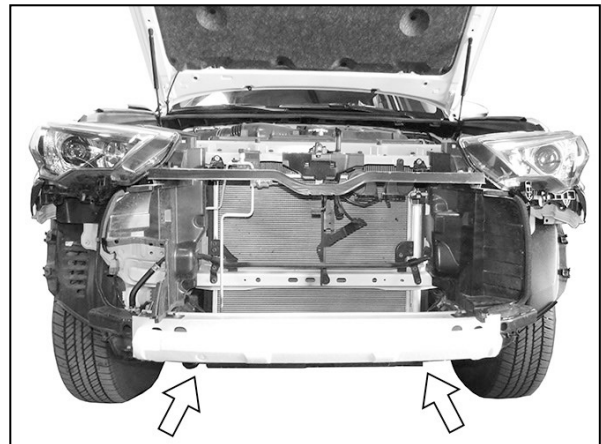

**(Fig 4) Remove plastic bumper cover.
Remove inner impact pad (arrows)**

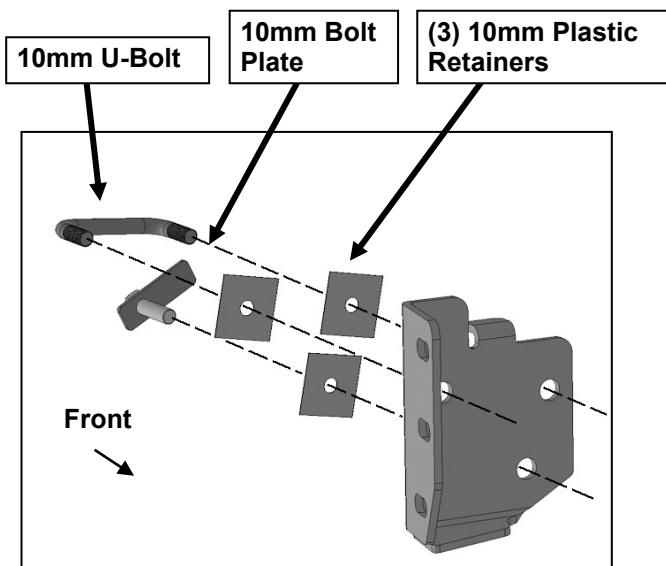

(Fig 5) Insert 10mm U-Bolt into the top holes in aluminum impact bumper. Insert 10mm Bolt Plate into bottom hole. Thread Plastic Retainers onto U-Bolt and Bolt Plate to hold in place (Retainer use is not mandatory)

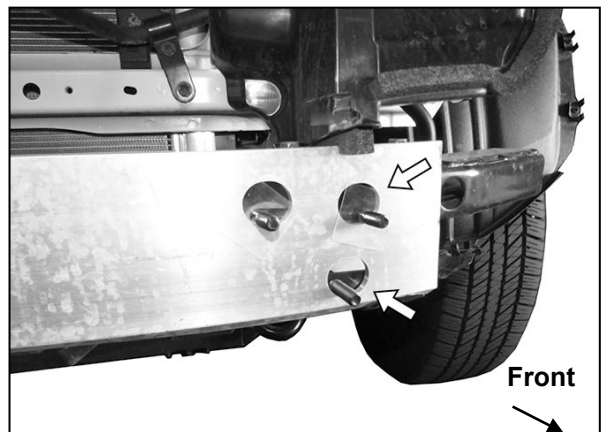

(Fig 6) Thread Plastic Retainers onto U-Bolt (top) and Bolt Plate (bottom) to help hold in place (arrows-Retainer use is optional)

**CS-1 LD FRONT BUMPER
2014-22 TOYOTA 4RUNNER
(EXCLUDES "LIMITED", "NIGHTSHADE" AND 22 "TRD SPORT" MODELS)**

Driver/left Side Installation Pictured

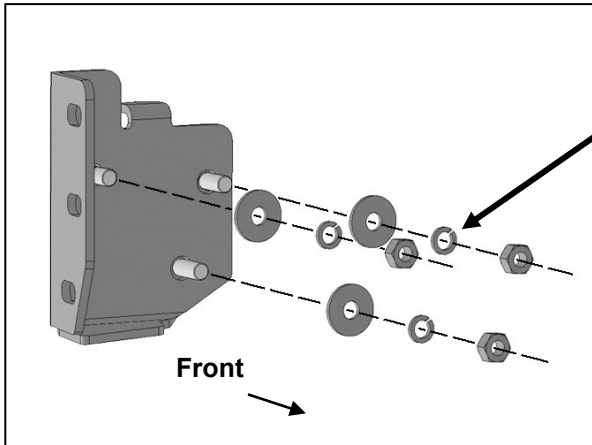

- (3) 10mm x 30mm Large Flat Washers
- (3) 10mm Lock Washers
- (3) 10mm Hex Nuts

(Fig 7) Attach driver/left Mounting Bracket to front of aluminum impact bumper

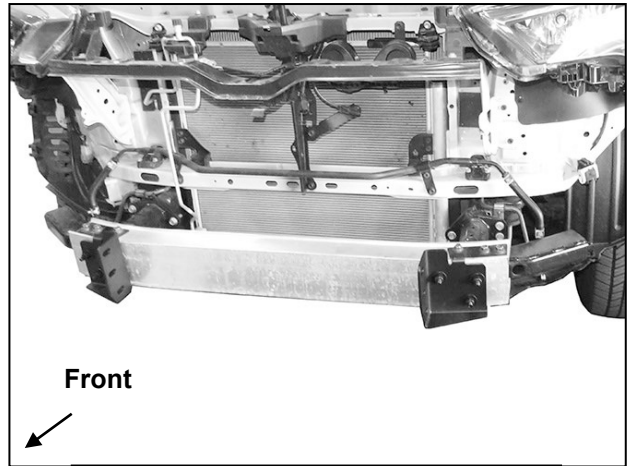

(Fig 8) Mounting Brackets installed

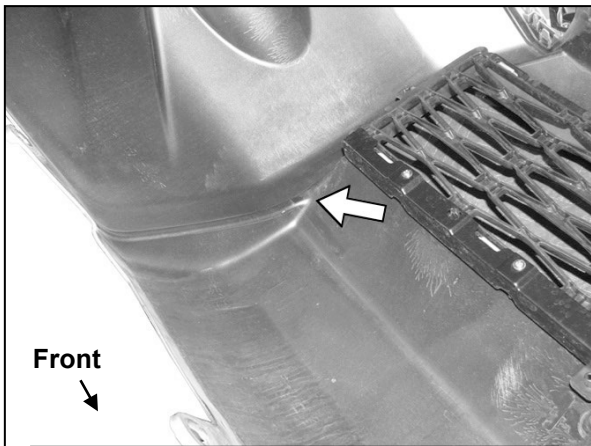

(Fig 9) Locate end of bend line (arrow) on back of plastic bumper cover (driver/left side pictured)

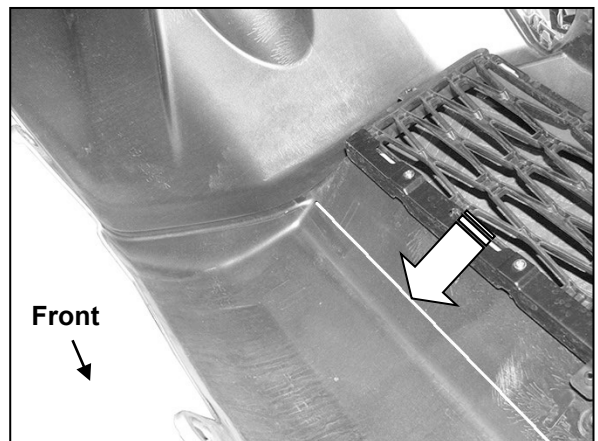

(Fig 10) Draw a reference line across the back of the cover connecting the two points pictured in Fig 11 (driver/left side pictured)

**CS-1 LD FRONT BUMPER
2014-22 TOYOTA 4RUNNER
(EXCLUDES "LIMITED", "NIGHTSHADE" AND 22 "TRD SPORT" MODELS)**

Driver/left Side Installation Pictured

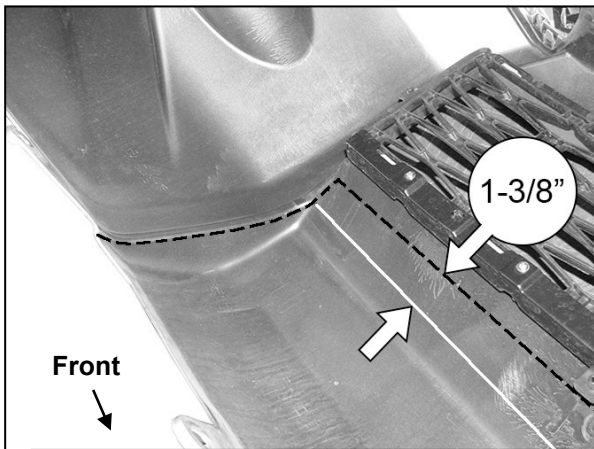

(Fig 11) Draw a cut line 1-3/8" above the reference line (driver/left side pictured)

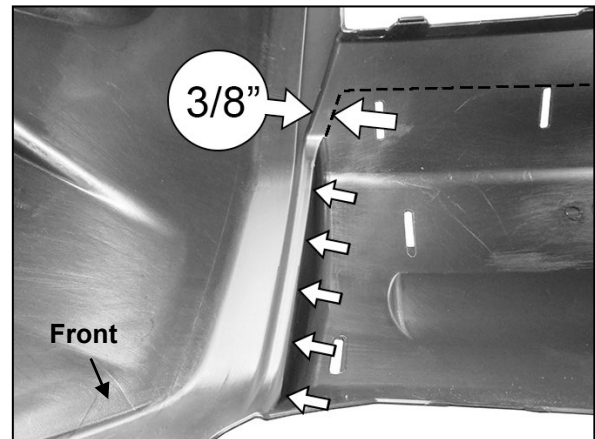

(Fig 12) Draw an upward line following the bend line (arrows) and up to the horizontal cut line (Fig 13). NOTE: Mark top of line 3/8" in from bend in cover to attach Edge Trim

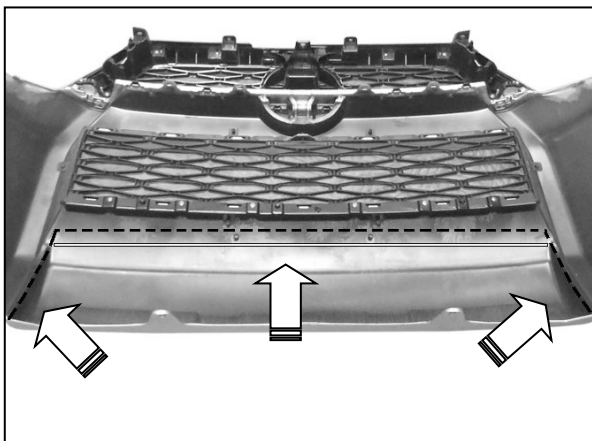

(Fig 13) Cut bumper cover along dashed line

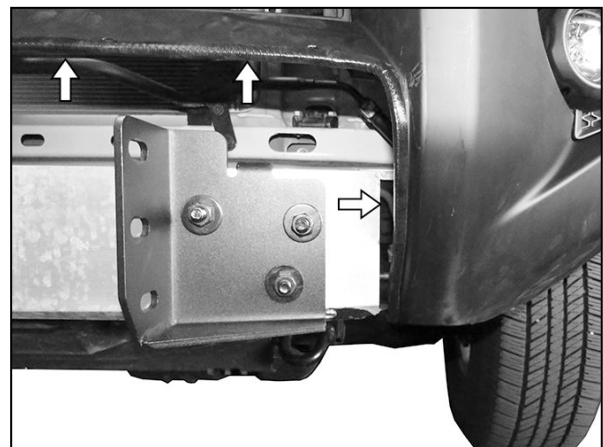

(Fig 14) Push Edge Trim onto cover (arrows). Cut Edge Trim to fit

**CS-1 LD FRONT BUMPER
2014-22 TOYOTA 4RUNNER
(EXCLUDES "LIMITED", "NIGHTSHADE" AND 22 "TRD SPORT" MODELS)**

Driver/left Side Installation Pictured

- 8mm x 25mm Hex Bolt
- (2) 8mm Flat Washers
- 8mm Lock Washer
- 8mm Hex Nut

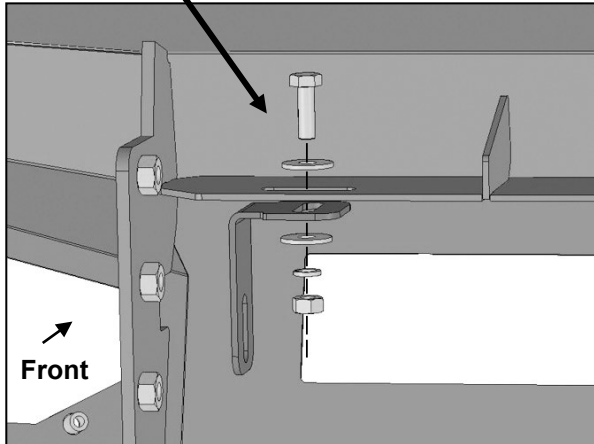

(Fig 15) Attach "L" Brackets to slots on back of Bumper. Attach light (not included), or Mesh Panel to "L" Brackets

- 8mm x 25mm Hex Bolt
- (2) 8mm Flat Washers
- 8mm Lock Washer
- 8mm Hex Nut

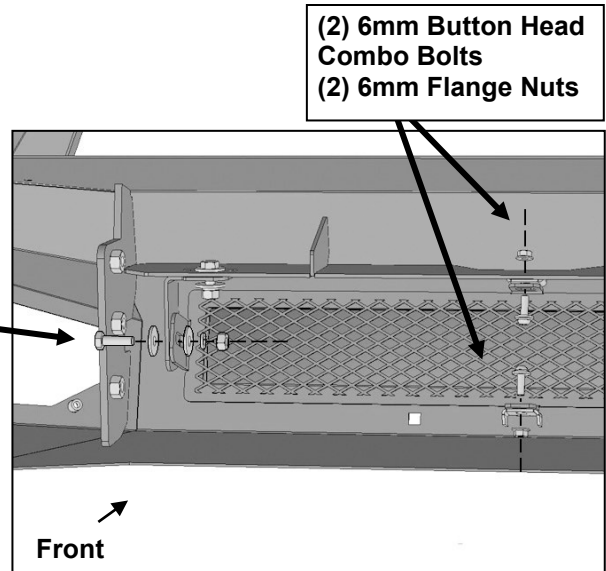

- (2) 6mm Button Head Combo Bolts
- (2) 6mm Flange Nuts

(Fig 16) Attach Mesh Panel to "L" Brackets and center tabs on back of Bumper

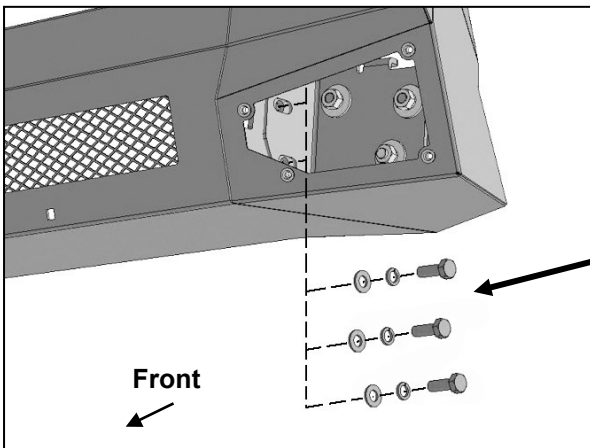

- (3) 10mm x 30mm Hex Bolts
- (3) 10mm Lock Washers
- (3) 10mm x 20mm Small Flat Washers

(Fig 17) Attach driver/left side of Bumper to inside of Mounting Bracket

**CS-1 LD FRONT BUMPER
2014-22 TOYOTA 4RUNNER
(EXCLUDES "LIMITED", "NIGHTSHADE" AND 22 "TRD SPORT" MODELS)**

Driver/left Side Installation Pictured

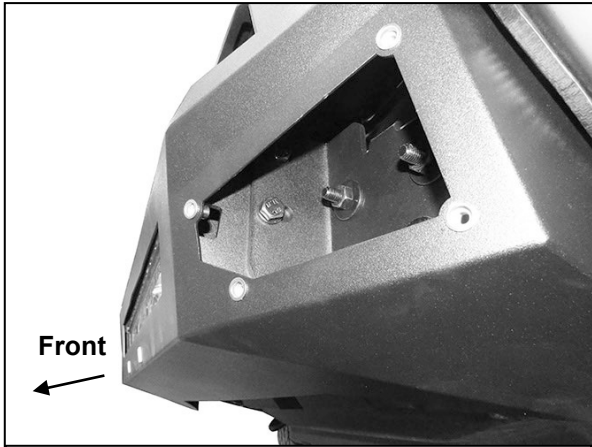

(Fig 18) Driver/left side of Bumper installed

- 8mm x 16mm Hex Bolt
8mm Lock Washer
8mm Flat Washer**
- 8mm x 25mm Hex Bolt
(2) 8mm Flat Washers
8mm Lock Washer
8mm Hex Nut**

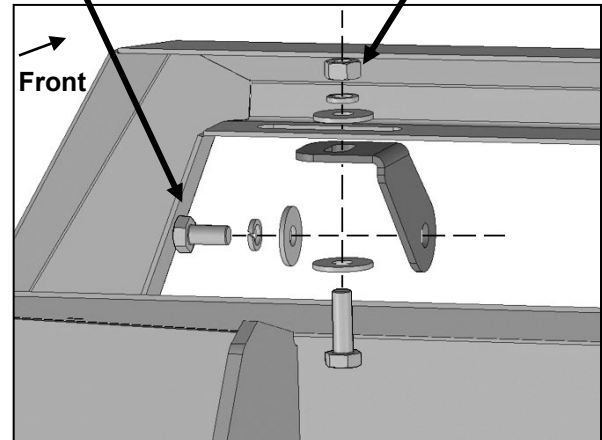

(Fig 19) Driver/left Top Light Bracket installed

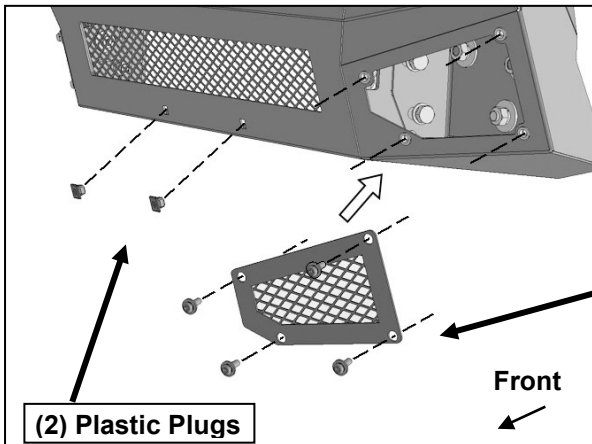

(2) Plastic Plugs
(Fig 20) Attach Outer Fill Panels to Bumper. Push Plastic Plugs into square holes in Bumper for license plate

- (4) 6mm x 20mm
Combo Bolts**



**Complete installation
(light (not included))**