



**BLACK HORSE
OFF ROAD**

TEL: 1-866-XANATOS

INSTALLATION INSTRUCTIONS

**3" BEACON BULL BAR
05-21 NISSAN FRONTIER
05-07 NISSAN PATHFINDER
05-15 NISSAN XTERRA
PART#BE-NIFRB**

PARTS LIST:

1	Bull Bar	4	12-1.75mm x 35mm Coarse Thread Hex Bolts
1	Driver/Left Side Mounting Bracket	8	12mm Lock Washers
1	Passenger/Right Side Mounting Bracket	4	12mm Hex Nuts
4	12-1.25mm x 35mm Fine Thread Hex Bolts (use for mounting brackets to frame only)	12	12mm ID x 37mm OD x 3mm Flat Washers

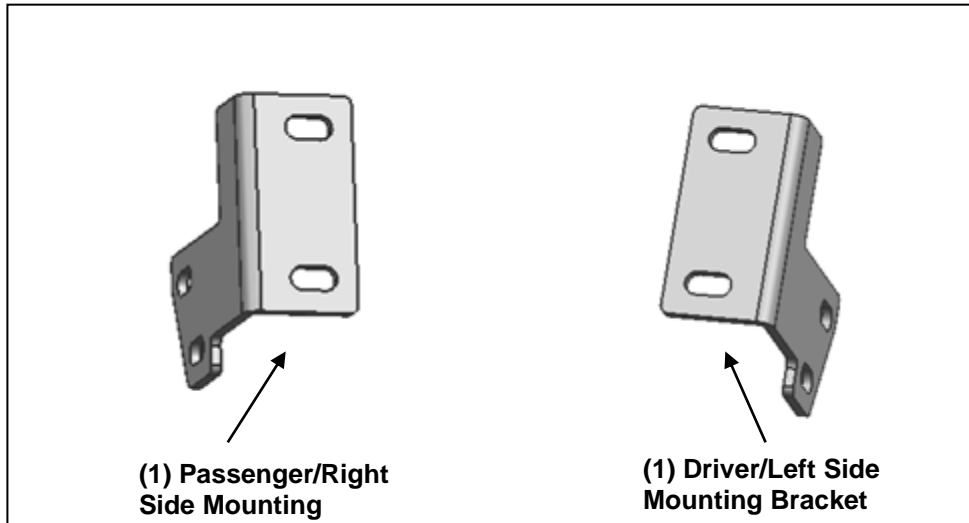
**PROCEDURE:**

1. **REMOVE CONTENTS FROM BOX. VERIFY ALL PARTS ARE PRESENT. READ INSTRUCTIONS CAREFULLY BEFORE STARTING INSTALLATION. CUTTING IS REQUIRED. TOW HOOKS MUST BE REMOVED.** It may be necessary to remove/relocate front license plate and license plate bracket. It is not required, but strongly recommended. If local/state law requires a license plate, license plate relocation kit is available.
2. Start installation from under the front of the vehicle. Remove the factory tow hook, (if equipped), located on the passenger side. **NOTE:** The tow hooks will not be reinstalled. It may be necessary to remove the lower plastic splash guard or air dam. Set air dam on a clean, stable working area.
3. Select the passenger side Mounting Bracket. Bolt the Bracket to the tow hook location on the bottom of the frame channel with the included (2) 12-1.25 x 35mm **Fine Thread** Hex Bolts, (2) 12mm Lock Washers and (2) 12mm Flat Washers. Do not tighten hardware at this time.
4. Repeat **Steps 2 – 3** for the driver side Bracket installation.
5. With assistance, position the Bull Bar onto the outside of the Mounting Brackets. Bolt the Bull Bar to the Mounting Brackets using the included (4) 12-1.75mm x 35mm **Coarse Thread** Hex Bolts, (4) 12mm Lock Washers, (8) 12mm Flat Washers and (4) 12mm Hex Nuts.
6. Align the Bull Bar properly and tighten all hardware bolting the (2) Brackets to the frame only. Do not tighten the Bull Bar hardware at this time. **(Figure 1).**
7. Remove the Bull Bar. Place the air dam in position over the Brackets. Carefully cut slots in the plastic splash guard or air dam to allow the Brackets to pass through. Remove as little plastic as possible for a clean installation. Once properly trimmed, re-install the air dam using the factory hardware. Re-install the Bull Bar as described in **Steps 5 – 6.** Tighten all hardware.
8. **LED Light Installation**
 - a. Use (2) 6mm Socket Head Cap Screw, (2) 6mm Lock Washers and (2) 6mm Flat Washers to attach the Light Bar Brackets to the Bull Bar, **(Figure 2).**
 - b. Follow the light manufacturer's instructions to attach the Bull Bar.
 - c. Follow light manufacturer's instructions to properly wire the Bull Bar

9. Do periodic inspections to the installation to make sure that all hardware is secure and tight.

To protect your investment, wax this product after installing. Regular waxing is recommended to add a protective layer over the finish. Do not use any type of polish or wax that may contain abrasives that could damage the finish.

For stainless steel: Aluminum polish may be used to polish small scratches and scuffs on the finish. Mild soap may be used also to clean the Bull Bar.

For gloss black finishes: Mild soap may be used to clean the Bull Bar.

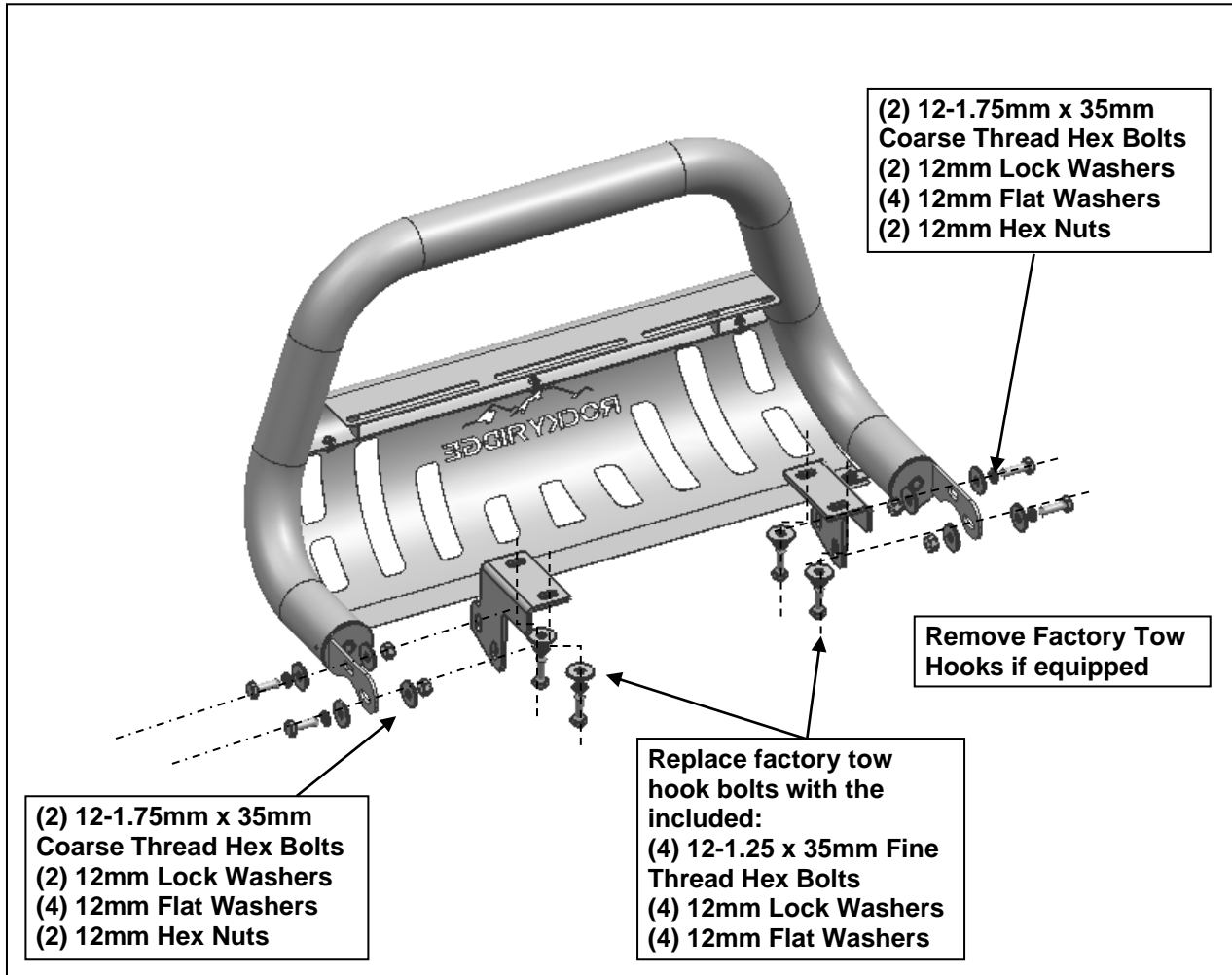

(Fig 1)

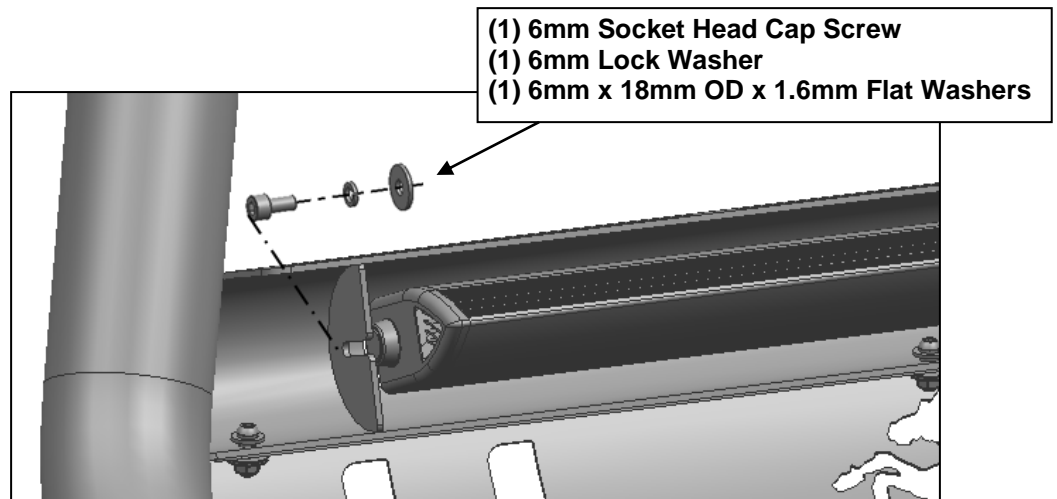

(Fig 2)