







INSTALLATION MANUAL

Lightweight Low Profile Tri-Fold Hard Tonneau Cover

(#109) 2020+ Jeep Gladiator

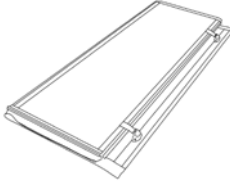

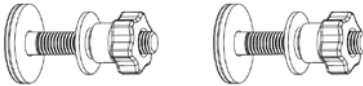
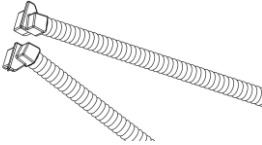
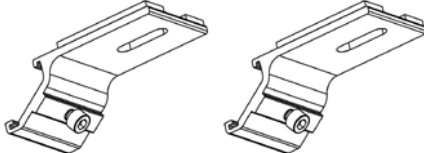
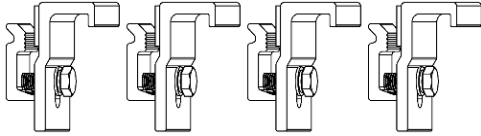
When you open the tonneau cover box you will see the parts:

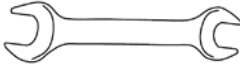
Item	Description	Qty	Picture
1-A	Tonneau Cover	1	
1-B	Left Side Rail	1	
1-C	Right Side Rail	1	
1-D	Front Bolt	2	
1-E	Drain Tube	2	
1-F	Front Support Plate (Including Bolts)	2	
1-G	Clamp Assembly	4	
1-H	Foam Seal Tape	1	
1-I	Allen Wrench	1	
1-J	#17 Wrench	1	

Steps:

1. Check contents of carton with the list above before beginning installation
2. If the front of the bed is lower than the side rails, stick the supplied foam seal tape on the front edge of the bed.

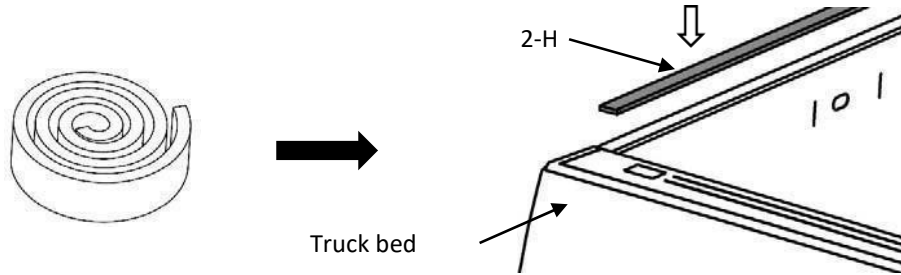

3. Slide the Front Support Plate (1-F) into the side rails (from front end), and move the Front Support Plate (1-F) to front of side rail.

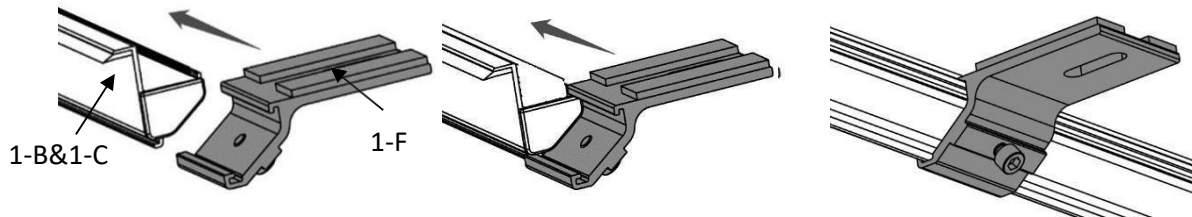

4. Insert the drain tubes(1-E) into the front of side rails.

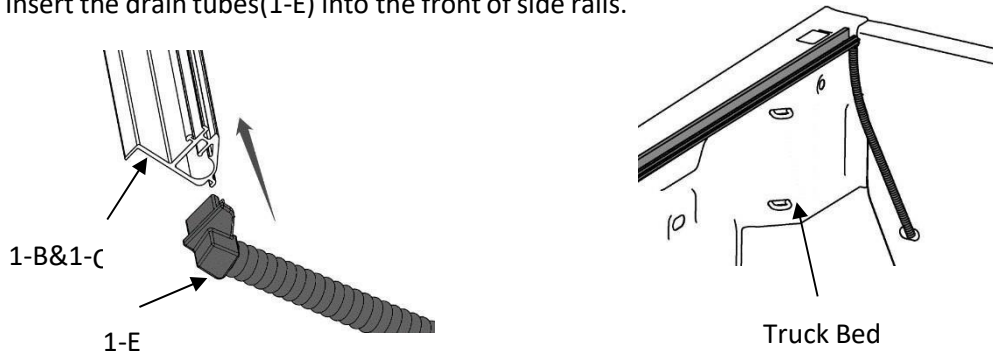

5. Unscrew and remove the aluminum block from the side rail. Insert the block into the truck bed Factory Track.

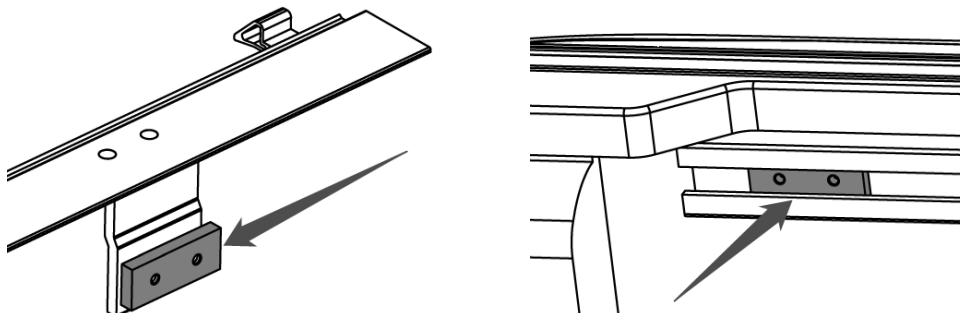

- Place the side rail on the bed rail, and push it to the front wall of truck bed. Then bolt the side rail with the aluminum block (already in the Factory Track in Step 5) together. Tighten the clamps each side.

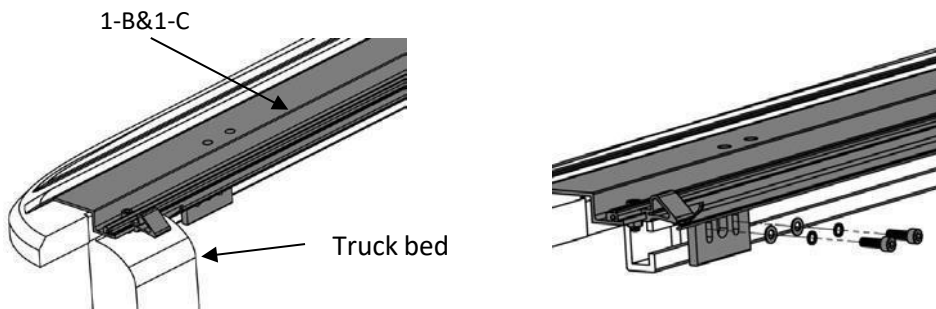

- Place the bed cover on the front end of truck bed. Ensure the cover is even on all sides and sit firmly on side rails.

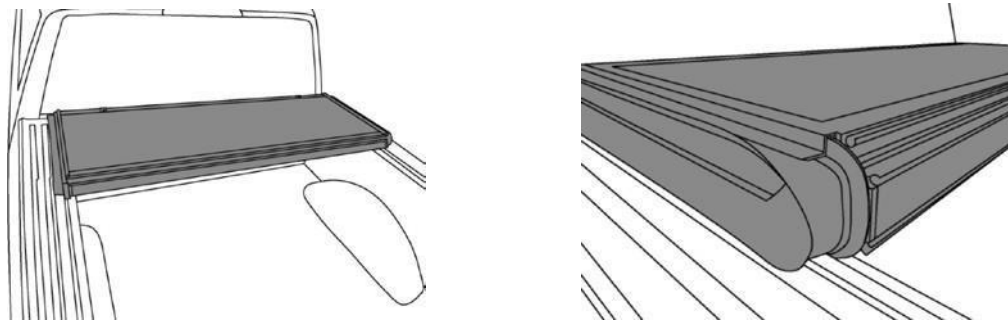

- Adjust the front support plate (1-F) to correct position, insert the front bolt with rubber washer into the holes on the cover front panel and front support plate. Then tighten the hand nut under the front support plate.

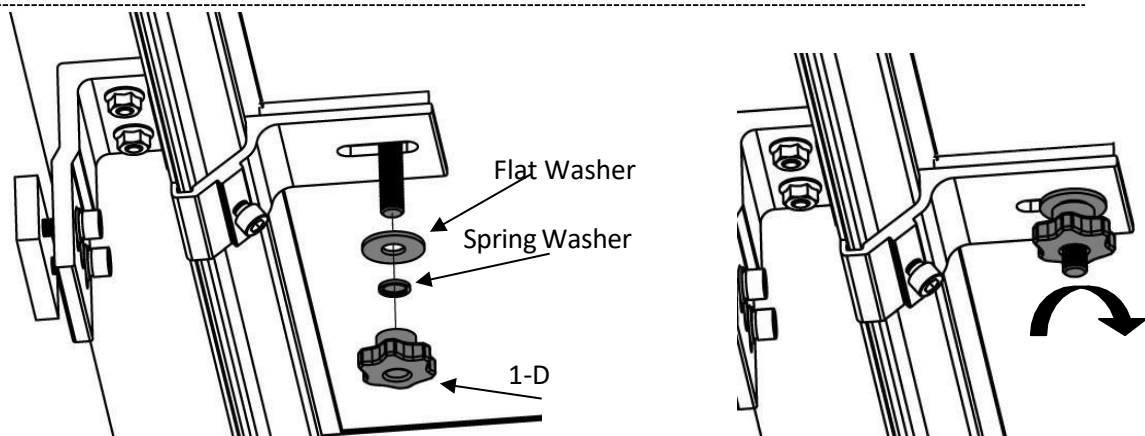

※ATTENTION: Make sure the Flat Washer and Spring Washer are all placed on bolt before screw the plastic nut on.

9. Unfold the cover, ensure the panel latch engages with the rail retainer latch on the side rails. If necessary, adjust the rail latch to match the panel latch position. Tighten the side rail retainer latch. Lock the cover and close the tailgate.

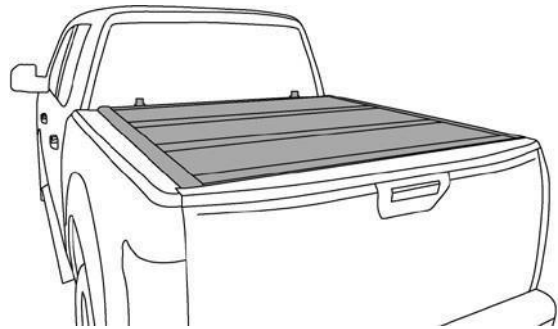
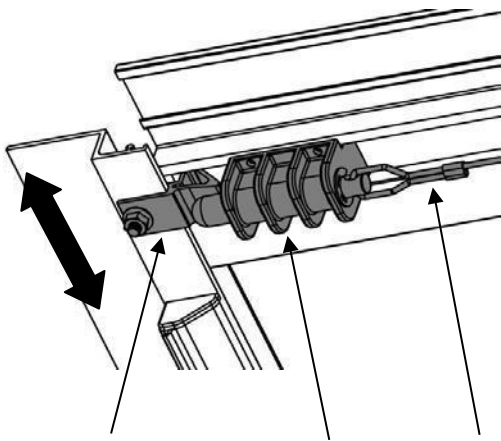
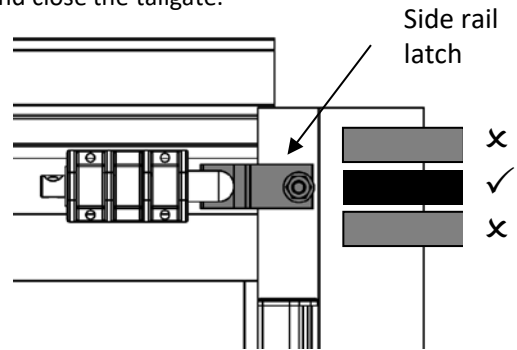
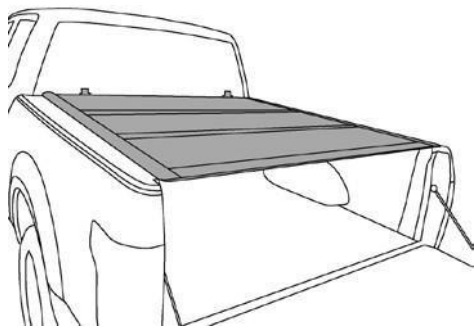

Side rail latch

Panel Latch

Lock Cable

ATTENTION: TIGHTEN ALL BOLTS & NUTS BEFORE DRIVING!

For Trucks without Factory Track System:

Step 4 and 5 above are changed to the following steps:

Step-1 Remove the Clamp Assembly from the Side Rail (1-B&1-C).

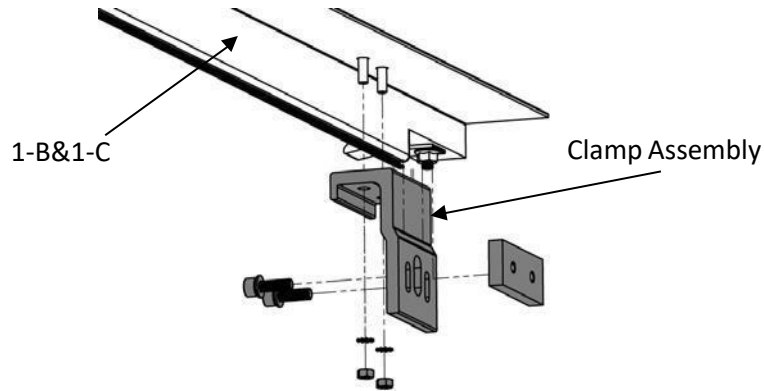

Step-2 Attach and Install the other set of Clamp Assembly (2-G) to the Side Rail (1-B&1-C), then tighten the nuts.

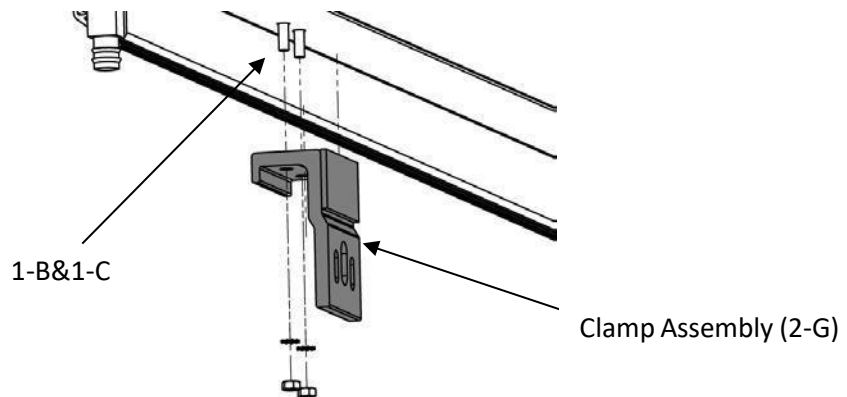

Step-3 Place the side rail on the bed rail, and push it to the front wall of truck bed. Place one clamp at the front of the side rail and one at the rear (please make sure the rear clamps is placed on the position that is closest to tailgate). Tighten the clamps each side.

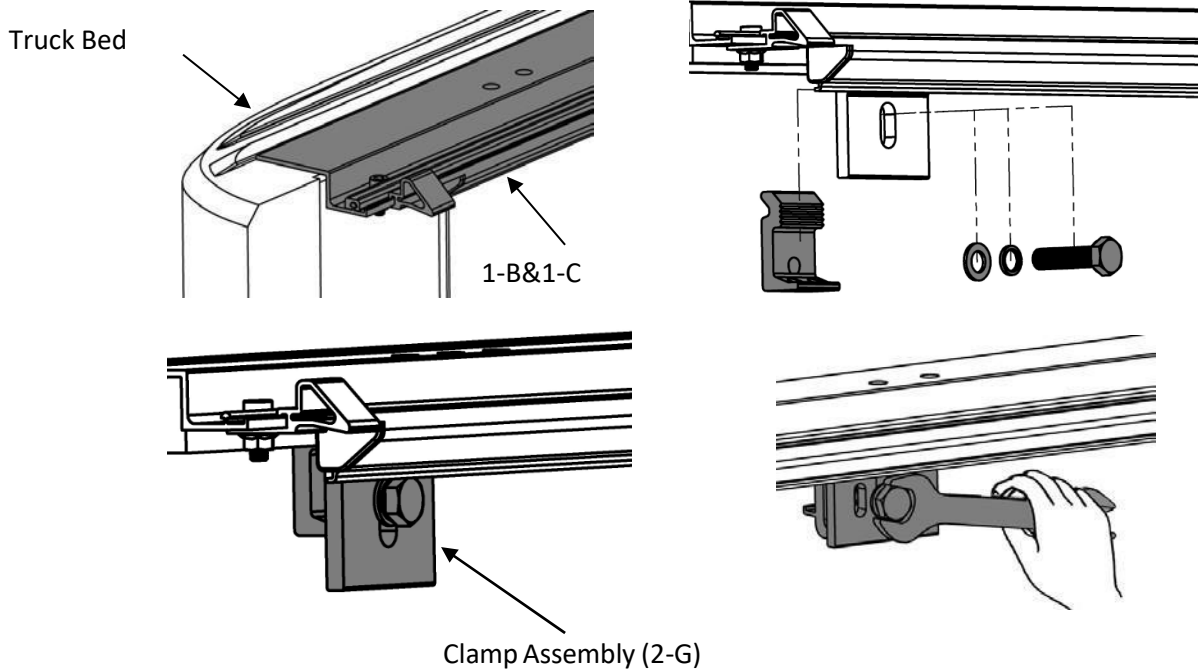

Safety Buckles Instructions option

For Truck bed without Utility Track System, when you open the cover, there are two safety buckles on each side of the cover front panel.

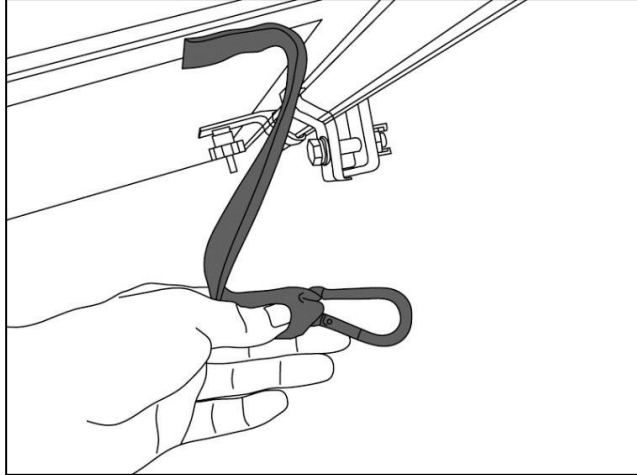

When installing the side rail, make sure one side rail clamp (2-G) is installed nearby the Strap Safety Buckle position.

There are two holes on the clamp. Snap the safety buckle into the hole of the clamp.

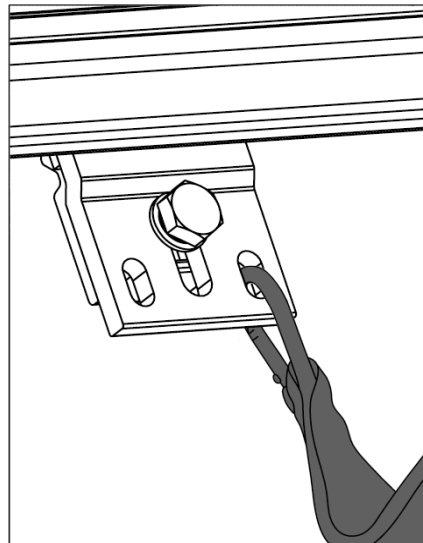
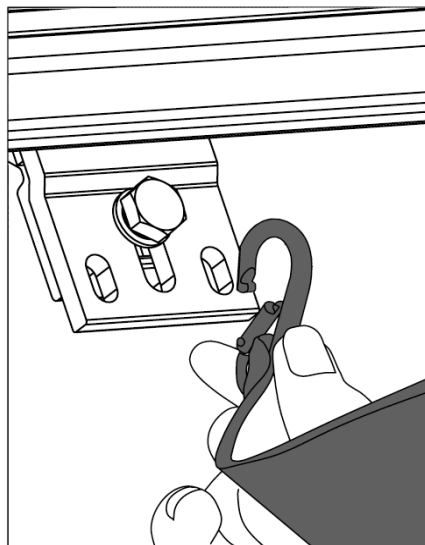

WARNING:

Always secure the safety straps to the truck bed. Never drive with a cover in partially opened position.