



# TC4 HD RUNNING BOARDS

(2020-2025+ GLADIATOR JT)

---

## INSTALLATION INSTRUCTIONS

### CONTENTS

---

- (1) LH Running Board
- (1) RH Running Board
- (3) LH Step Brackets [DF, DC, DR]
- (3) RH Step Brackets [PF, PC, PR]
- (6) M8 x 25mm Hex Bolts
- (12) M8 x 24mm OD x 2mm Flat Washers
- (6) M8 Lock Nuts
- (6) M8 x 35mm Hex Bolts
- (6) M8 Lock Washers
- (6) M8 x 28mm OD x 3mm Flat Washers
- (6) M8 x 25mm Combo Bolts
- (12) M6 x 1.00 x 25mm Hex Bolts
- (24) M6 Flat Washers
- (12) M6 Lock Nuts

### TOOLS REQUIRED

---

10mm,13mm  
Sockets/Wrenches  
Ratchet

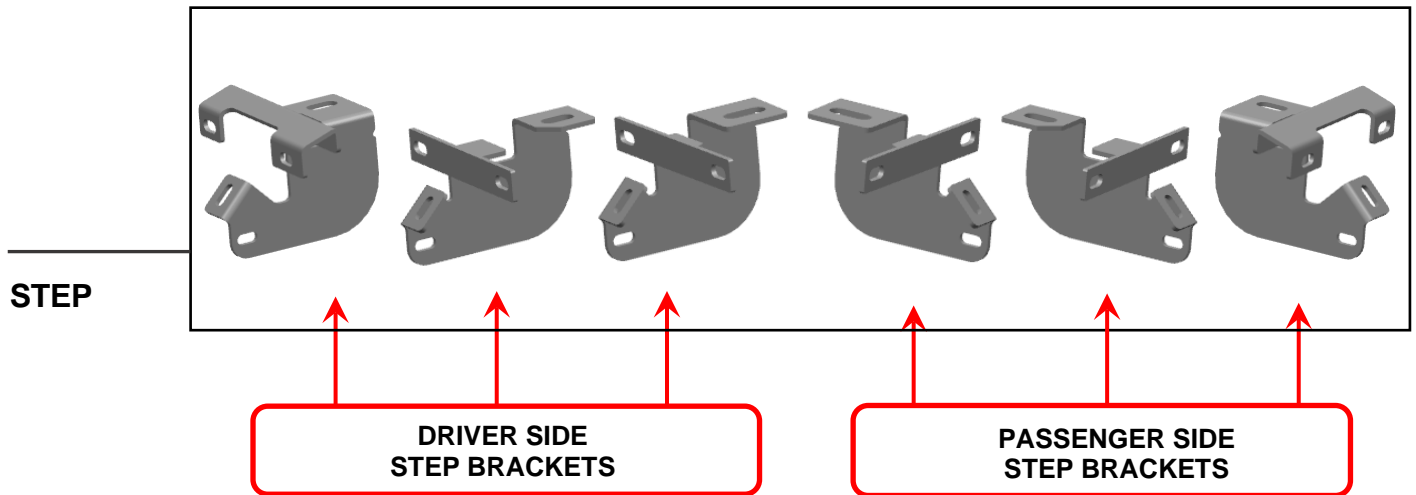

Please identify each mounting bracket using the engraved location identifier. **Notice: Mounting Brackets look very similar but are unique.**

DF: Driver Front  
DC: Driver Center  
DR: Driver Rear

PF: Passenger Front  
PC: Passenger Center  
PR: Passenger Rear

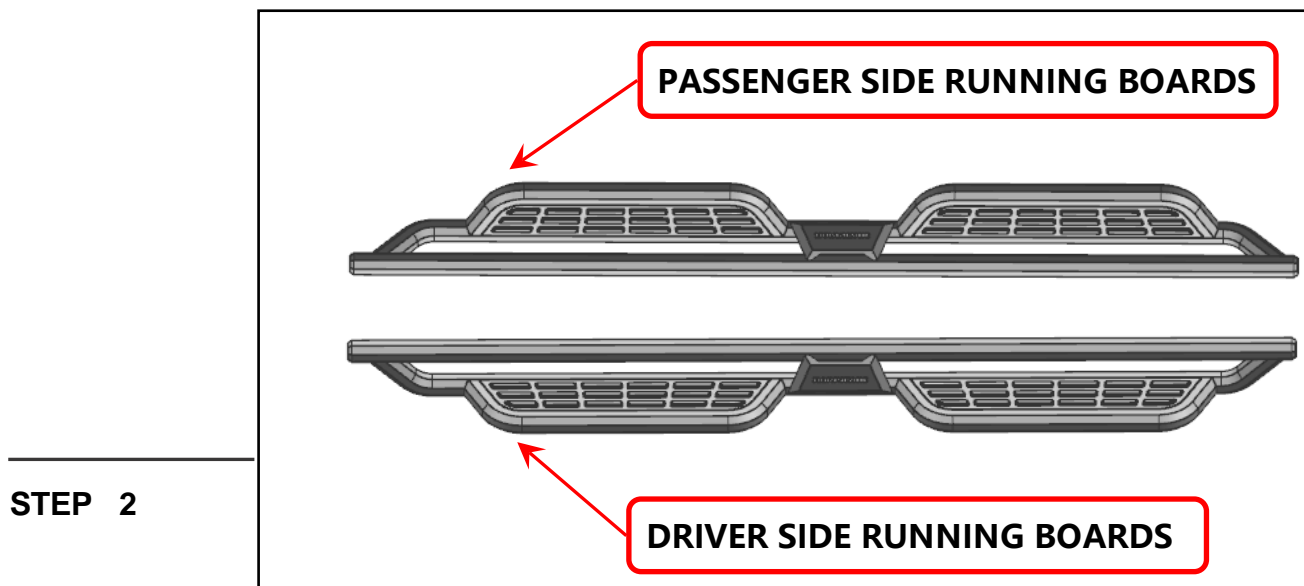

Identify each running board by identifier on the front. **Notice: "D" for Driver/Left Side; "P" for Passenger/Right Side.**

## STEP 3

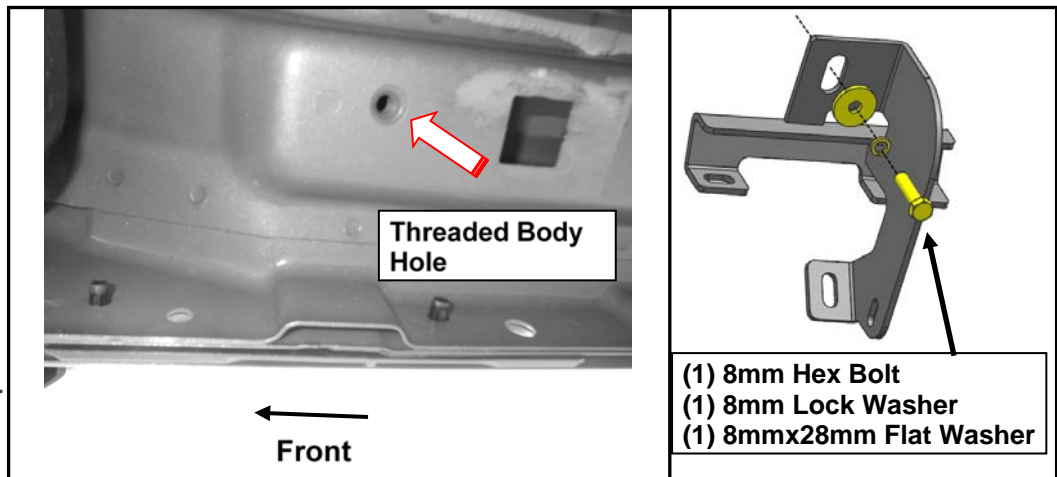

Start installation toward the front of the Passenger/Right side of the vehicle

Loosely fit the (1) step bracket to the vehicle threaded body hole using (1) M8x35mm bolt, (1) M8 lock washer, and (1) M8 x 28mm flat washer [large OD]. Do not fully tighten to allow for later adjustments. Repeat this step for all step brackets.

## STEP 4

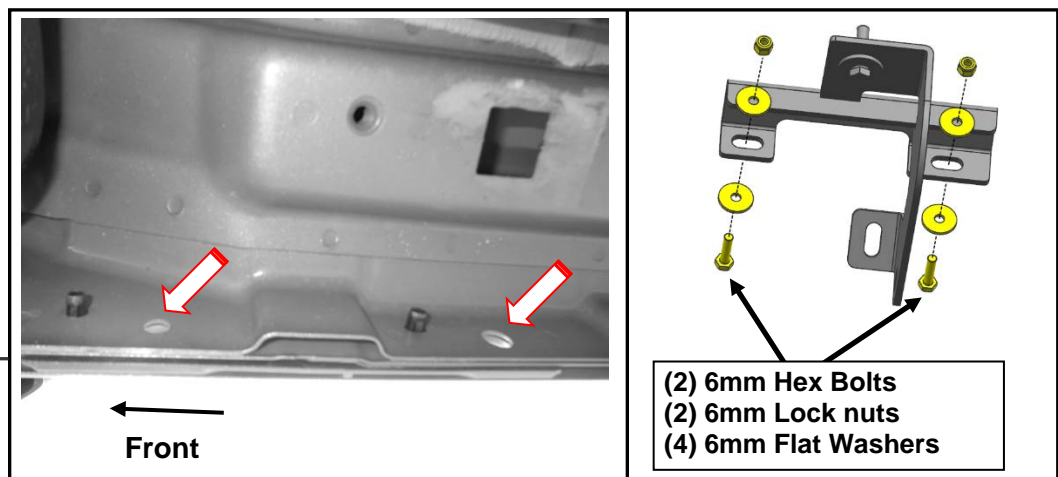

Loosely fit the Passenger Front reinforcement bracket to the **inside of the vehicle pinch weld** using (2) M6 x 25mm hex bolts, (4) M6 flat washers, and (2) M6 lock nuts. Do not fully tighten to allow for later adjustments. Repeat this step for all Passenger reinforcement brackets.

## STEP 5

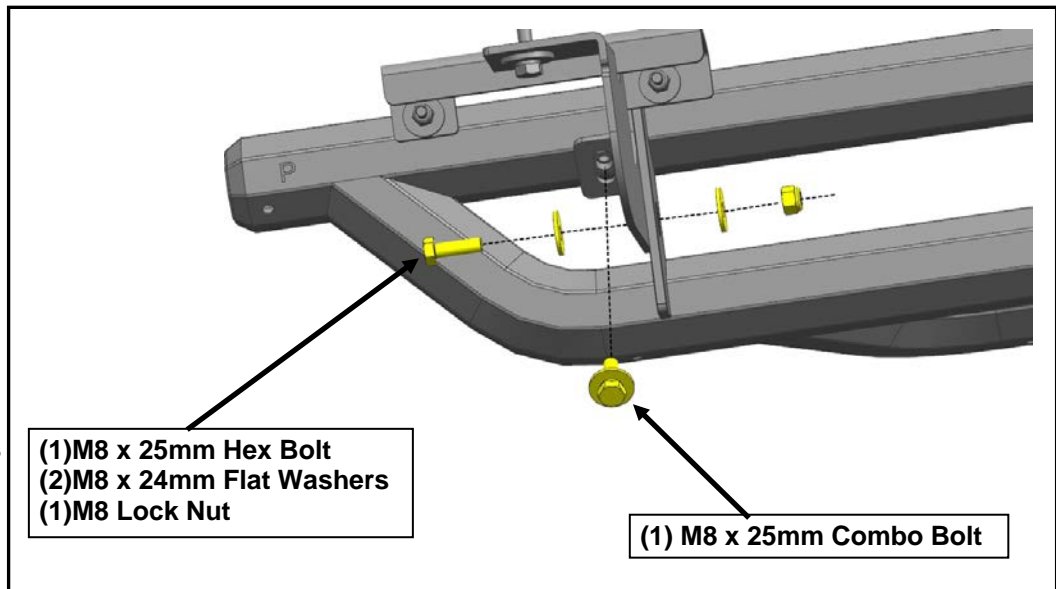

With all brackets loosely mounted to the vehicle, fit the running board onto the front bracket, and loosely secure into place using (1) M8 x 25mm combo bolt, (1) M8 x 25mm hex bolt, (2) M8 x 24mm flat washers, (1) M8 lock nut. Repeat the step for other (2) PS step brackets.

## STEP 6

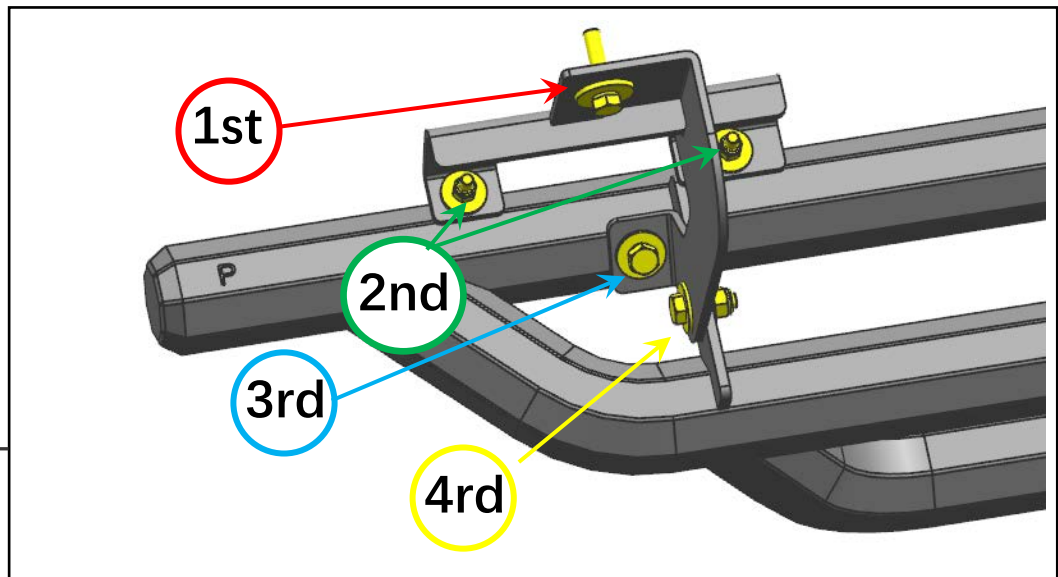

Tighten the mounting brackets to the vehicle. Adjust the running board to the desired angle, and tighten the bolts to secure the step into place. See photo for tightening order visual.

Repeat steps 1-6 for the remaining running board.

Installation is now complete.