

REDROCK

TC3 HD ROCKER STEP

PART #: JG42147

FITS: 2020-Up Jeep Gladiator JT



60-120 min



Cutting Not Required



Drilling Not Required

Torque & Tools

Fastener Size	Tightening Torque (ft-lbs)	Wrench Required	Allen Wrench Required
■ 6mm	■ 7-8.5		
■ 8mm	■ 18-20		
■ 10mm	■ 35-40		
□ 12mm	□ 60-70		
		■ 10mm	□ 4mm
		■ 13mm	□ 5mm
		■ 16mm	□ 6mm
		□ 18mm	□ 8mm

BEFORE INSTALLATION

REMOVE CONTENTS FROM BOX. VERIFY ALL PARTS ARE PRESENT. READ INSTRUCTIONS CAREFULLY BEFORE STARTING INSTALLATION. ASSISTANCE IS RECOMMENDED.

Part List

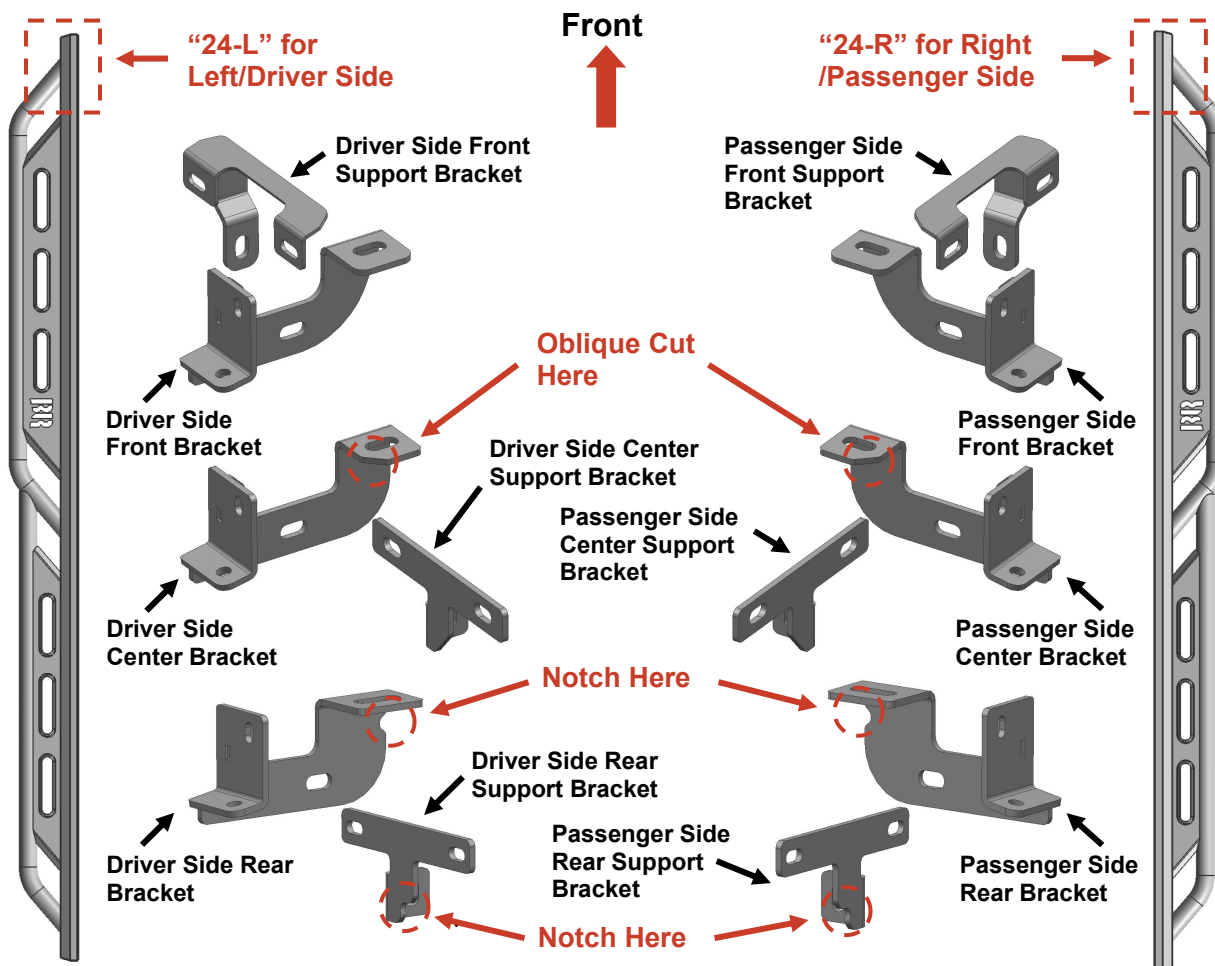

REDROCK

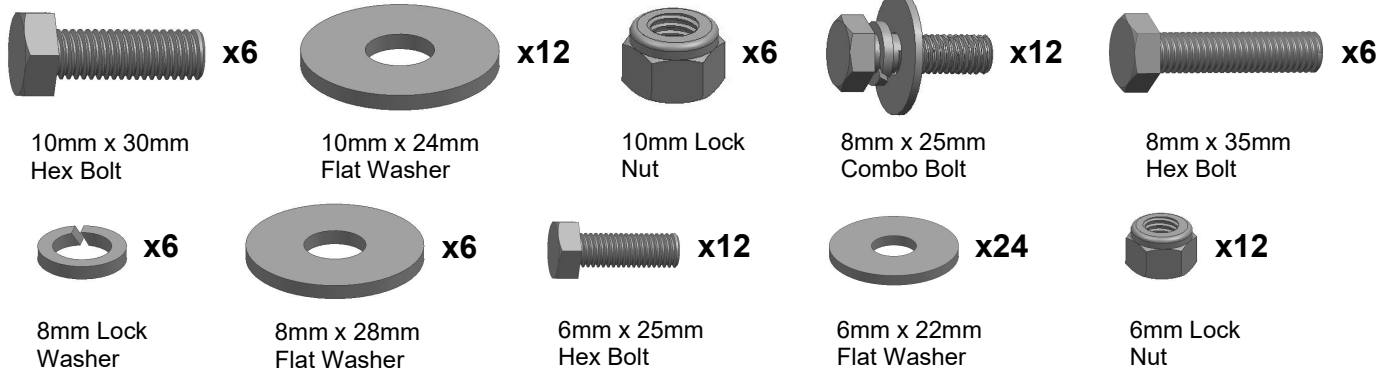

PLEASE NOTE THAT THE FOLLOWING PICTURES ARE BASED ON THE PASSENGER SIDE INSTALLATION

STEP 1

Start installation on the Passenger/Right front of the of the vehicle. Find the front threaded insert located in between the first pair of holes along the pinch weld, (Fig 1).

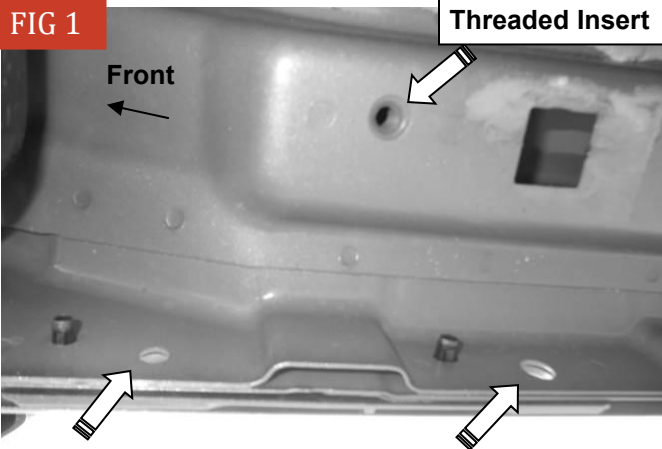

(Fig 1) Passenger/Right side front mounting location with threaded insert

STEP 2

Select the Passenger/Right Front Mounting Bracket. **IMPORTANT:** Mounting Brackets look very similar but are unique. The **Center Mounting Bracket** has an **Oblique Cut** on the top. The **Rear Mounting Bracket** has a **Notch** in the rear. Please identify the Front, Center, Rear Brackets according to the illustration on Part List. Attach the Mounting Bracket to the threaded insert using (1) 8mm Hex Bolt, (1) 8mm Lock Washer and (1) 8mm Flat Washer, (Fig 2). Do not tighten hardware.

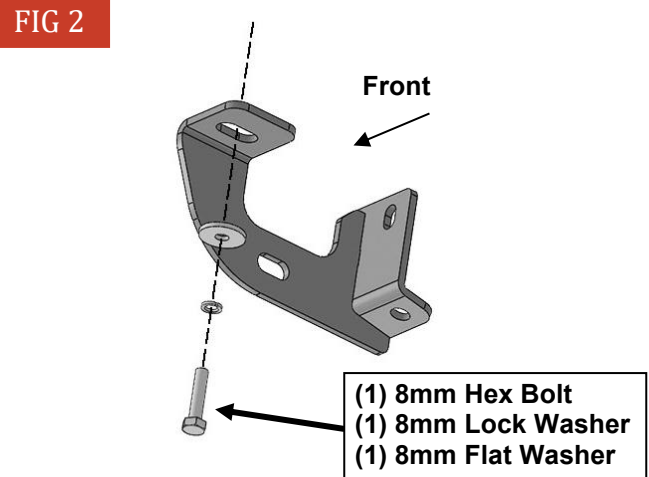

(Fig 2) Attach the Passenger/Right Front Mounting Bracket to the front location

REDROCK

STEP 3

Select the Passenger/Right Front Support Bracket. **IMPORTANT:** Please identify the **Front, Center, Rear Support Brackets** according to the illustration on Part List. Attach the Support Bracket to the pinch weld using (2) 6mm Hex Bolts, (4) 6mm Flat Washers and (2) 6mm Nylon Lock Nuts, (Fig 3). **NOTE: Insert Bolts from the outside of the pinch weld, (Fig 4).** Attach the Support Bracket to the Mounting Bracket with (1) 10mm Hex Bolt, (2) 10mm Flat Washers and (1) 10mm Nylon Lock Nut, (Fig 5 & 6). Do not tighten hardware.

FIG 3

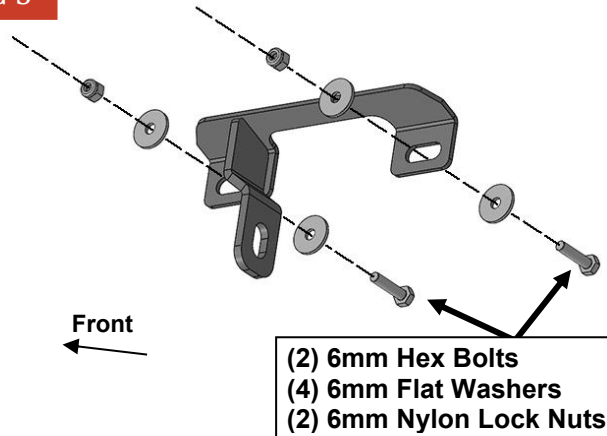

(Fig 3) Attach the Passenger/Right Front Support Bracket to the pinch trim

FIG 4



(Fig 4) Insert Bolts from the outside of the pinch weld.

FIG 5

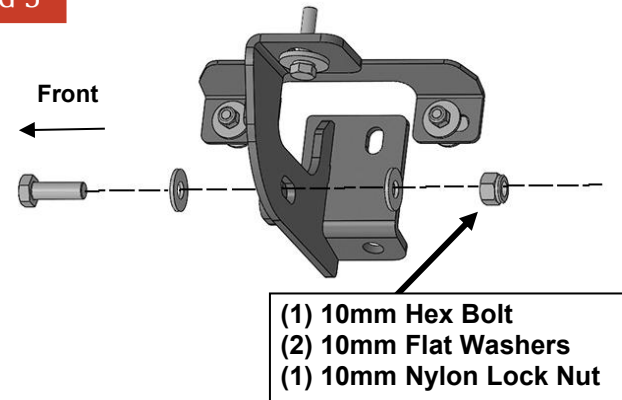

(Fig 5) Attach the Passenger/Right Front Support Bracket to the Mounting Bracket

FIG 6



(Fig 6) Passenger/Right front mounting bracket and support bracket attached.

STEP 4

Move to the center mounting location and locate the threaded insert and pair of holes in the pinch weld, (Fig 7). Repeat **Steps 2 & 3** to attach the Passenger/Right Center Mounting Bracket and Passenger/Right Center Support Bracket (Figs 8-10). **IMPORTANT:** The **Center Mounting Bracket** has an **Oblique Cut** on the top. The **Rear Mounting Bracket** has a **Notch** in the rear. (Fig 8). The **Rear Support Bracket** has a **Notch** in the rear (Fig 9). Do not tighten hardware.

REDROCK

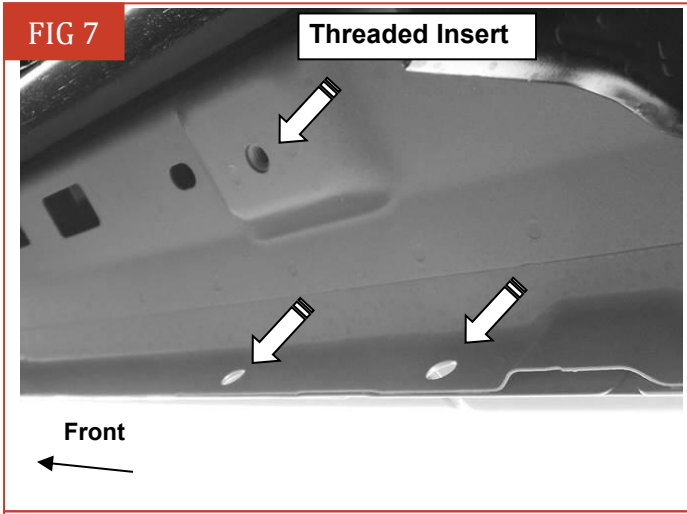

(Fig 7) Passenger/Right center mounting location

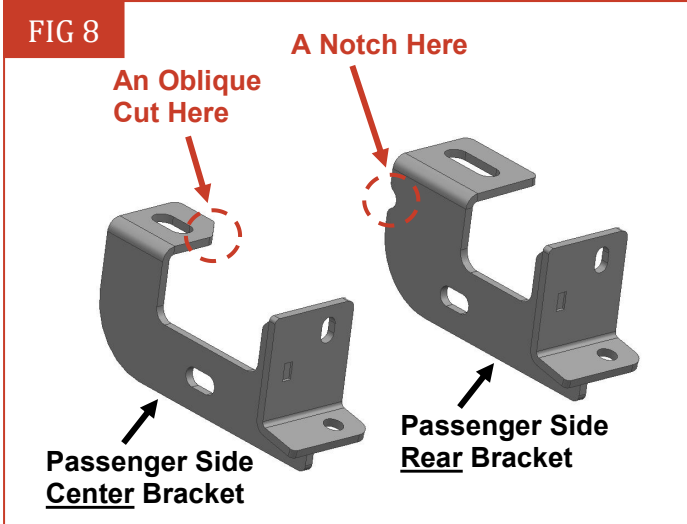

(Fig 8) The Center and Rear Mounting Brackets are similar but are unique

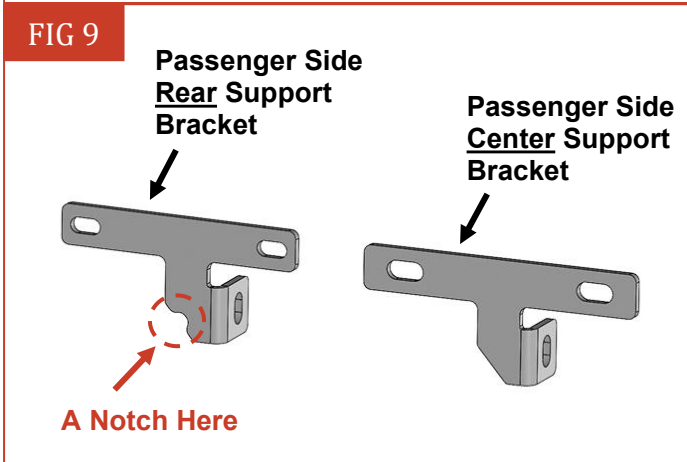

(Fig 9) The Center and Rear Support Brackets are similar but are unique



(Fig 10) Attach Passenger/Right Center Bracket and Passenger/Right Center Support Bracket to the center location

STEP 5

Move to the rear mounting location on the rocker panel and locate the threaded insert and pair of holes in the pinch weld, (Fig 11). Repeat **Steps 2 & 3** to attach the Passenger/Right Rear Mounting Bracket (Fig 8) and Passenger/Right Rear Support Bracket (Fig 9), (Fig 12). **IMPORTANT:** The **Rear Mounting Bracket** has a **Notch** in the rear. (Fig 8). The **Rear Support Bracket** has a **Notch** in the rear (Fig 9). Do not tighten hardware.

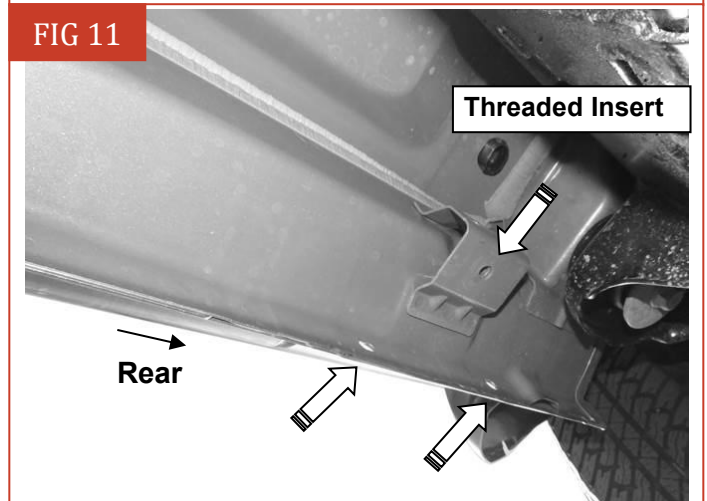

(Fig 11) Passenger/Right rear mounting location

REDROCK

FIG 12



(Fig 12) Attach Passenger/Right Rear Bracket and Passenger/Right Rear Support Bracket to the rear location

STEP 6

Select the Passenger/Right Running Board.
NOTE: The Passenger/Right Running Board will have a “24-R” on the front. Attach the Running Board to the Mounting Brackets with (6) 8mm Combo Bolts, (Fig 13). **IMPORTANT:** Do not slide Running Board on the Mounting Bracket cradles, or damage to the finish may result. Do not tighten hardware.

FIG 13

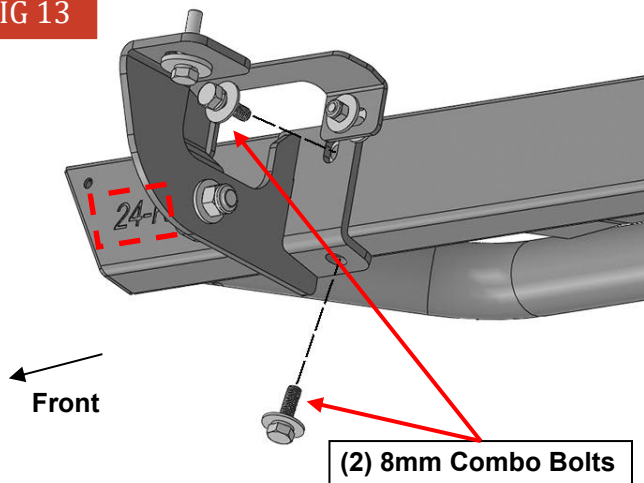

(Fig 13) Attach the Passenger/Right Running Board to the Mounting Brackets

STEP 7

Level and adjust the Running Board and tighten all hardware.

STEP 8

Repeat **Steps 1—7** to attach Driver/Left Running Board.

STEP 9

Do periodic inspections to the installation to make sure that all hardware is secure and tight.

Attention

To protect your investment, do not use any type of polish or wax that may contain abrasives that could damage the finish.

Mild soap may be used also to clean the Running Boards.