



---

# 6-INCH RUNNING BOARDS

(2020-2023+ GLADIATOR JT)

---

## INSTALLATION INSTRUCTIONS

### CONTENTS

---

- (1) LH Running Board
- (1) RH Running Board
- (3) LH Step Brackets [DF, DC, DR]
- (3) LH Reinforcement Brackets [DF, CF, DR]
- (3) RH Step Brackets [PF, PC, PR]
- (3) RH Reinforcement Brackets [PF, PC, PR]
- (6) M10 x 1.50 x 30mm Hex Bolts
- (12) M10 Flat Washers
- (6) M10 Lock Nuts
- (6) M8 x 1.25 x 35mm Hex Bolts
- (6) M8 Lock Washers
- (6) M8 Flat Washers
- (12) M8 x 25mm Combo Bolts
- (12) M6 x 1.00 x 25mm Hex Bolts
- (24) M6 Flat Washers
- (12) M6 Lock Nuts

### TOOLS REQUIRED

---

10mm,13mm,16mm,17mm  
Sockets/Wrenches  
Ratchet

SKU # JG28613

Edited:12/08/2023

## STEP 1

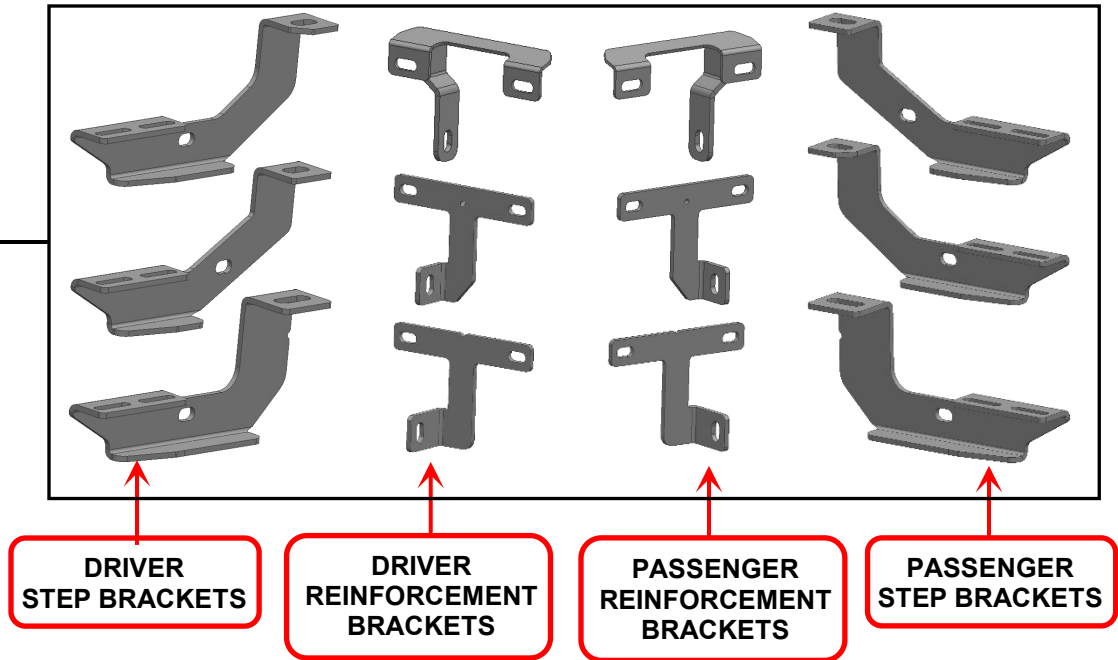

Mounting Brackets and Reinforcement brackets look very similar but are unique. Please identify each mounting bracket using the engraved location identifier.

DF: Driver Front  
DC: Driver Center  
DR: Driver Rear

PF: Passenger Front  
PC: Passenger Center  
PR: Passenger Rear

## STEP 2

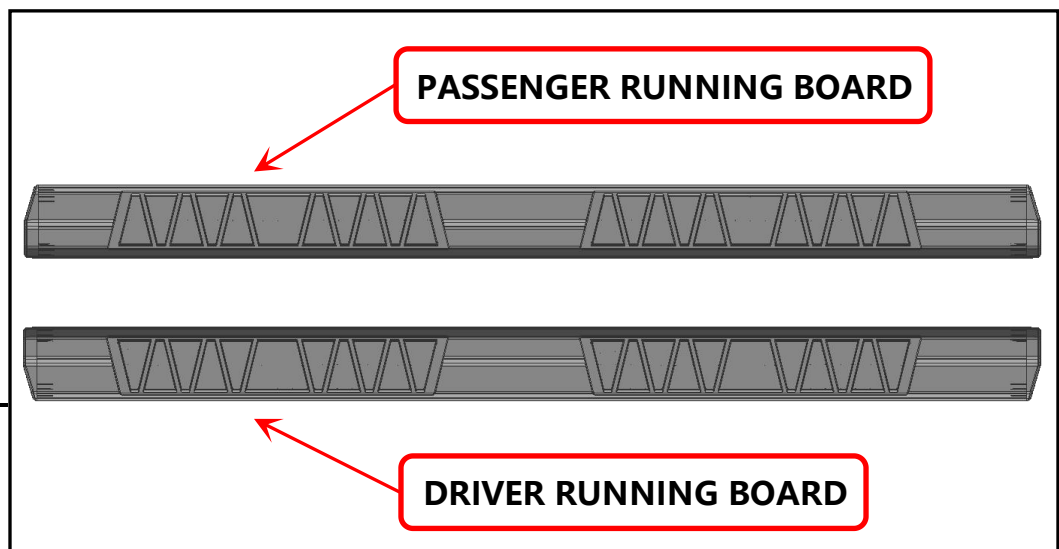

Identify each Running Board by the front of the step. Notice: “D” for Driver/Left Side; “P” for Passenger/Right Side.

## STEP 3

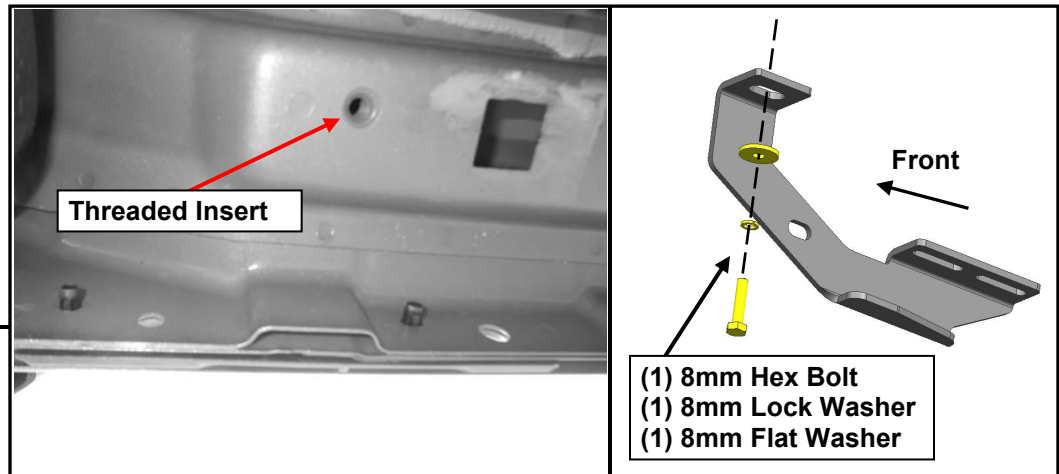

Start installation toward the front of the Passenger/Right side of the vehicle.

Loosely fit the (1) Passenger Front step bracket to the vehicle threaded body hole using (1) M8x35mm bolt, (1) M8 lock washer, and (1) M8 flat washer. Do not fully tighten to allow for later adjustments. Repeat this step for all step brackets.

## STEP 4

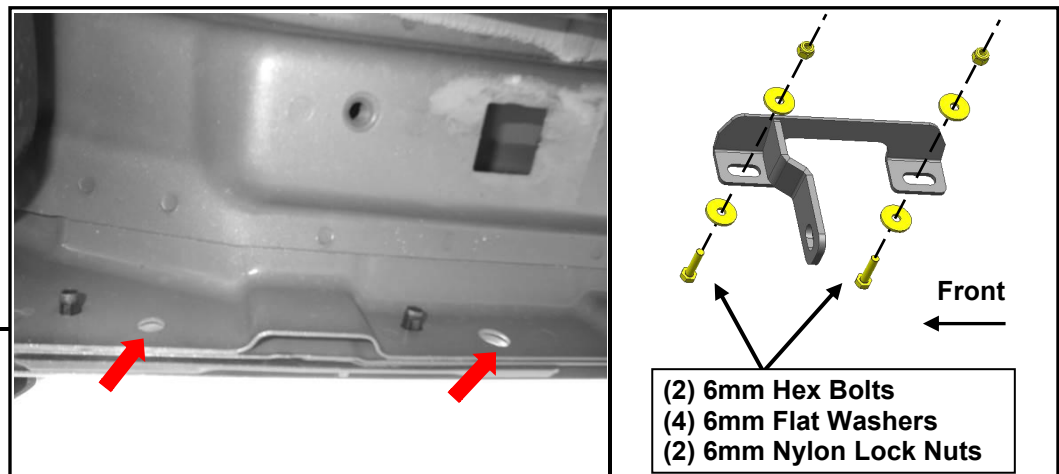

Loosely fit the Passenger Front reinforcement bracket to the inside of the vehicle pinch weld using (2) M6x25mm bolts, (4) M6 flat washers, and (2) M6 lock nuts. Do not fully tighten to allow for later adjustments.

## STEP 5

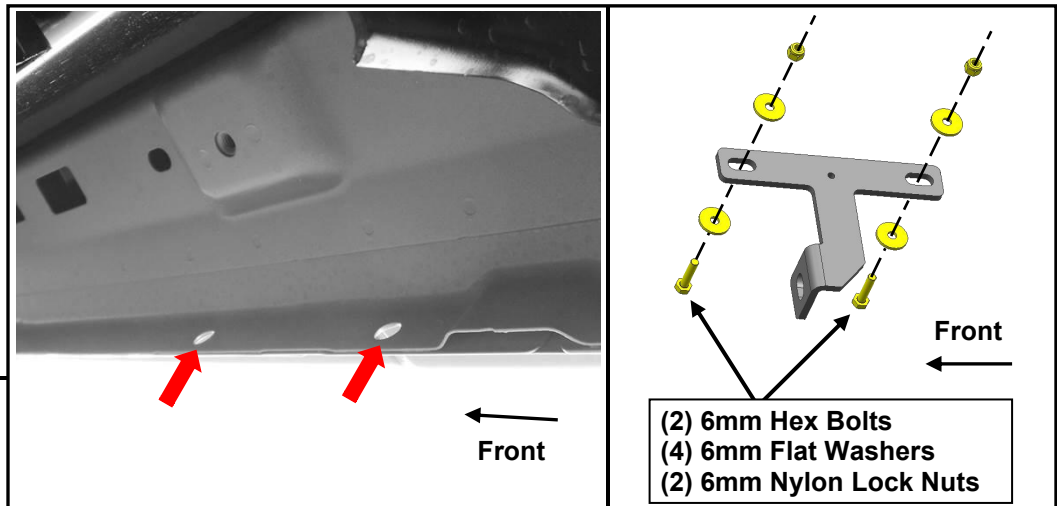

Loosely fit the Passenger Center reinforcement bracket to the inside of the vehicle pinch weld using (2) M6x25mm bolts, (4) M6 flat washers, and (2) M6 lock nuts. Do not fully tighten to allow for later adjustments.

Repeat this step for Passenger Rear reinforcement brackets.

## STEP 6

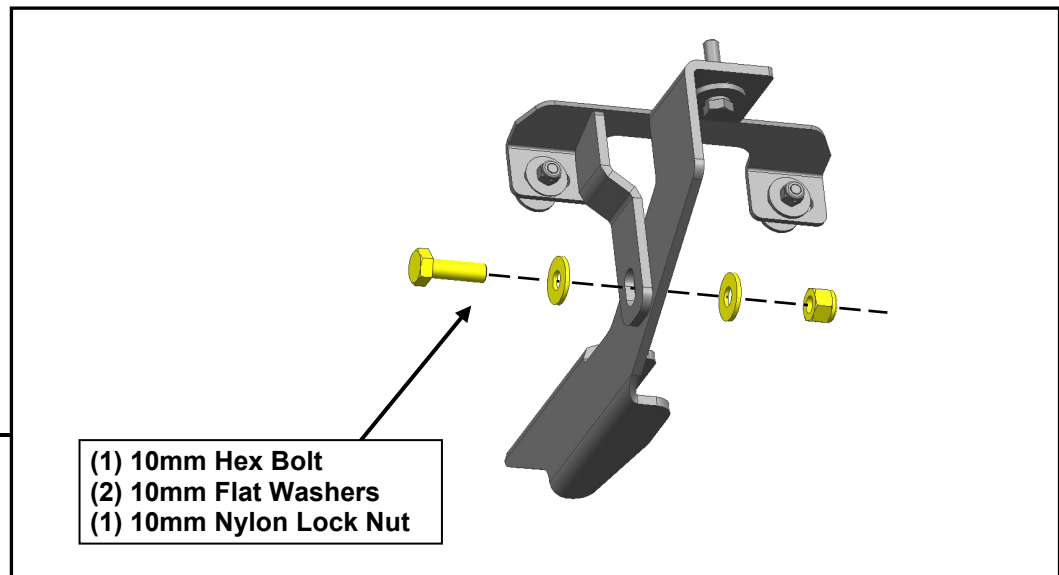

Loosely attach the (1) Passenger Front step bracket to the (1) Passenger Front reinforcement bracket using (1) M10 bolt, (2) M10 flat washers, and (1) M10 nylon lock nut.

Repeat this step for all step brackets.

## STEP 7

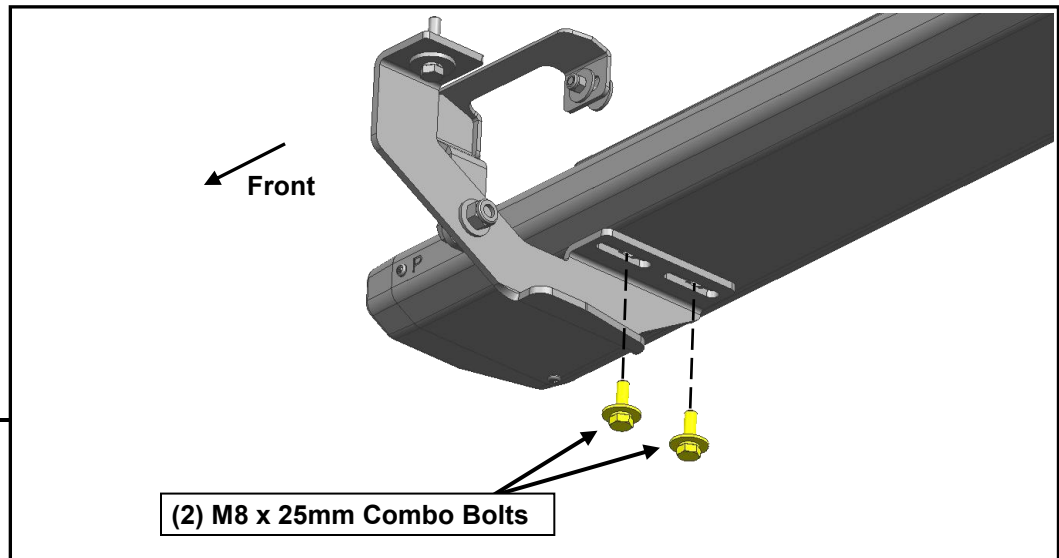

With all brackets loosely mounted to the vehicle, fit the Running Board onto the brackets, and loosely secure into place using (6) M8 x 25mm combo bolts.

## STEP 8

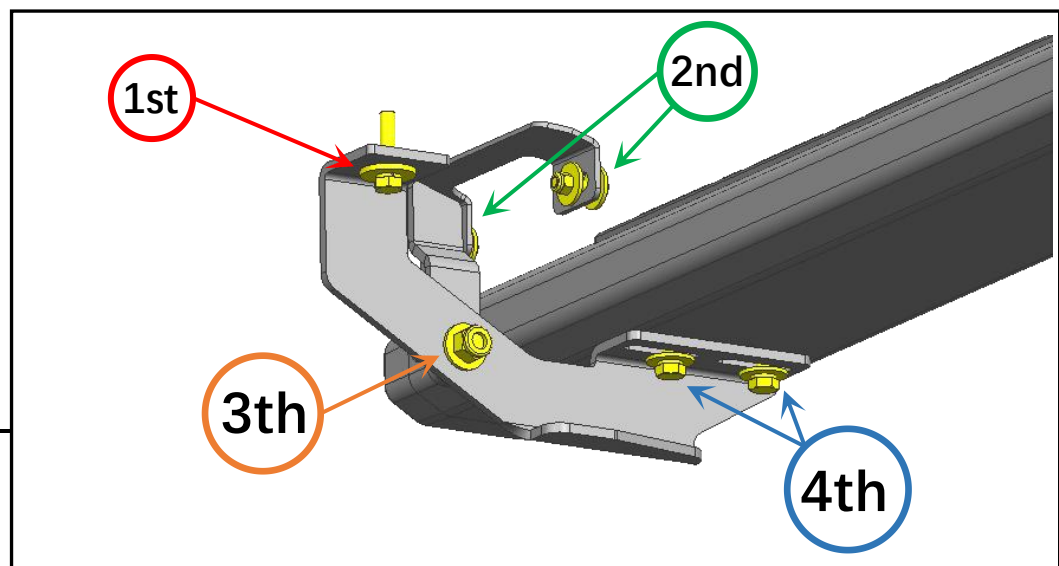

Tighten the mounting brackets to the vehicle. Adjust the Running Board to the desired angle, and tighten the M8 combo bolts to secure the step into place. See photo for tightening order visual.

Repeat steps 1-8 for the remaining Running Board.

Installation is now complete.