

PARTS LIST:

1	Driver/Left Bed Guard	16	12mm x 24mm OD x 2.5mm Flat Washers
1	Passenger/Right Bed Guard	8	12mm Nylon Lock Nuts
1	Driver/Left Mounting Bracket	4	10-1.5mm x 40mm Hex Bolts
1	Passenger/Right Mounting Bracket	4	10-1.5mm x 25mm Hex Bolts
2	14mm x 30mm OD x 65mm Spacer Tube	8	10mm Lock Washers
2	12-1.75mm x 110mm Hex Bolts	10	10mm x 30mm OD x 2.5mm Flat Washers
6	12-1.75mm x 40mm Hex Bolts	2	Rubber Trims

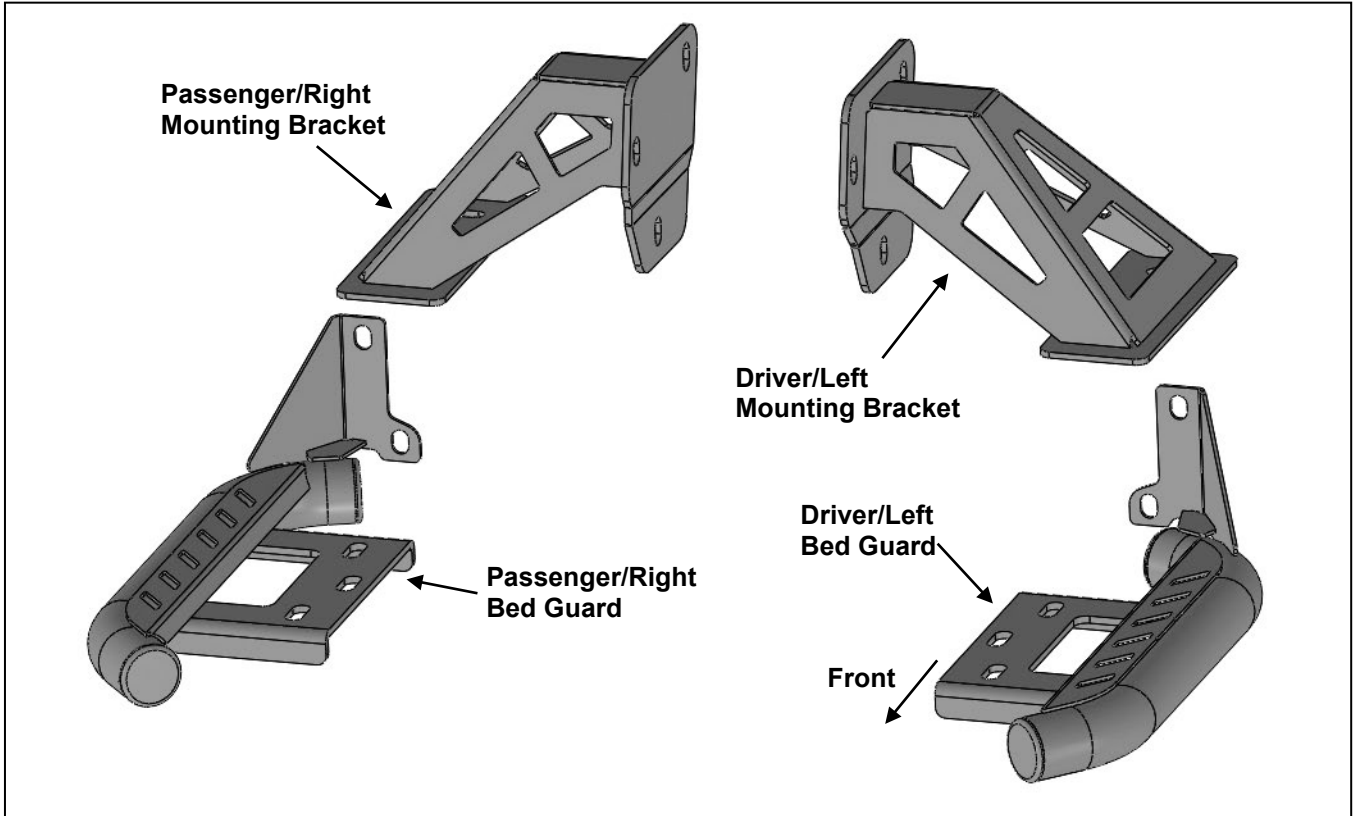

PROCEDURE:

REMOVE CONTENTS FROM BOX. VERIFY ALL PARTS ARE PRESENT. READ INSTRUCTIONS CAREFULLY BEFORE STARTING INSTALLATION. BUMPER IS HEAVY, ASSISTANCE IS RECOMMENDED TO AVOID POSSIBLE INJURY OR DAMAGE TO THE VEHICLE. CUTTING MAY BE REQUIRED.

1. Start installation from under the rear bumper. Determine if the vehicle is equipped with factory bed guards:

Models not equipped with bed guards

- a. Remove the steel support bracket from the inner edge of the bumper, **(Figures 1 & 2)**.
- b. Cut the plastic pin at the top of the bumper to remove the plastic support bracket, **(Figure 3)**.

Models equipped with bed guards

- a. Remove the lower bolt attaching the bed guard to the hitch, **(Figure 4)**.
- b. Remove the bolts attaching the bed guard to the rear bumper, **(Figure 5)**.
- c. Remove the upper bolts attaching the bed guard to the side of the frame, **(Figures 6 & 7)**.
IMPORTANT: The bed guard is heavy; assistance is recommended to hold the bed guards during hardware removal to prevent injury or damage.

2. Select the Driver/Left Bed Guard and Mounting Bracket. Attach the Bed Guard to the Mounting Bracket with (3) 12mm Hex Bolts, (6) 12mm Flat Washers and (3) 12mm Nylon Lock Nuts, **(Figures 8 & 9)**. Do not tighten hardware.

3. For models not equipped with bed guards

- a. Hold the Bed Guard assembly up to the mounting location.

- b. Place the bumper onto the vehicle to verify location before cutting. Mark the location of the Bed Guards onto the plastic factory bumper, **(Figure 10)**. **NOTE:** Use a hacksaw or sharp knife to carefully cut the plastic bumper. Check the fit and trim as necessary.
 - c. Trim the bumper so the Bed Guard will fit
 - 4. Attach the upper (2) holes in the Mounting Bracket plate to the side of the frame with (2) 10mm x 40mm Hex Bolts, (2) 10mm Lock Washers and (2) 10mm Flat Washers, **(Figure 11)**. Do not tighten hardware.
 - 5. Attach the lower hole in the Mounting Bracket plate to the side of the frame with (1) 12mm x 110mm Hex Bolt, (2) 12mm Flat Washers, (1) 14mm Spacer Tube and (1) 12mm Nylon Lock Nut, **(Figure 11)**. **NOTE:** The Spacer Tube is required for models not equipped with a receiver hitch, **(Figure 12)**. Do not tighten hardware.
 - 6. Attach the Bed Guard to the rear bumper with (2) 10mm x 25mm Hex Bolts, (2) 10mm Lock Washers and (2) 10mm Flat Washers, **(Figure 12)**. Do not tighten hardware.
 - 7. Level and adjust the Bed Guard and tighten all hardware.
 - 8. Repeat **Steps 1—7** to attach the Passenger/Right Bed Guard.
 - 9. Do periodic inspections to the installation to make sure that all hardware is secure and tight.
- To protect your investment,** Do not use any type of polish or wax that may contain abrasives that could damage the finish. Mild soap may be used to clean the Bumper assembly.

Driver/Left Side Installation Pictured

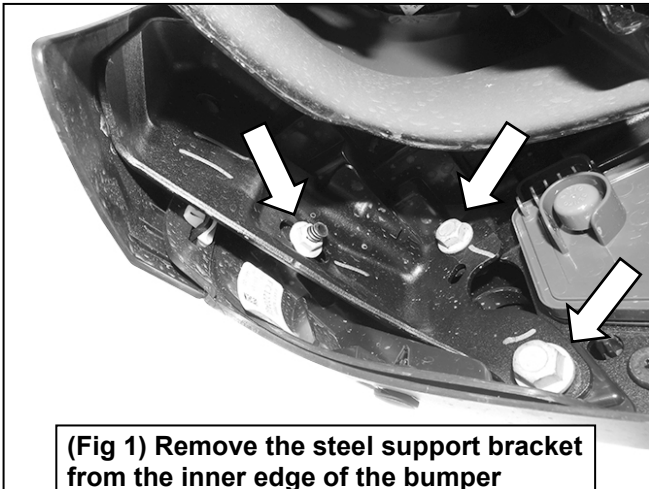

(Fig 1) Remove the steel support bracket from the inner edge of the bumper (Passenger/Right side shown)



(Fig 2) Steel support bracket removed (Passenger/Right side shown)

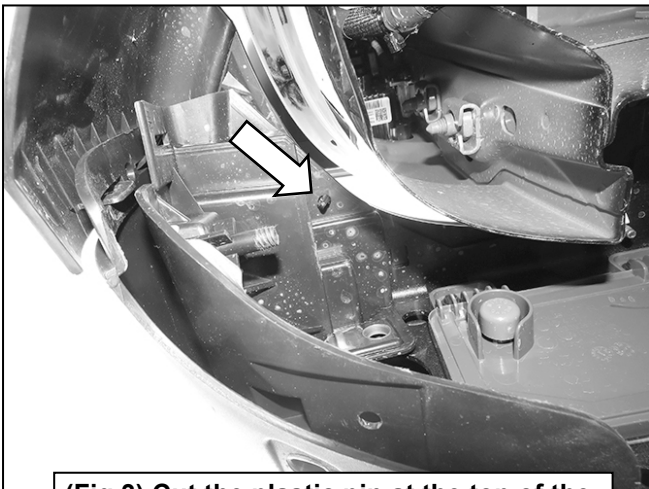

(Fig 3) Cut the plastic pin at the top of the bumper to remove the plastic support bracket (Passenger/Right side shown)

Driver/Left Side Installation Pictured

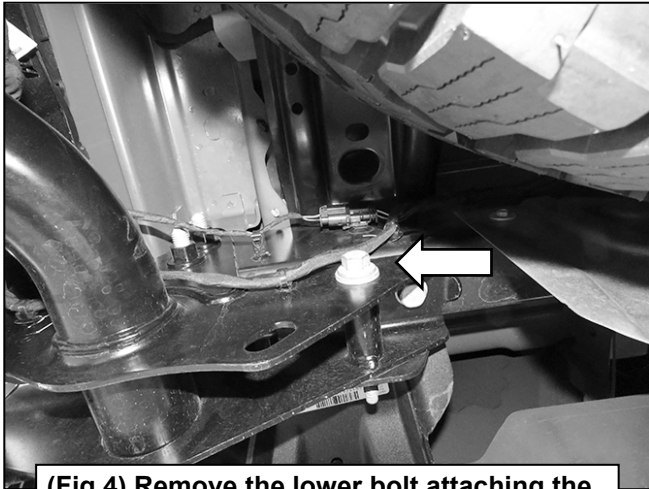

(Fig 4) Remove the lower bolt attaching the bed guard (if equipped) to the receiver hitch

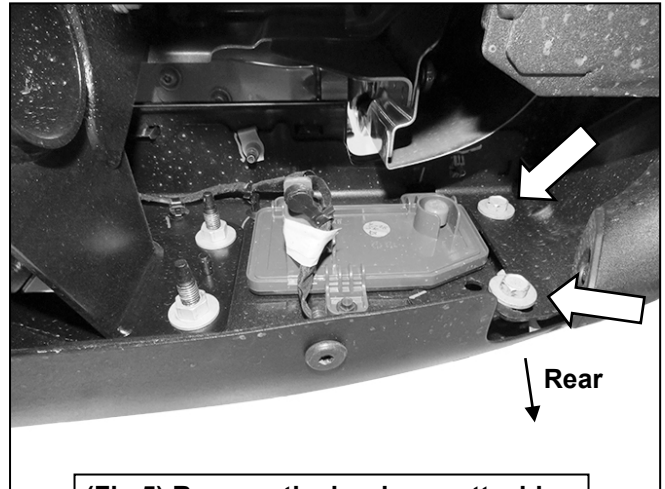

(Fig 5) Remove the hardware attaching the bumper to the bed guards

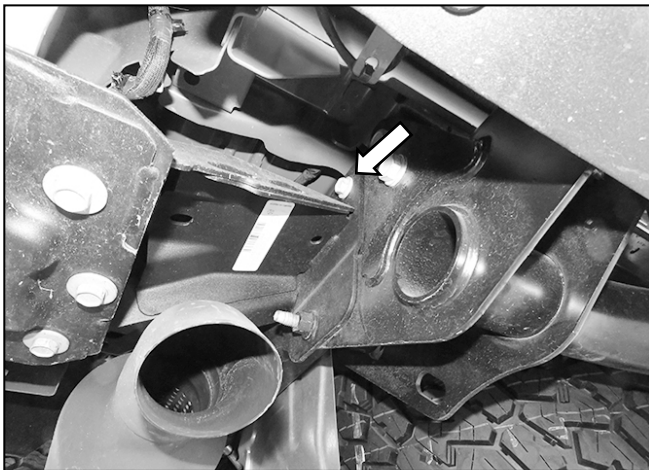

(Fig 6) Remove the (2) upper bolts attaching the bed guard (if equipped) to the receiver hitch



(Fig 7) Bed Guard mounting location (Passenger/Right side shown)

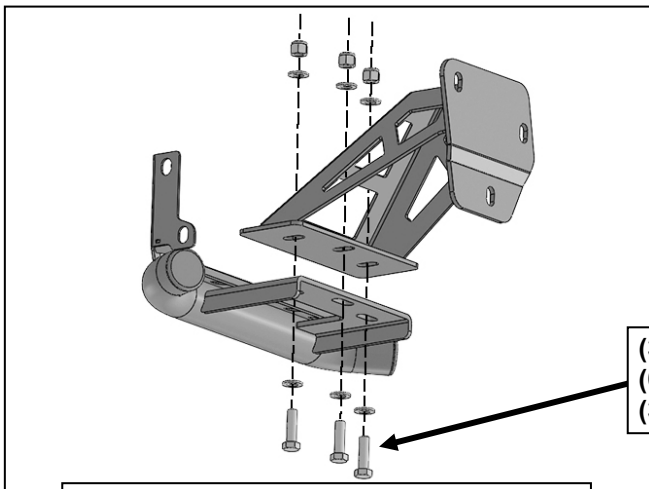

(Fig 8) Attach the Driver/Left Bed Guard to the Driver/Left Mounting Bracket

- (3) 12mm Hex Bolts
- (6) 12mm Flat Washers
- (3) 12mm Nylon Lock Nuts

Driver/Left Side Installation Pictured



(Fig 9) Driver/Left Bed Guard attached to the Driver/Left Mounting Bracket

IMPORTANT: Line up the Bed Guard to the mounting location. Only cut the plastic bumper enough to allow the Bed Guards to mount properly



(Fig 10) Mark the cut line and cut the bottom edge of the factory bumper (Passenger/Right side shown)

- 12mm x 110mm Hex Bolt
- (2) 12mm Flat Washers
- 14mm Spacer Tube
- 12mm Nylon Lock Nut

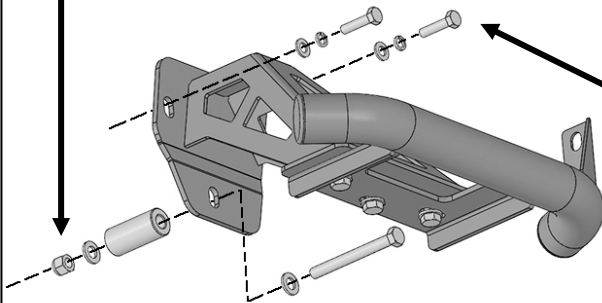

(Fig 11) Attach the Drive/Left Bed Guard assembly to the frame (NOTE: The Spacer Tube is used when the model is not equipped with a receiver hitch)

- (2) 10mm x 40mm Hex Bolts
- (2) 10mm Lock Washers
- (2) 10mm Flat Washers

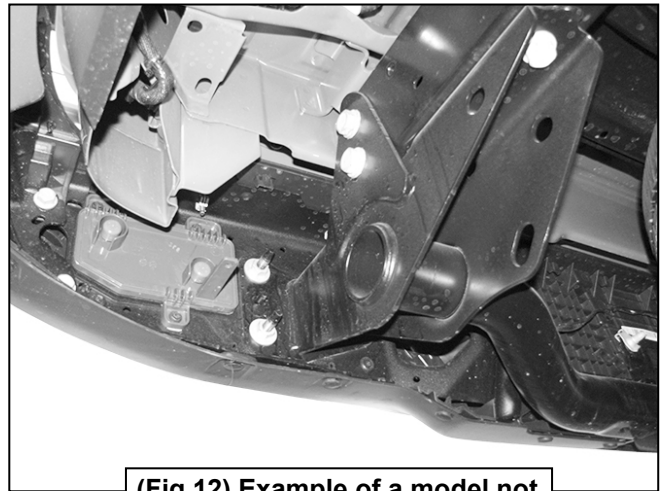

(Fig 12) Example of a model not equipped with a receiver hitch

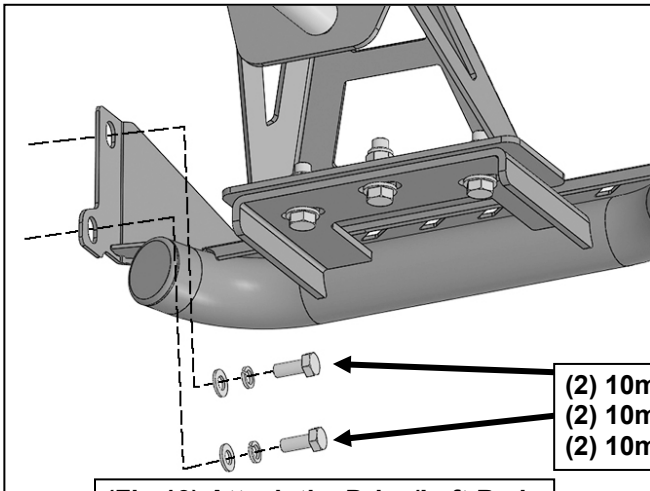

- (2) 10mm x 25mm Hex Bolts
- (2) 10mm Lock Washers
- (2) 10mm Flat Washers

(Fig 13) Attach the Drive/Left Bed Guard assembly to the bumper