

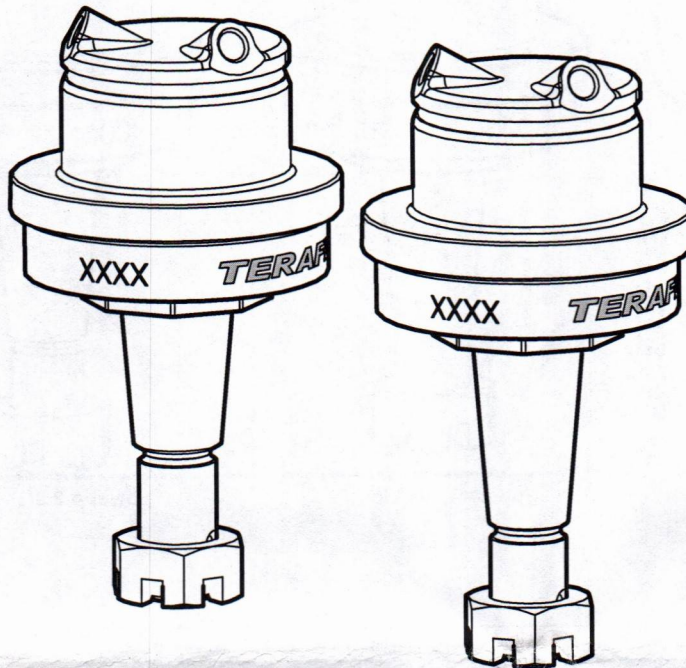

Jeep JL/JT HD Ball Joint Instructions

www.TERAFLEX.com

3452010



Important Notes:

Prior to beginning this install, or any installation, read the instructions thoroughly to familiarize yourself with the required steps. Evaluate if you are experienced and capable to personally perform these modifications. A factory service manual should be used in conjunction with these installation instructions.

This product will change the highway handling characteristics of your vehicle, exercise caution. After altering the suspension it is always advisable to have an alignment done by a competent 4 wheel drive shop or by an alignment shop that is experienced with lifted 4 wheel drive vehicles.

Refer to the parts list to ensure that all necessary components and hardware has been included. If any parts are missing please contact your local TeraFlex dealer for assistance.

When reinstalling OEM hardware, refer to the torque specs given in the Factory Service Manual.

Tools Needed:

- | | |
|--|-----------------------------|
| - Metric Sockets and Open End Wrenches | - Factory Service Manual |
| - Torque Wrench | - General Mechanics Tools |
| - Ball Joint Press | - Large Hammer |
| - Grease Gun / High Quality Grease | - Blue Thread Lock Compound |

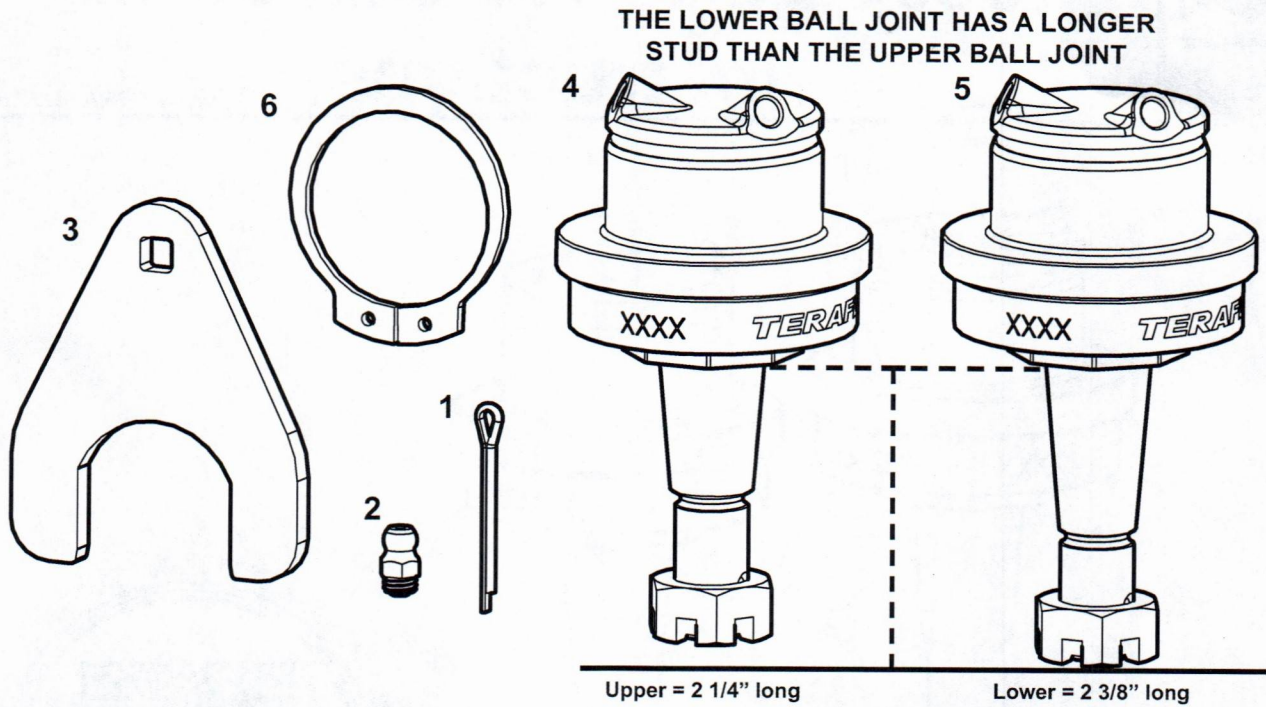

| Item # | Part No. | Description | QTY |
|--------|---------------|--|-----|
| 1 | 301 | Cotter Pin 3/32" Diameter x 1.25" Long | 4 |
| 2 | 308 | Grease Zerk 1/4"-28 UNF Straight, Gold | 8 |
| 3 | 31-02-001-006 | Steering, HD Ball Joint, Jeep JL Wrangler, Adjustment Tool | 1 |
| 4 | 31-02-001-101 | Steering, HD Ball Joint, Jeep JL Wrangler, Upper Ball Joint Assembly | 2 |
| 5 | 31-02-001-201 | Steering, HD Ball Joint, Jeep JL Wrangler, Lower Ball Joint Assembly | 2 |
| 6 | 43-06-02-001 | Retaining Ring, 0.098" Thickness, 42.0mm Shaft Diameter | 2 |

ENGAGE 4 WHEEL DRIVE AND DRIVE JEEP A SHORT DISTANCE

1

LIFT AND SUPPORT AT FRAME

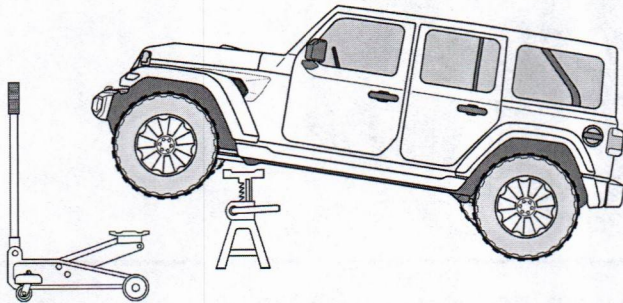

2

REMOVE FRONT WHEELS

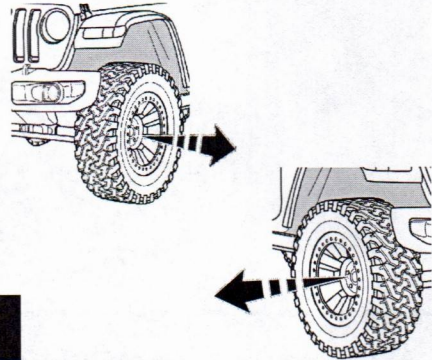

3

DRAIN FRONT DIFFERENTIAL FLUID

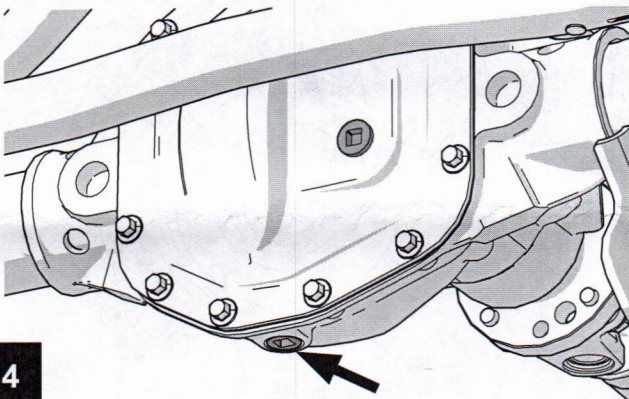

4

REMOVE STABILIZER FROM TIE ROD

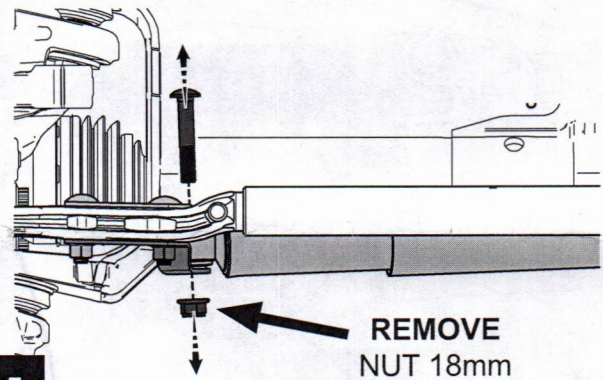

5

DISCONNECT THE DRAG LINK AND TIE ROD FROM THE STEERING KNUCKLES

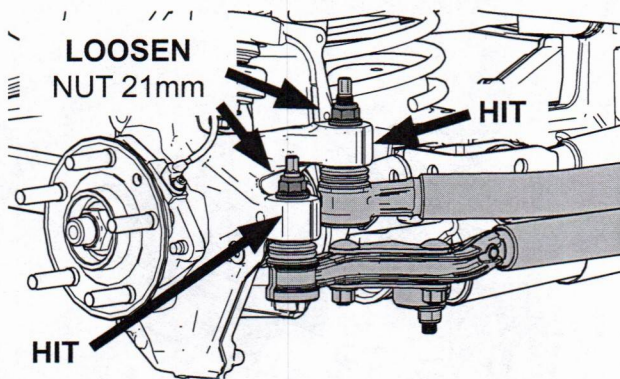

6

ONCE DRAG LINK IS FREE REMOVE FROM KNUCKLE AND TIE UP OUT OF THE WAY.

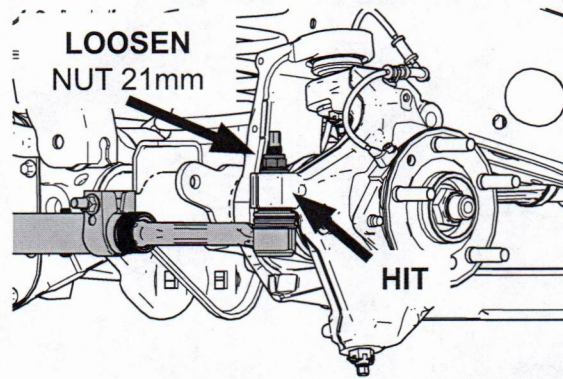

REMOVE BRAKE CALIPER/ANCHOR ASSEMBLIES

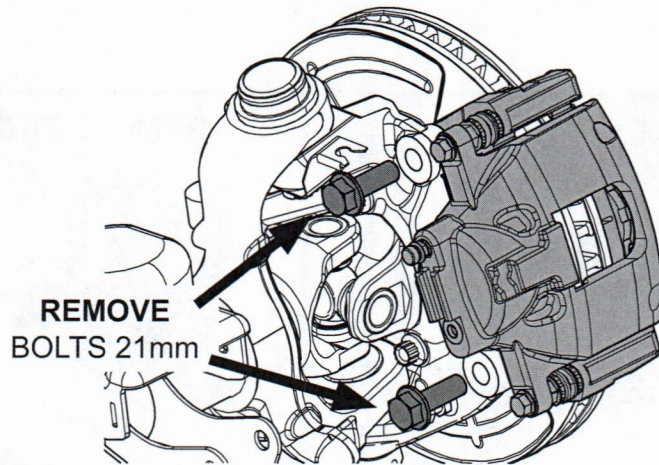

7

REMOVE ROTORS AND SPLASH SHIELDS

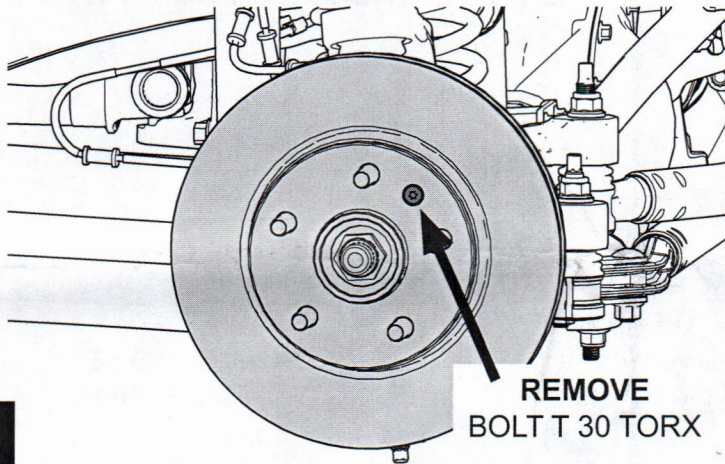

8

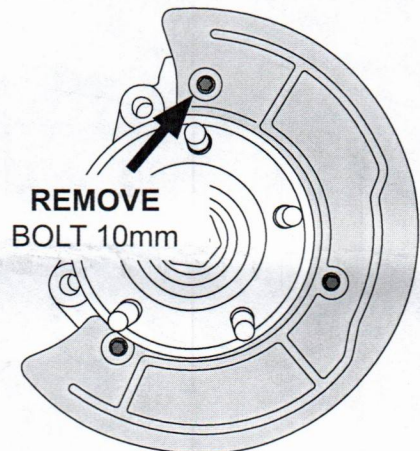

REMOVE THE FRONT WHEEL SPEED SENSORS

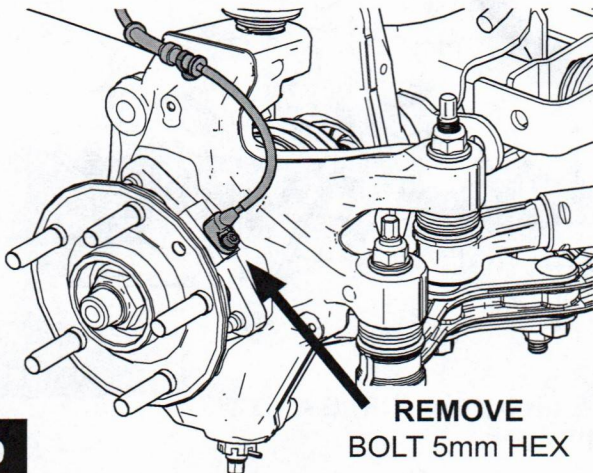

9

REMOVE TRACK BAR AT THE AXLE

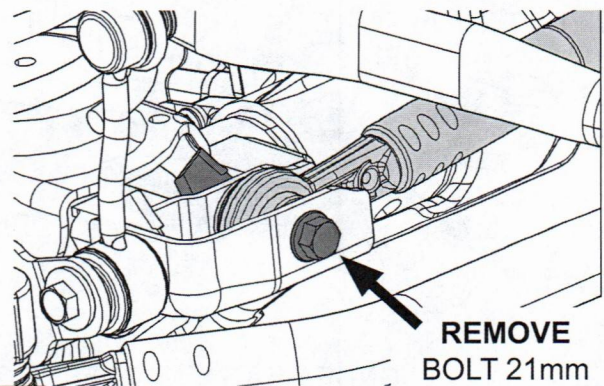

10

LOOSEN THE THREE HUB BEARING BOLTS

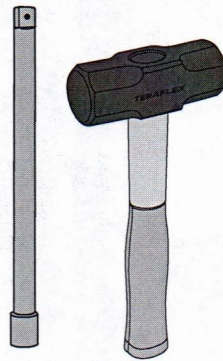
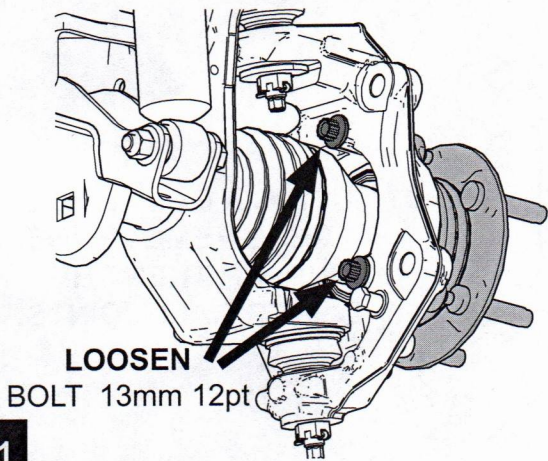

NOTE: HUB BEARING CAN BE SEIZED INTO KNUCKLE AND WILL NEED TO BE FORCED OUT. USE A LONG EXTENSION AND THE 13MM 12 PT SOCKET TO HAMMER ON THE HUB BEARING BOLTS UNTIL HUB BEARING BREAKS FREE.

11

REMOVE HUB BEARING AND AXLE ASSEMBLY

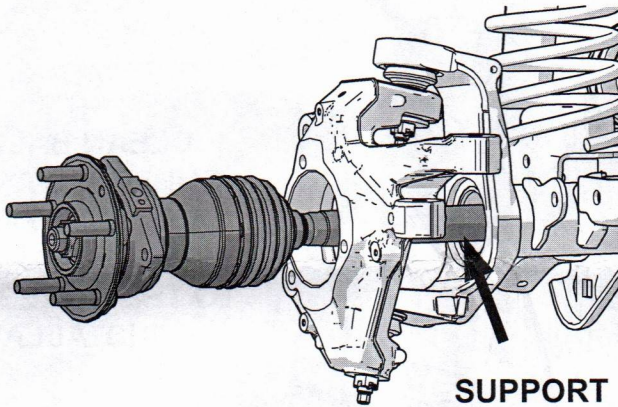

SUPPORT THE INNER AXLE SHAFT SO THAT THE INNER SEAL IS NOT DAMAGED DURING REMOVAL.

12

LOOSEN BALL JOINT NUTS AND REMOVE KNUCKLE

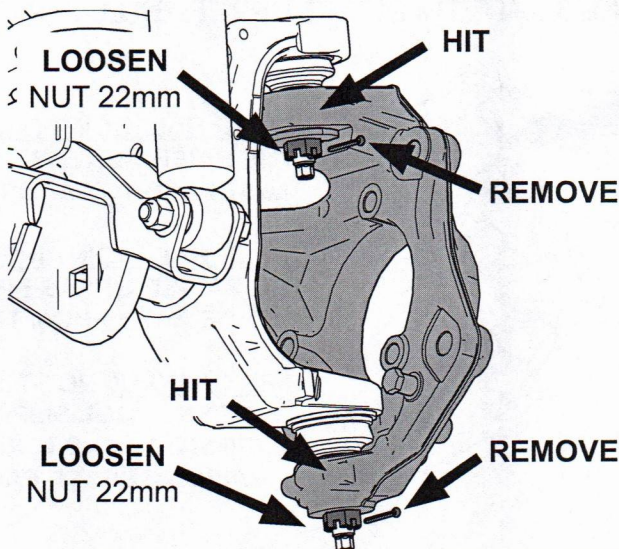

REMOVE COTTER PINS AND LOOSEN UPPER AND LOWER BALL JOINT NUTS BUT DO NOT REMOVE.

USE A LARGE HAMMER OR AIR HAMMER TO REMOVE THE OUTER KNUCKLE.

13

REMOVE THE UPPER THEN THE LOWER BALL JOINTS

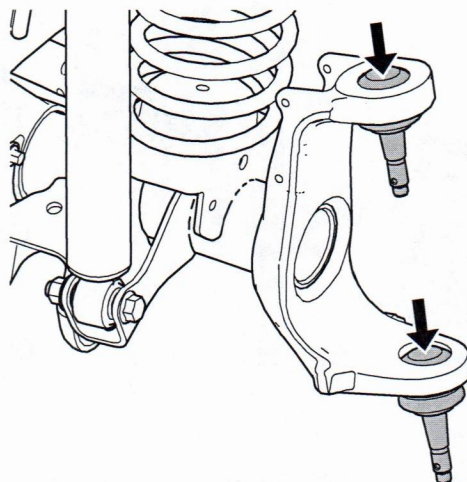

USING A BALL JOINT PRESS REMOVE THE UPPER THEN THE LOWER BALL JOINTS.

14

CLEAN THE BALL JOINT BORES AS WELL AS THE MATING SURFACES

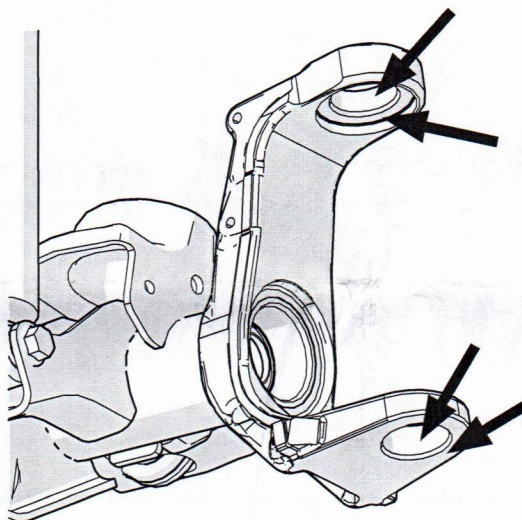

CLEAN BALL JOINT SURFACES AND APPLY A SMALL AMOUNT OF GREASE OR ANTI-SEIZE TO THE BORES TO AID IN INSTALLATION.

15

INSTALL THE LOWER BALL JOINT, THEN THE UPPER BALL JOINT

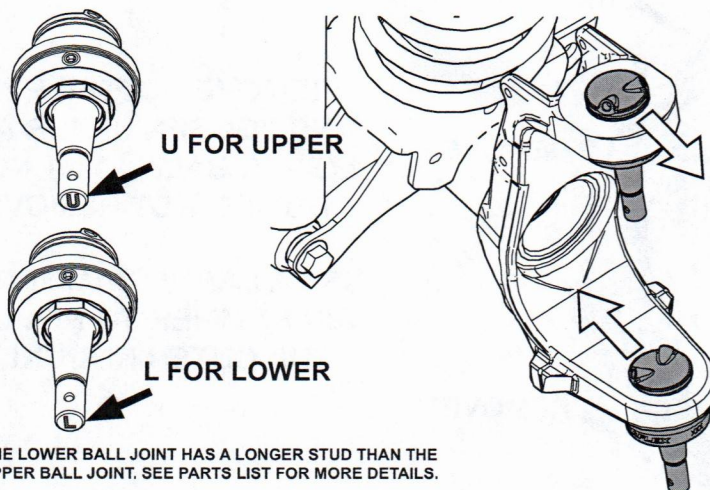

LOWER BALL JOINT INSTALLATION:
THE RAISED GREASE PASSAGES MUST FACE TOWARDS THE AXLE.

UPPER BALL JOINT INSTALLATION:
THE RAISED GREASE PASSEGES FACE AWAY FROM THE AXLE.

BE CAREFUL NOT TO LET THE PRESS TOOL SLIP OUT OF POSITION AND CRUSH THE RAISED GREASE PASSAGES.

16

THE LOWER BALL JOINT HAS A LONGER STUD THAN THE UPPER BALL JOINT. SEE PARTS LIST FOR MORE DETAILS.

**INSTALL RETAINING RINGS ONTO
UPPER BALL JOINT**

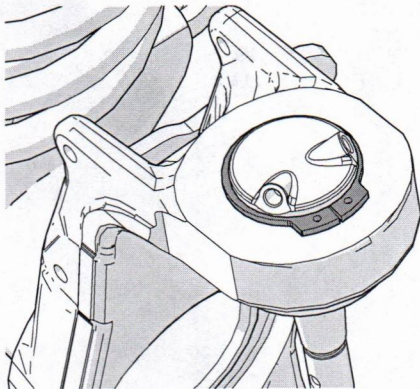

17

**INSTALL GREASE ZERKS AND
GREASE BALL JOINTS**

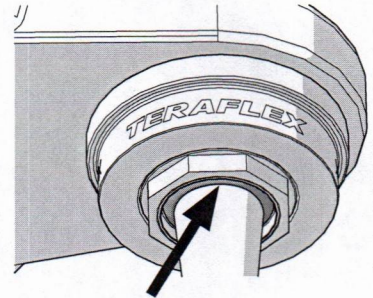
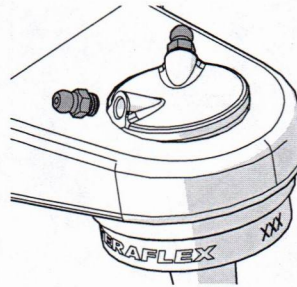

**GREASE UNTIL A SMALL
AMOUNT COMES OUT OF
LIP SEAL**

18

REINSTALL OUTER KNUCKLE

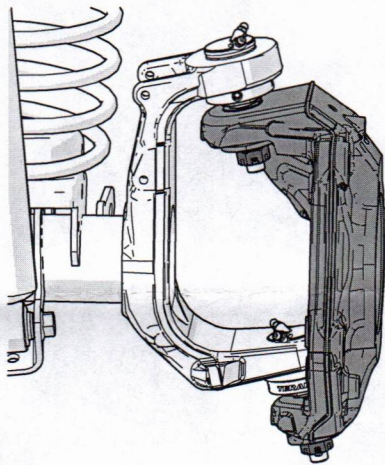

19

**INITIALLY TIGHTEN LOWER BALL JOINT NUT
TO 15 FT-LBS.**

**NEXT TORQUE THE UPPER BALL JOINT NUT
TO 55 FT-LBS. AND INSTALL COTTER PIN.**

**FINALLY TORQUE THE LOWER BALL JOINT TO
33 FT-LBS. AND INSTALL COTTER PIN.**

**NOTE: IF COTTER PIN HOLE DOESN'T LINE UP
TIGHTEN NUT TO NEXT CLOSEST SLOT.**

REINSTALL HUB BEARING/AXLE SHAFT ASSEMBLY

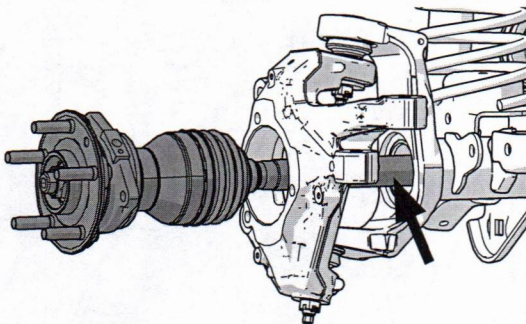

**SUPPORT THE INNER AXLE SHAFT
SO THAT THE INNER SEAL IS NOT
DAMAGED DURING INSTALL.**

20

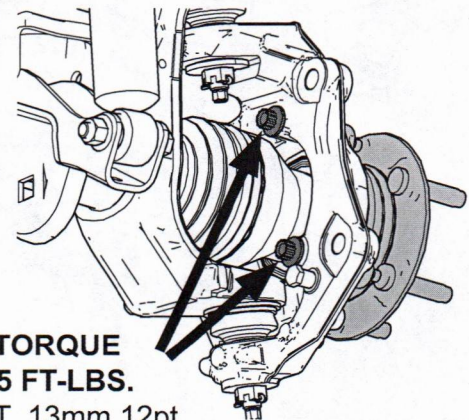

**TORQUE
75 FT-LBS.
BOLT 13mm 12pt**

REINSTALL WHEEL SPEED SENSORS AND SPLASH SHIELDS

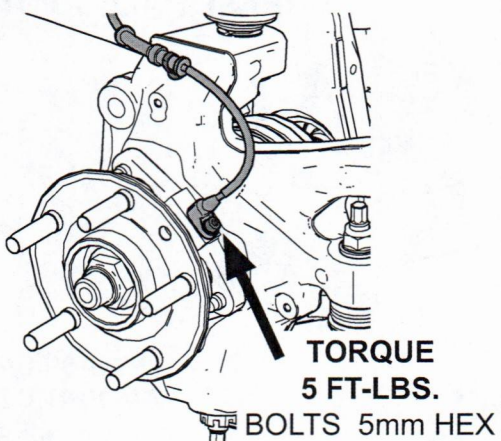

TORQUE 8 FT-LBS. BOLTS 10mm

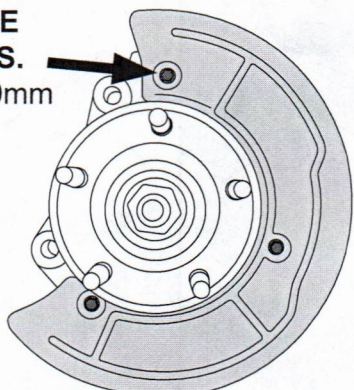

21

REINSTALL ROTORS AND CALIPER ASSEMBLIES

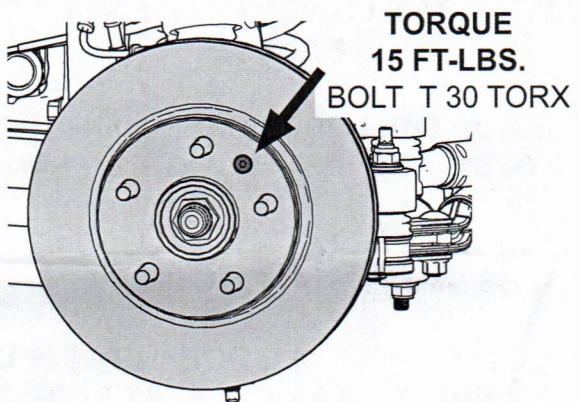

APPLY BLUE THREAD LOCK TO BOLTS

TORQUE 148 FT-LBS. BOLT 21mm

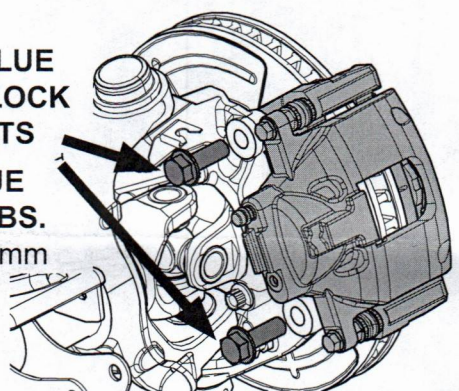

22

REINSTALL DRAG LINK AND TIE ROD

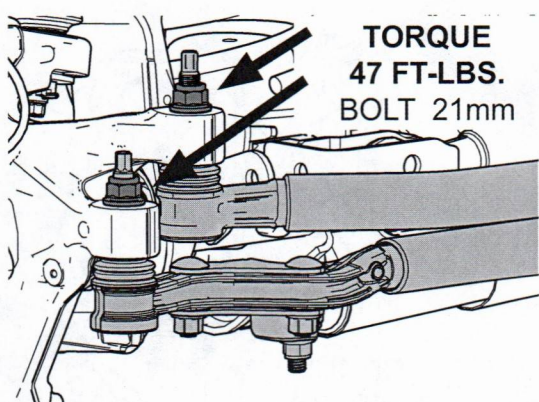

TORQUE 47 FT-LBS. BOLT 21mm

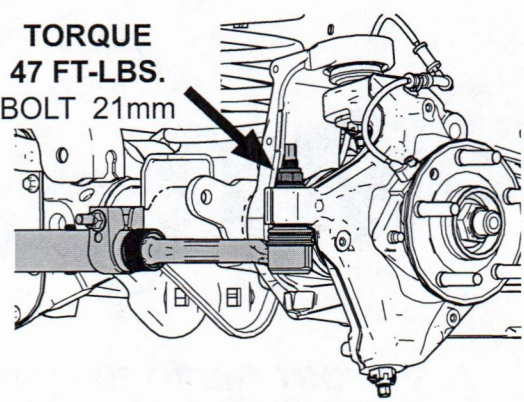

23

REINSTALL STEERING STABILIZER

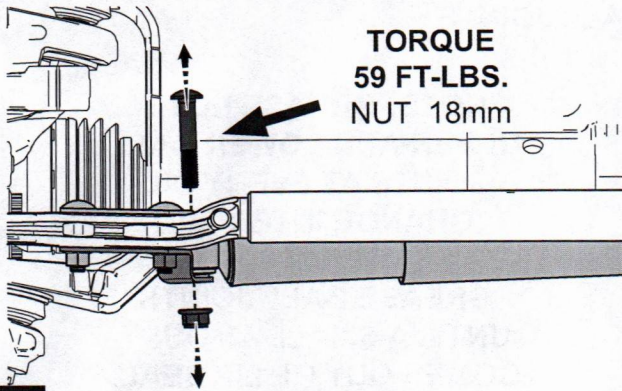

24

REFILL DIFFERENTIAL

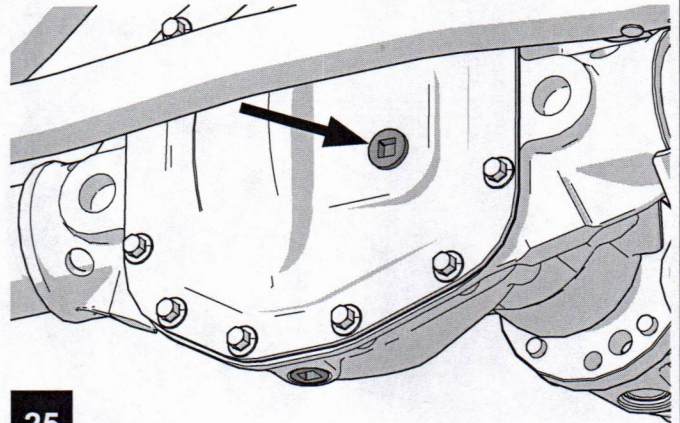

25

REINSTALL WHEELS AND LOWER JEEP TO THE GROUND

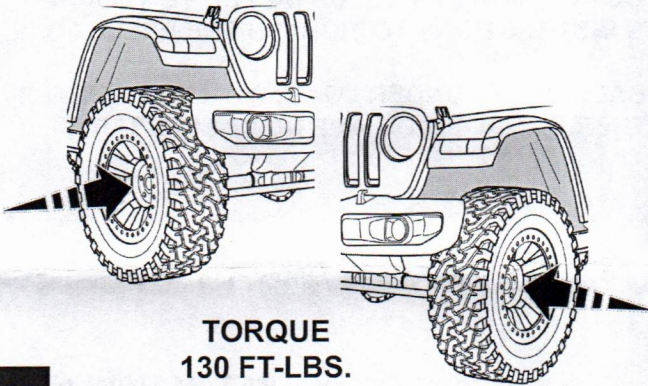

26

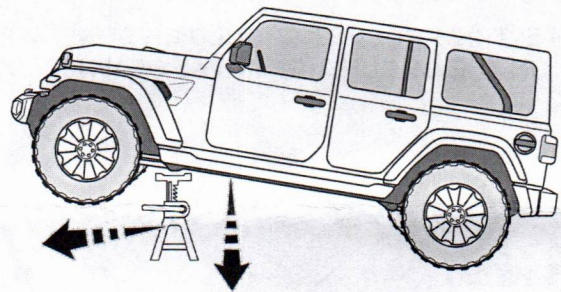

REINSTALL TRACK BAR

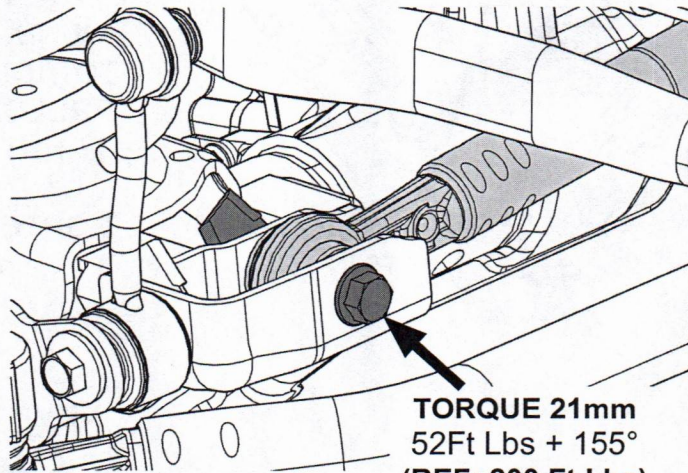

27

SERVICING HEAVY DUTY BALL JOINTS

GREASING THE BALL JOINTS

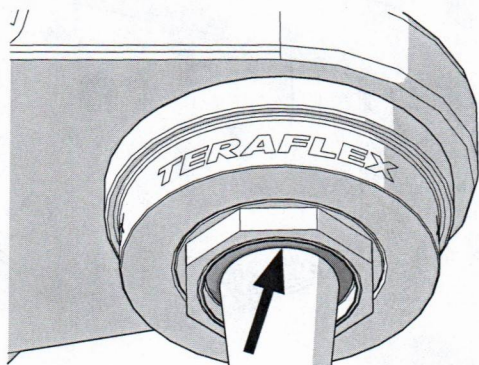

NOTE: GREASE BOTH UPPER AND LOWER BALL JOINTS AT EVERY OIL CHANGE INTERVAL.

GREASE BALL JOINTS UNTIL A SMALL AMOUNT COMES OUT OF LIP SEAL.

SETTING BALL JOINT PRELOAD

NOTE: IF WEAR CAUSES BALL JOINTS TO FALL OUT OF FACTORY SPECS (REFER TO YOUR FACTORY SERVICE MANUAL), USE THE FOLLOWING INSTRUCTIONS TO TIGHTEN THE PRELOAD.

NOTE: THIS PROCESS SHOULD BE DONE WITH THE BALL JOINTS UNDER LOAD, WITH THE WHEELS ON THE GROUND. REMOVAL OF WHEELS AND OTHER COMPONENTS ARE NOT NECESSARY.

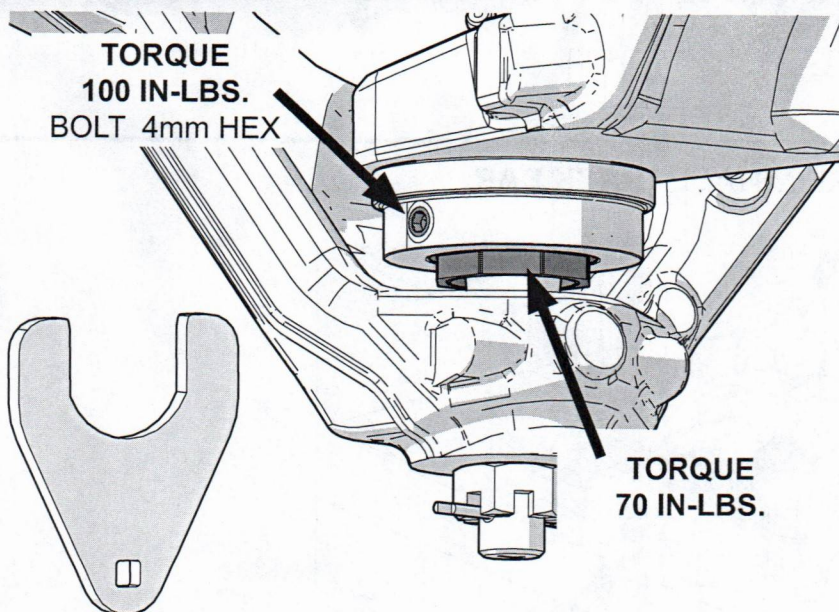

LOOSEN SET SCREW AT BASE OF BALL JOINT.

USE SUPPLIED SPECIALTY WRENCH AND AN INCH POUND TORQUE WRENCH TO TIGHTEN BALL JOINT PRELOAD ADJUSTMENT NUT TO 70 IN-LBS.

TIGHTEN SET SCREW TO 100 IN-LBS.

TERAFLEX

PRODUCT INFORMATION

MAINTENANCE INFORMATION:

It is the buyer's responsibility to have all suspension, drivetrain, steering, and other components checked for proper tightness and torque after the first 100 miles and every 3000 miles after that.

NOTICE TO INSTALLER:

The enclosed "Warning to Driver" sticker must be installed in the vehicle in driver's view. This sticker is to act as a constant safety reminder when operating the vehicle. It is your responsibility as the equipment installer to install the provided sticker and to forward the product instructions to the vehicle's owner for review. If a "Warning to Driver" sticker or product installation guide were not included in the kit, FREE replacement stickers and instructions are available by request. It is the installer's duty to ensure a safe and controllable vehicle after the modifications have been performed.

WARNING:

Neither the seller nor the manufacturer will be liable for any loss, damage, or injury directly or indirectly arising from the use of or inability to determine the use of these products. Before using, the user shall determine the suitability of the products for its intended use, and the user shall assume all responsibility and risk in connection therewith.

WARNING TO DRIVER:

This vehicle has been modified to enhance off road performance and has unique handling characteristics. Use in harsh environments can cause extreme stress on the components. Vehicle should be inspected after being off road to make sure that all the components are in working order and safe to travel on the highway. All fasteners should be checked so that they are at the correct torque specifications as the vibration and stresses from off roading may cause critical fasteners to work loose. Extra care should be taken to inspect the critical components, steering, and brake systems. During each oil change components such as arms, tie rod ends, etc should be greased and checked for excessive wear. Any worn components should be replaced. When returning to the pavement always set or restore tire air pressure to the factory recommendation and connect or engage any disabled sway bar mechanisms. Because of the higher center of gravity and larger tires, this vehicle handles and reacts differently than many passenger cars, both on and off road. You must drive it safely! Extreme care should be taken to prevent vehicle rollover or loss of control, which can result in serious injury or death. Avoid sudden sharp turns or abrupt maneuvers. Generally, braking performance and capabilities are decreased when significantly larger/heavier tires are used, especially when used in combination with transfer case low-range reduction kits. Take this into consideration while driving. Do not add, alter or fabricate any factory or aftermarket parts to increase vehicle height over the intended height of the TeraFlex product purchased. Mixing component brand is not recommended. TeraFlex Inc. will not be responsible for any altered product or any improper installation or use of our products. We will be happy to answer any questions concerning the design, function, and correct use of our products. It is ultimately the buyer's responsibility to have all bolts/nuts checked for tightness after the first 100 miles and then every 3000 miles. Wheel alignment, steering system, suspension and drive line systems must be inspected by a qualified professional mechanic at least every 3000 miles.

TERAFLEX PRODUCT WARRANTY:

TeraFlex Inc. warrants TeraFlex Suspension products to the original retail purchaser to be free of defects in material and workmanship for as long as the original purchaser owns the vehicle on which products were originally installed.

Failure to complete regular maintenance (grease every 3000 miles) on TeraFlex FlexArms will void this warranty. All other conditions of the standard TeraFlex product warranty apply.

All TeraLow products are covered by the TeraFlex two (2) year warranty to be free of defects in material and workmanship for two years from date purchased.

TeraFlex axles are covered by a 12-month warranty to be free of defects in materials and workmanship.

This warranty does not cover or include product finish, improperly installed or applied products, improperly maintained products, products or components used for racing or competition or damage due to abuse or neglect, products that fail due to the use of larger tire and wheel combinations.

All returns must be accompanied by an original invoice. It is the customer's responsibility to remove the product from the vehicle. Shipping charges are the responsibility of the customer. TeraFlex Inc. will pay the return freight if the product meets the terms of warranty.

This warranty is for the replacement or repair of defective TeraFlex products only and does not include freight charges, labor charges for removal of or installation of TeraFlex or related products or components, costs incurred due to down time of the vehicle, or lost profits due to vehicle down time.

A returned goods authorization number (RGA#) must accompany any returned products. For more information please contact a TeraFlex customer service representative.

COPYRIGHT

©Copyright 2014. All rights reserved, TeraFlex Inc. Reproduction of this catalog and/or any of its contents without written permission is strictly prohibited.

TeraFlex® is a registered trademark of TeraFlex Inc. All trade names and logos including but not limited to TeraFlex, FlexArms, RockGuard, Monster, and LCG are protected by law and duplication of trade names and/or logos are strictly prohibited.

TeraFlex Inc. reserves the right to update, discontinue, redesign, modify finish, part number or component build parts if deemed necessary without written notice. TeraFlex Inc., and any associated dealers are not responsible for misprints or typographical errors that may have inadvertently been made within this instruction sheet.

Jeep® and the Jeep® grill are registered trademarks of Fiat Chrysler Automobiles N.V., and have no affiliation with TeraFlex Inc.

TERAFLEX, Inc.

5680 West Dannon Way
West Jordan, UT. 84081
Phone/801.713.3314
Fax/801.713.2313
www.teraflex.com