



## **INSTALLATION INSTRUCTIONS**

**3-1/2" LED BULL BAR  
2020-2023+ GLADIATOR JT**

**PARTS LIST:**

1	3.5in Oval Bull Bar	4	10-1.50mm x 35mm Hex Bolts
2	Mounting Brackets	2	10mm Plastic Retainers
1	Driver/Left Frame Mounting Bracket	4	10mm x 30mm x 2.5mm Flat Washers
1	Passenger/Right Frame Mounting Bracket	4	10mm Lock Washers
1	20" LED Light Bar	2	10-1.50mm Hex Nuts
4	12-1.75mm x 35mm Hex Bolts	4	8-1.25mm x 35mm Hex Bolts
8	12mm x 32mm OD x 3mm Flat Washers	2	8mm x 16mm Hex Bolts
4	12mm Lock Washers	6	8mm Lock Washers
4	12-1.75mm Hex Nuts	6	8mm x 24mm x 2mm Flat Washers
2	10-1.50mm x 40mm Bolt-Nut Plates		

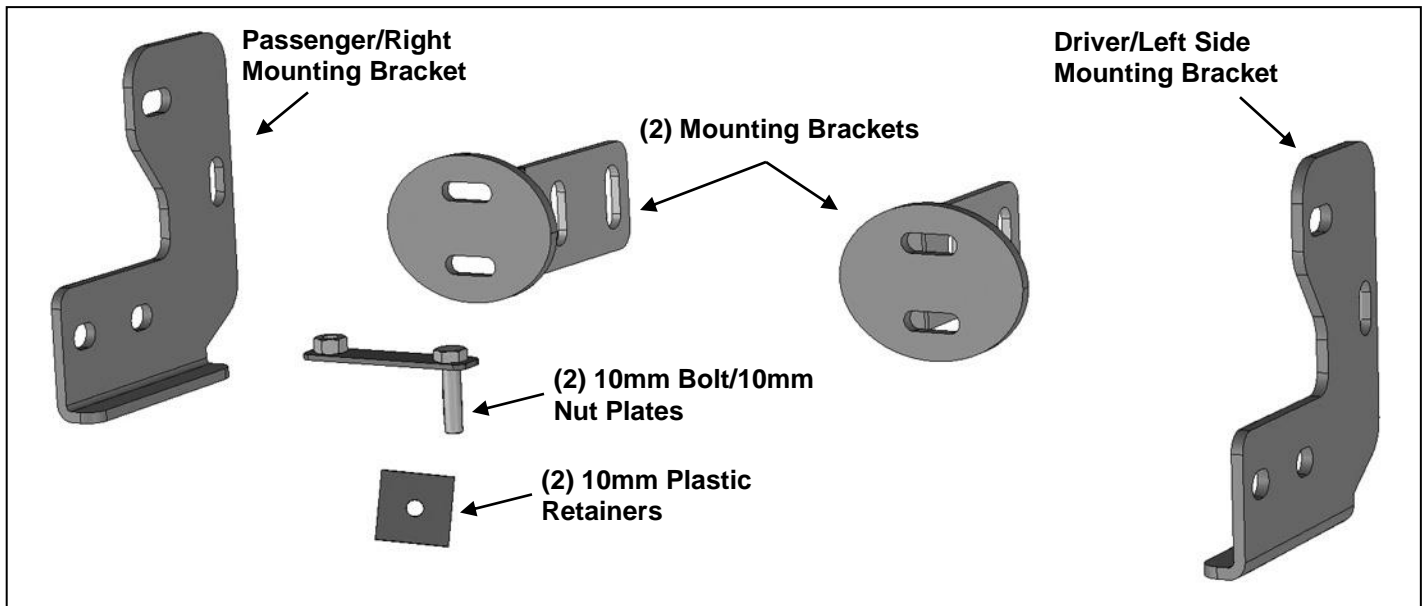

**PROCEDURE:**

**PROCEDURE: REMOVE CONTENTS FROM BOX. VERIFY ALL PARTS ARE PRESENT. READ INSTRUCTIONS CAREFULLY. CUTTING IS REQUIRED. ASSISTANCE IS RECOMMENDED.**

1. Remove the plastic splash guard from under the front bumper and place it on a clean, stable work surface, **(Figures 1 & 6)**. Models with steel skid plate, skid plate must be removed and cannot be reinstalled.

**Models with plastic splash guard:**

- a. Starting on the passenger/right side, locate the lower hex shaped hole in the outside of the frame, **(Figure 2)**. Insert (1) 10mm Bolt/Nut Plate, (end with welded nut first), into the open end of the bottom of the frame and push the welded hex bolt through the hex shaped hole, **(Figure 3)**. Thread (1) 10mm Plastic Retainer onto the Bolt/Nut Plate to hold it in position. **NOTE:** Plastic Retainer is designed to hold the Bolt Plate in position to help with Bracket installation. Use is not mandatory. **IMPORTANT:** Temporarily remove the steel frame bracket for the splash guard if more room is necessary to install the Bolt/Nut Plate, **(Figure 1)**.
- b. Select the passenger/right side Frame Mounting Bracket, **(Figure 4)**. Attach the Bracket to the Bolt on the Bolt Nut Plate with (1) 10mm Flat Washer, (1) 10mm Lock Washer and (1) 10mm Hex Nut. Leave loose at this time. Grab the threaded end of the 10mm Bolt/Nut Plate and rotate it until the top end with the welded Nut lines up with the round hole in the outside of the frame and the top mounting hole in the Bracket. Attach the Bracket to the Bolt/Nut Plate with (1) 10mm x 35mm Hex bolt, (1) 10mm Lock Washer and (1) 10mm Flat Washer, **(Figures 4 & 5)**. Snug but do not fully tighten Bracket hardware at this time. Reinstall the steel frame bracket for the splash guard if previously removed.

**Models with steel skid plate:**

- a. Select the passenger/right side Frame Mounting Bracket. Attach the Bracket to the lower threaded hole in the outside of the frame with (1) 10mm x 35mm Hex bolt, (1) 10mm Lock Washer and (1) 10mm Flat Washer, **(Figure 4)**. Do not tighten.
- b. Repeat the previous Steps to install the Bolt/Nut Plate into the open end of the frame and up to the top mounting hole, **(Figure 3)**. Attach the top of the Bracket to the Nut end on the Bolt /Nut Plate with (1) 10mm x 35mm Hex bolt, (1) 10mm Lock Washer and (1) 10mm Flat Washer, **(Figures 4 & 5)**. Snug but do not fully tighten Bracket hardware at this time.
2. Repeat the appropriate **Step 2** for driver/left side Mounting Bracket installation.
3. Position the splash guard back up to the vehicle and temporarily attach with the factory hardware. Trace the location of the Mounting Brackets onto the back of the splash guard, **(Figure 6)**. Remove the splash guard and move it to a clean stable work surface. Carefully cut openings in the splash guard to clear the Frame Brackets. **NOTE:** To maintain the integrity of the plastic Splash Guard, remove only material necessary to clear the Brackets. Make small cuts and check the fit often during installation.
4. Reinstall the steel bracket, (if removed-see **Fig. 1**), and splash guard.
5. Next, select (1) Mounting Bracket, **(Figure 7)**. Attach the Bracket to the end of the tube on the Bull Bar with the included (2) 8mm x 35mm Hex Bolts, (2) 8mm Lock Washers and (2) 8mm Flat Washers, **(Figures 7 & 8)**. Do not fully tighten hardware at this time. Repeat this Step to attach the driver/left Tube Mounting Bracket.
6. **Center LED Light Installation, (LED Light Bar Included):**
  - a. Attach the LED Light Bar to the back of the Bull Bar using the included (2) 8mm x 16mm Hex Bolts, (2) 8mm Lock Washers and (2) 8mm x 24mm Flat Washers, **(Figure 9)**.
7. With assistance, line up the Brackets on the Bull Bar with the outside of the Frame Brackets. Attach the Tube Brackets to the Frame Brackets with the included (4) 10mm x 35mm Hex Bolts, (8) 10mm Flat Washers, (4) 10mm Lock Washers and (4) 10mm Hex Nuts, **(Figures 10 & 11)**. Snug but do not tighten hardware at this time.
8. Level and adjust the Bull Bar and tighten all hardware.
9. Do periodic inspections to the installation to make sure hardware is secure and tight.

**To protect your investment**, wax this product after installing. Regular waxing is recommended to add a protective layer over the finish. Do not use any type of polish or wax that may contain abrasives that could damage the finish.

**For stainless steel:** Aluminum polish may be used to polish small scratches and scuffs on the finish. Mild soap may be used also to clean the Bull Bar.

**For gloss black finishes:** Mild soap may be used to clean the Bull Bar.

### Passenger/right Side Installation Pictured



**(Fig 1) Remove splash guard and bracket (arrow)**

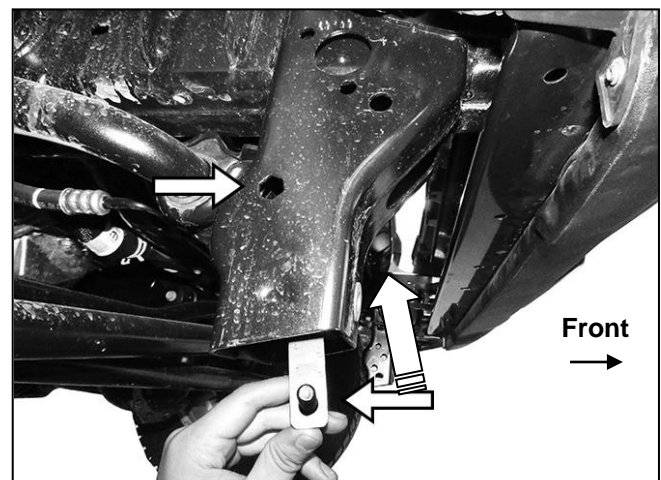

**(Fig 2) Insert 10mm Bolt/Nut Plate into bottom of frame and out hex hole in side of frame (arrows)**

### Passenger/right Side Installation Pictured

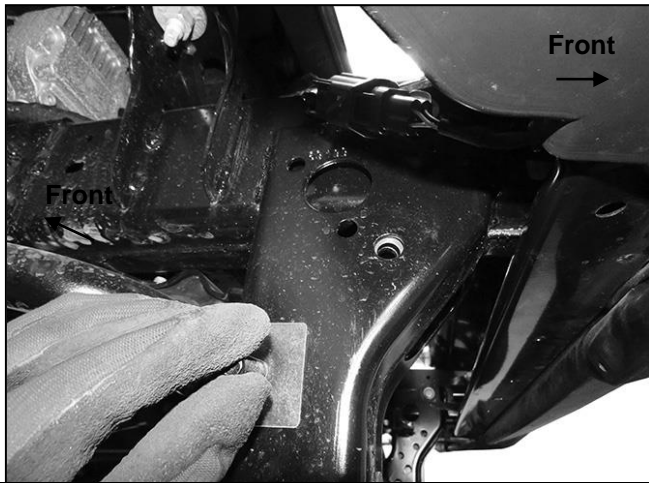

(Fig 3) Use Retainer to hold 10mm Bolt/Nut Plate. Rotate Bolt/Nut Plate to line up Nut with factory hole

Models with plastic splash guard  
10mm Hex Nut  
10mm Lock Washer  
10mm Flat Washer

10mm x 35mm Hex Bolt  
10mm Lock Washer  
10mm Flat Washer

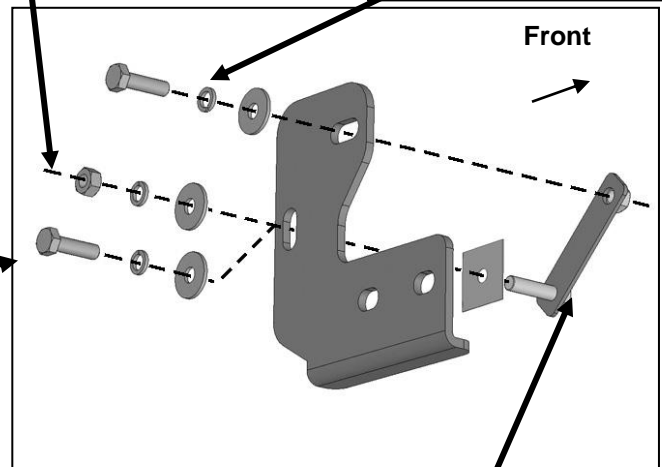

(Fig 4) Attach passenger/right Frame Mounting Bracket to 10mm Bolt/Nut Plate and Retainer

Models with steel skid plate use  
10mm Hex Nut  
10mm Lock Washer  
10mm Flat Washer

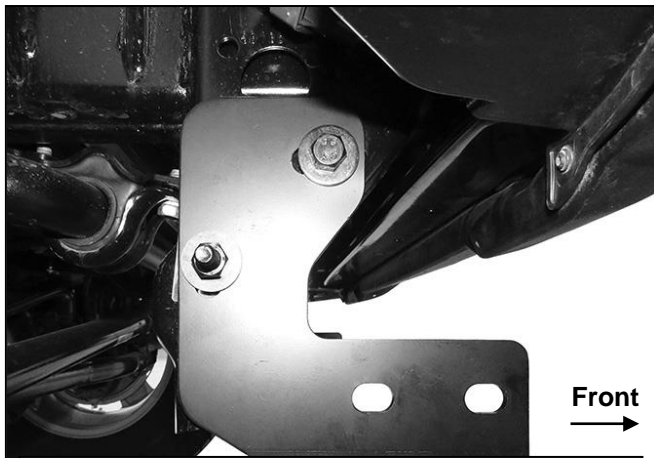

(Fig 5) Passenger/right Frame Bracket installed

Cut two openings to clear the Mounting Brackets

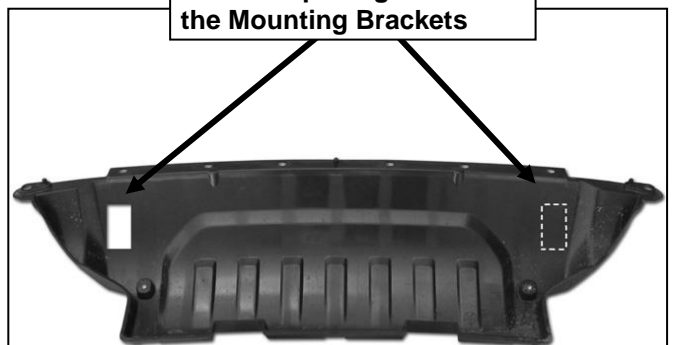

Area to cut from splash guard illustrated for example only.

Fig 6

### Passenger/right Side Installation Pictured

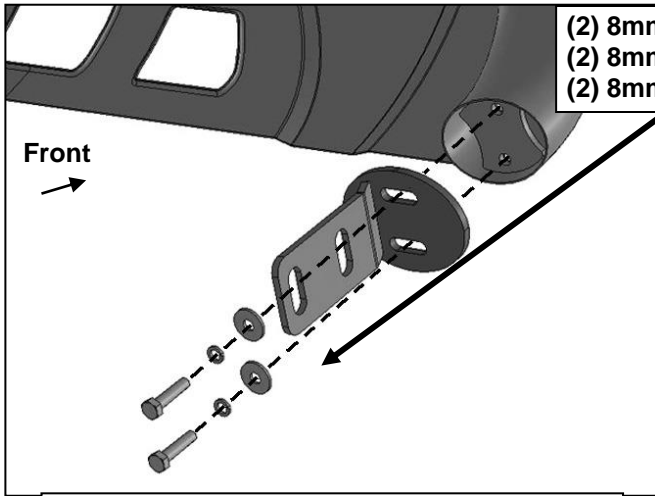

(Fig 7) Attach Mounting Bracket to end tube

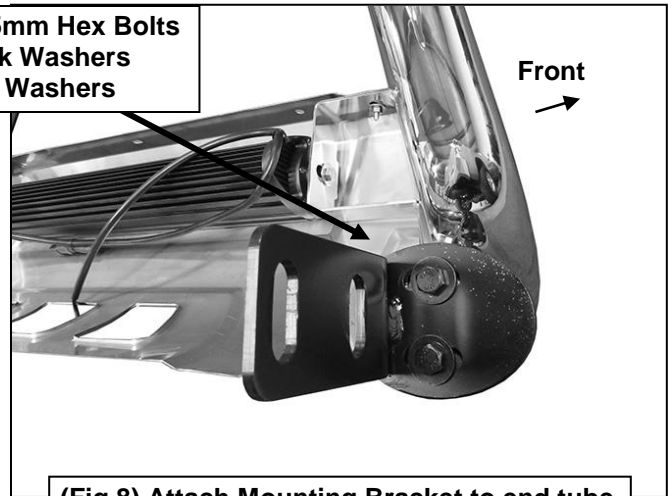

(Fig 8) Attach Mounting Bracket to end tube

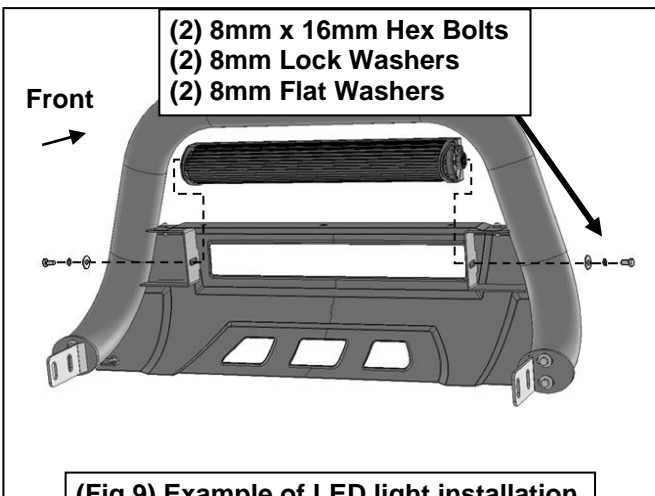

(Fig 9) Example of LED light installation

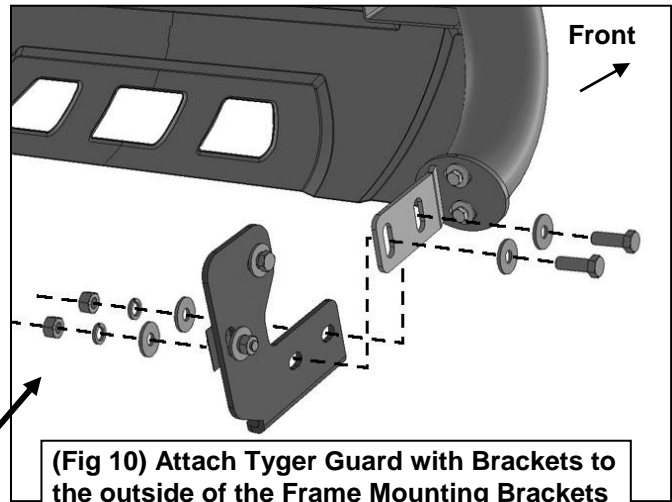

(Fig 10) Attach Tyger Guard with Brackets to the outside of the Frame Mounting Brackets

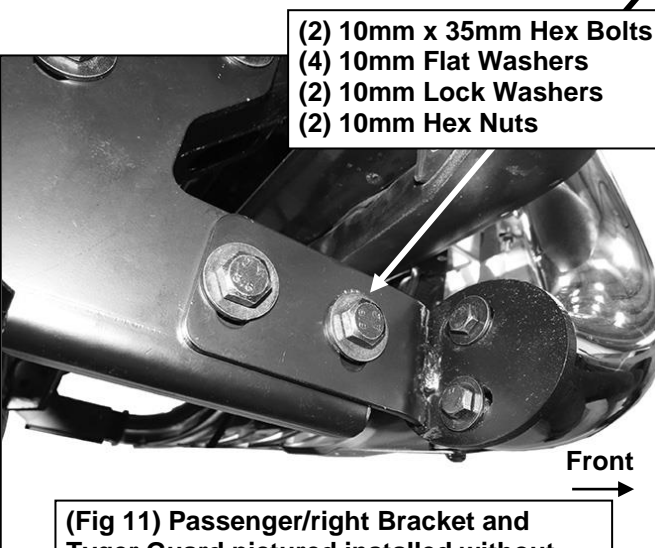

(Fig 11) Passenger/right Bracket and Tyger Guard pictured installed without splash guard for instruction purposes

