

REDROCK

INSTALLATION INSTRUCTIONS

**GRILLE GUARD – Gloss Black
2020-2023+ GLADIATOR JT**

PARTS LIST:

1	2018 Wrangler JL Grille Guard	4	10-1.5mm x 30mm Hex Bolts
1	Driver/left Mounting Bracket	4	10mm Lock Washers
1	Passenger/right Mounting Bracket	4	10mm x 30mm x 2.5mm Flat Washers
1	Driver/left Support Bracket	2	8-1.25mm Bolt-Nut Plates
1	Passenger/right Support Bracket	4	8-1.25mm x 30mm Hex Bolts
1	Driver/left side Splash Guard Bracket	2	8-1.25mm x 25mm Button Head Bolts
1	Passenger/right side Splash Guard Bracket	2	8mm Plastic Retainers
6	12-1.75mm x 35mm Hex Bolts	12	8mm x 24mm x 2mm Flat Washers
12	12mm x 24mm x 2.5mm Flat Washers	4	8mm Lock Washers
6	12mm Lock Washers	2	8-1.25mm Hex Nuts
6	12-1.75mm Hex Nuts	4	8-1.25mm Nylon Lock Nuts

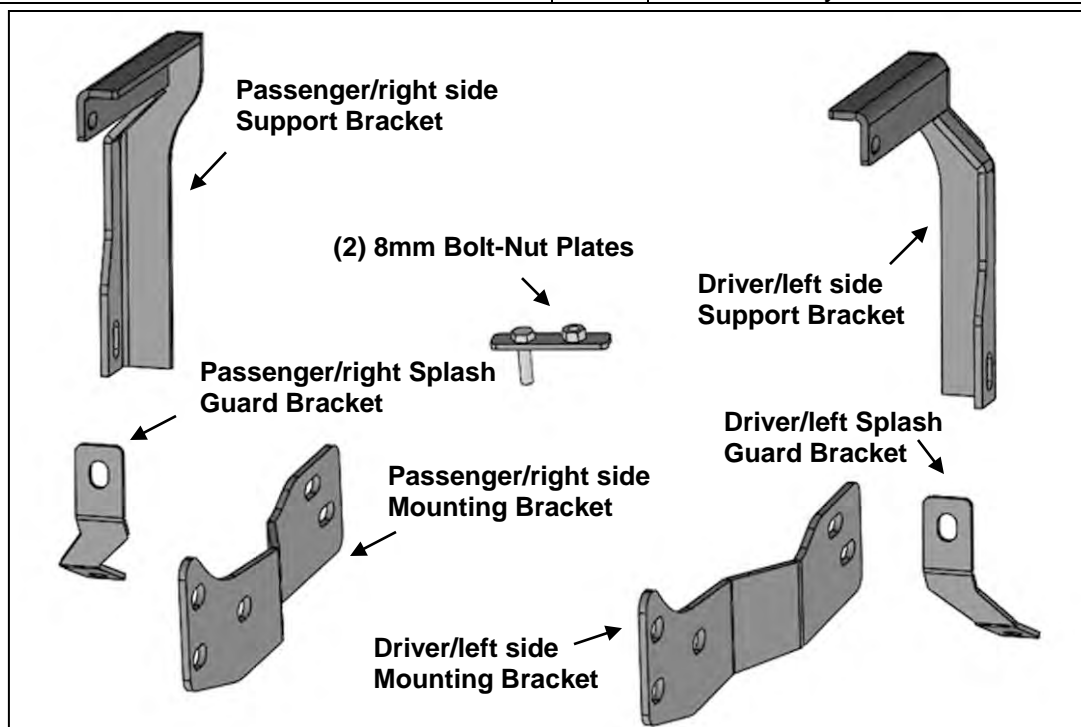
**PROCEDURE:**

1. REMOVE CONTENTS FROM BOX. VERIFY ALL PARTS ARE PRESENT. READ INSTRUCTIONS CAREFULLY BEFORE STARTING INSTALLATION. CUTTING IS REQUIRED. ASSISTANCE IS RECOMMENDED.

2. Starting from underneath the front bumper, remove the plastic lower splash guard, **(Figure 1)**. Also, remove the metal plate behind the plastic splash guard, **(Figure 2)**. From the top of the front bumper, remove the plastic fill panel between the front bumper and grille, **(Figure 3)**.

3. Starting on the driver/left side of the frame, determine if the frame is equipped with threaded inserts.

Models with (2) hexagonal holes in the frame:

- Insert (1) 8mm Bolt-Nut Plate in through the bottom opening of the frame and push the Bolt on the Bolt-Nut plate out through the hexagonal hole on the inside of the frame, **(Figure 4A)**. Thread (1) 8mm Plastic Retainer onto the Bolt on the Bolt-Nut Plate to keep the Plate in place. Align the Nut on the Bolt-Nut Plate to the adjacent hexagonal hole, **(Figure 4B)**. **NOTE:** The Plastic Retainer is used to prevent the Bolt-Nut Plate from falling and help in Mounting Bracket installation.
- Select the Driver/left side Mounting Bracket. Attach the Bracket to the Bolt on the Bolt-Nut Plate using (1) 8mm Flat Washer, (1) 8mm lock Washer and (1) 8mm Hex Nut, **(Figures 5 & 7)**. Attach the Bracket to the Nut on the Plate with (1) 8mm Hex Bolt, (1) 8mm Lock Washer and (1) 8mm Flat Washer, **(Figures 5 & 7)**. Do not tighten hardware at this time.
- Repeat the previous steps to install the passenger/right side Mounting Bracket.

Models with threaded inserts:

- a. Select the Driver/left side Mounting Bracket, **(Figure 6)**. Attach the Bracket to the threaded holes on the inside of the frame using the provided (2) 10mm Hex Bolts, (2) 10mm Lock Washers and (2) 10mm Flat Washers, **(Figure 6)**. Do not tighten hardware at this time
- b. Repeat the previous step to install the passenger/right side Mounting Bracket.
4. Move to the top of the driver/left side of the frame to install the Support Bracket. Locate and remove the long factory bolt going through the bumper bracket and frame, **(Figure 8)**. **WARNING! DO NOT** remove both factory bolts at once or bumper may fall. Install one side at a time to avoid possible injury or damage to vehicle. Select the Driver/left side Support Bracket. Reuse the long factory bolt to attach the Support Bracket to the inside of the frame, **(Figure 9)**. Snug but do not tighten hardware.
5. Repeat **Step 4** to install the passenger/right side Support Bracket.
6. With assistance, lift the Grille Guard up to the outside of the Mounting Brackets. Line up the holes in the Mounting Brackets with the holes in the Grille Guard. Attach the Grille Guard to the Mounting Brackets with (6) 12mm Hex Bolts, (12) 12mm Flat Washers and (6) 12mm Nylon Lock Nuts, **(Figures 10 & 11)**. Push the grille guard back into an upright position. Secure the Support Brackets to the inside of the grille guard with the included (2) 10mm Button Head Bolts, (4) 10mm Flat Washers and (2) 10mm Nylon Lock Nuts, **(Figures 12 & 13)**. Snug but do not tighten all of the hardware.
7. Stand back from the vehicle and check to see that the Grille Guard is centered and level on the vehicle and adjust as required. It may be necessary to slightly loosen the Mounting Brackets to properly align the Grille Guard. **IMPORTANT:** Once properly aligned, fully tighten all Bracket to vehicle hardware only. If reinstalling fill panel and/or plastic splash guard then temporarily remove the Grille Guard. Otherwise, fully tighten all hardware at this time and proceed to the last step.
8. **To reinstall the plastic fill panel:**
 - a. Hold the fill panel up to the Support Brackets. Cut along the approximate area as indicated on the fill panel to clear the Support Brackets, **(Figure 14)**. **NOTE:** Only cut enough to clear the Brackets. DO not cut completely through the front edge of the fill panel.
 - b. Temporarily remove the Support Brackets. **WARNING!** To avoid possible injury or damage to vehicle, use stands or blocks to hold the Bumper up when removing the factory bolts. Reinstall the fill panel. Slide the Support Brackets through the fill panel cut outs, trim as required, and reinstall Support Brackets, see **Steps 4 & 5**.
 - c. Tighten fill panel hardware.
9. **To reinstall the plastic splash guard:**
 - a. Hold the plastic splash guard up in its original position against the Mounting Brackets. Mark the location of the Mounting Brackets onto the inside of the splash guard, **(Figure 15)**.
 - b. Cut out the sections to clear the Mounting Brackets. **IMPORTANT:** To maintain strength, remove as little material from the plastic splash guard as possible. Do not cut completely through the bottom edge of the splash guard.
 - c. Temporarily remove the Mounting Brackets. Reattach the top of the splash guard using the factory hardware, **(Figure 1)**. Slide the Mounting Brackets through the splash guard cut outs, trim as required, and reinstall both Mounting Brackets, see **Step 3**.
 - d. Next, locate the mounting location for the driver/left side Splash Guard Bracket, **(Figure 16)**. **NOTE:** Both Splash Guard Brackets look similar but each one is unique. Use **Figure 17** to help identify the correct Bracket. Reuse the metal plate factory bolt to attach the Bracket to the front of the frame, **(Figures 2 & 18)**. Leave hardware loose at this time.
 - e. Repeat the previous step for passenger/right side Splash Guard Bracket installation.
 - f. Align the Splash Guard Brackets with the bottom of the splash guard. Secure the bottom of the splash guard to the Brackets using the provided (2) 8mm Hex Bolts, (4) 8mm Flat Washers and (2) 8mm Nylon Lock Nuts, **(Figure 18)**. Tighten all splash guard hardware.
10. Repeat **Steps 6 & 7** to reinstall the Grille Guard and fully tighten all hardware.
11. Do periodic inspections of the installation to make sure that all hardware is secure and tight.

To protect your investment, wax this product after installing. Regular waxing is recommended to add a protective layer over the finish. Do not use any type of polish or wax that may contain abrasives that could damage the finish. Mild soap may be used to clean the Grille Guard.

Driver/left Side Installation Pictured

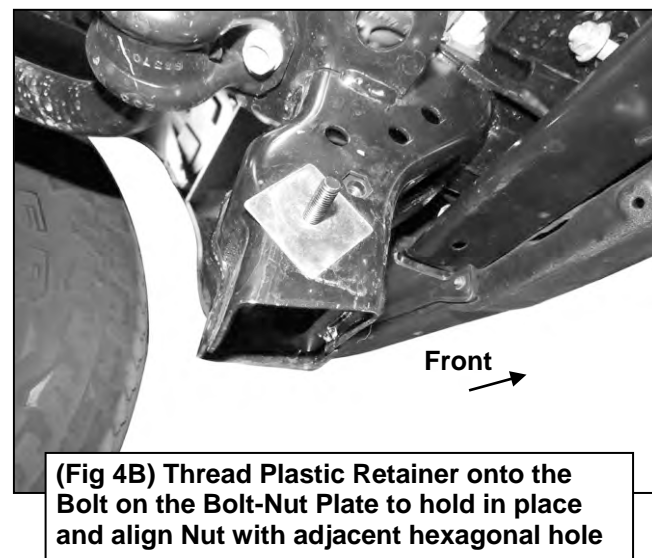
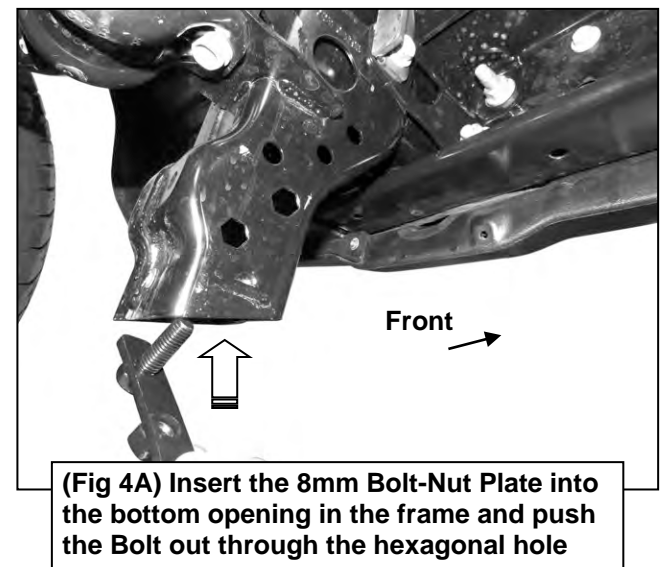
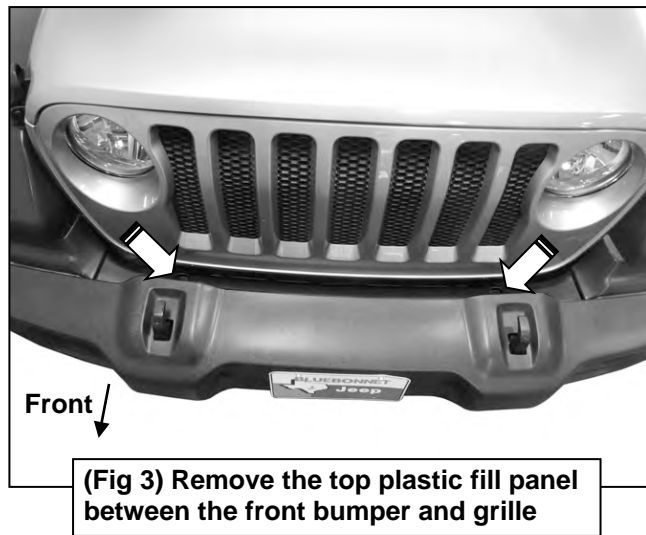
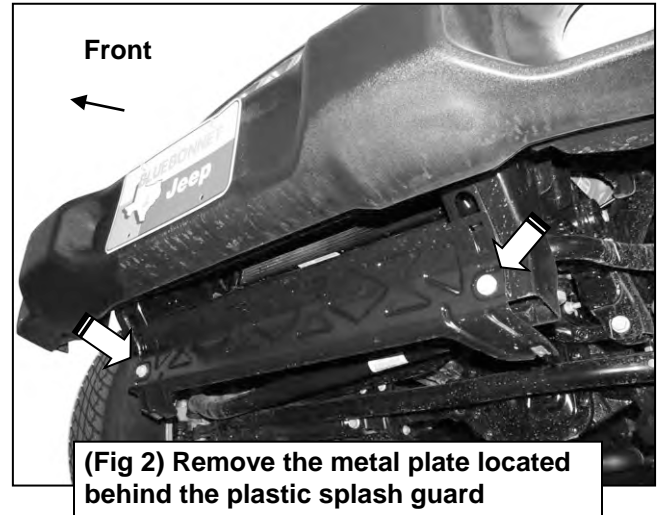
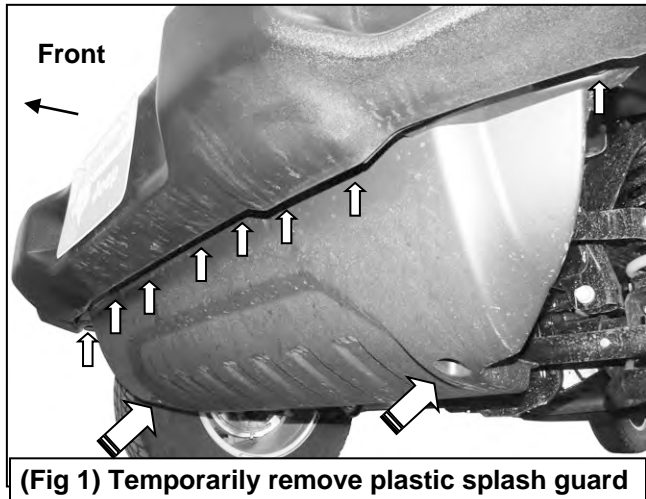

Driver/left Side Installation Pictured

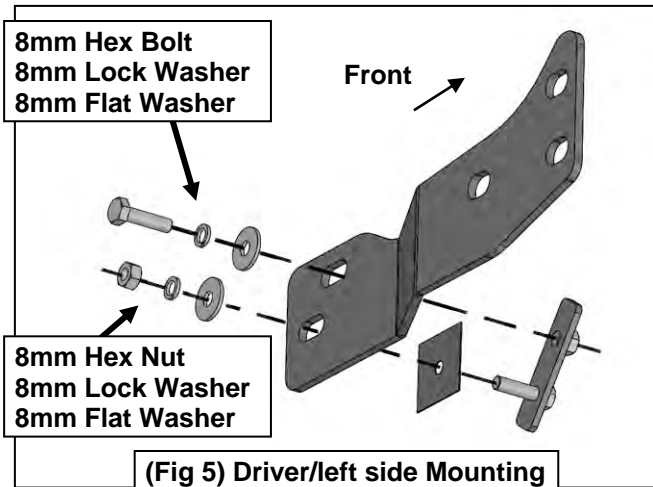

(Fig 5) Driver/left side Mounting Bracket with Bolt-Nut Plate

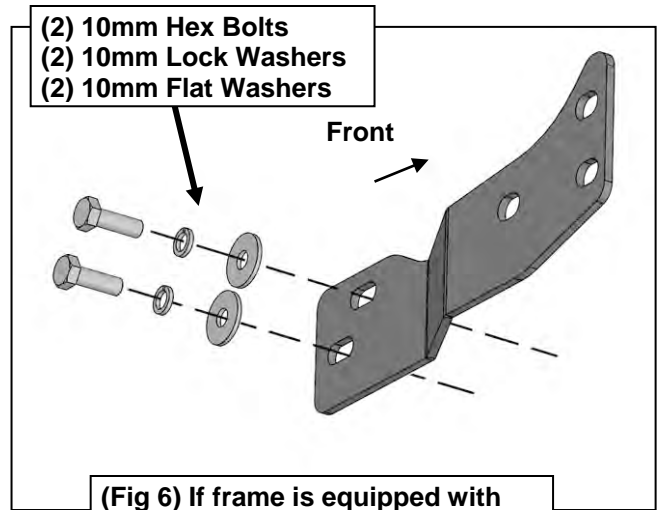

(Fig 6) If frame is equipped with threaded inserts use 10mm Bolts

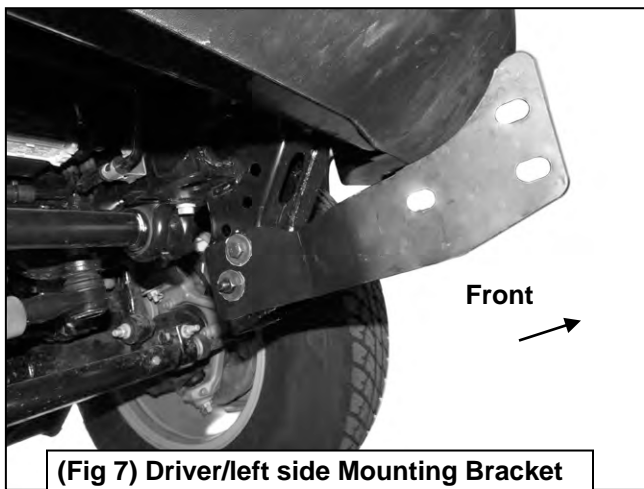

(Fig 7) Driver/left side Mounting Bracket attached to the inside of the frame

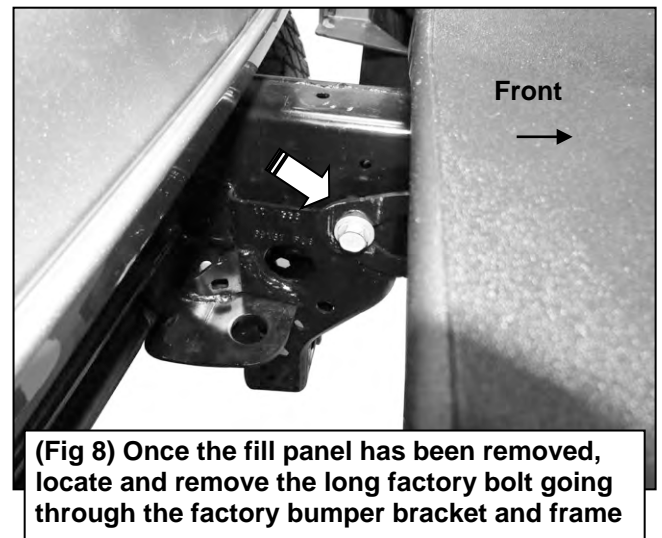

(Fig 8) Once the fill panel has been removed, locate and remove the long factory bolt going through the factory bumper bracket and frame

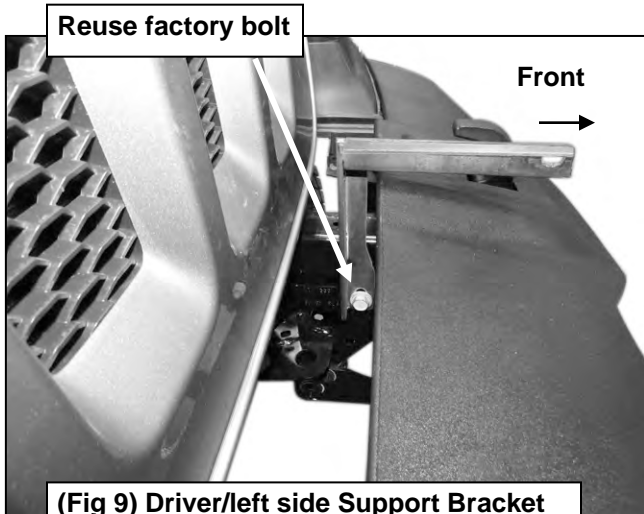

(Fig 9) Driver/left side Support Bracket attached to the inside of the frame

WARNING! DO NOT remove both factory bolts at once or bumper may fall. Install one side at a time to avoid possible injury or damage to vehicle.

Driver/left Side Installation Pictured

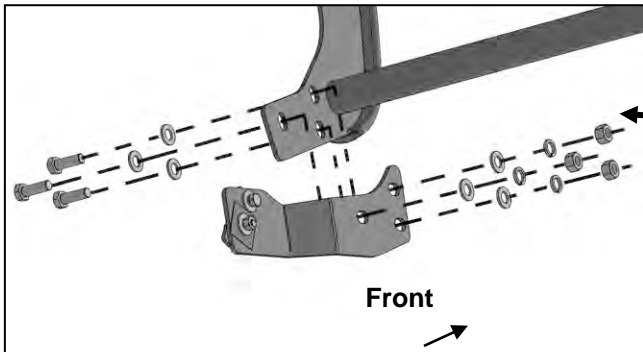

- (3) 12mm Hex Bolts
- (6) 12mm Flat Washers
- (3) 12mm Lock Washers
- (3) 12mm Hex Nuts

(Fig 10) Attach Grille Guard to the outside of the Driver/left side Mounting Bracket

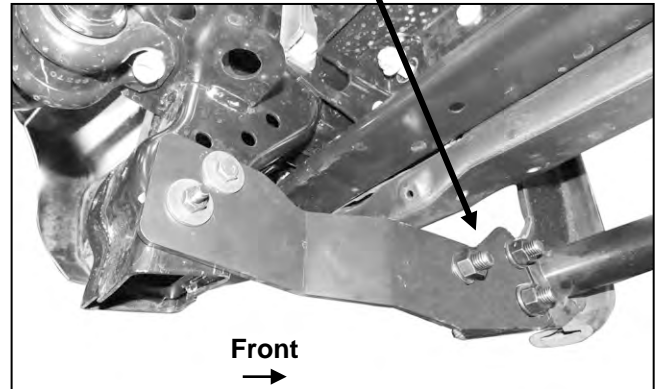

(Fig 11) Driver/left side Mounting Bracket attached to the inside of Grille Guard

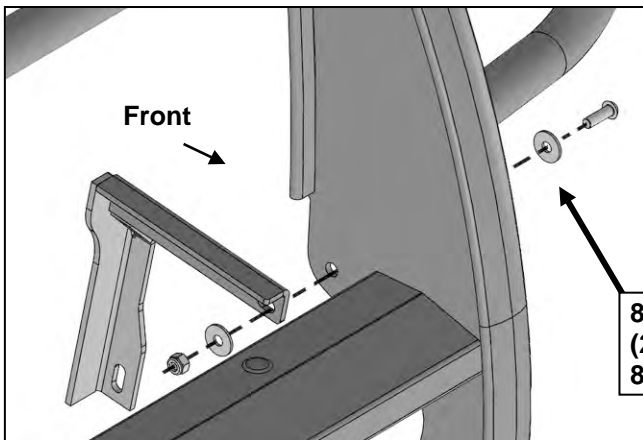

- 8mm Button Head Bolt
- (2) 8mm Flat Washers
- 8mm Nylon Lock Nut

(Fig 12) Attach Grille Guard to the outside of the Driver/left Support Bracket

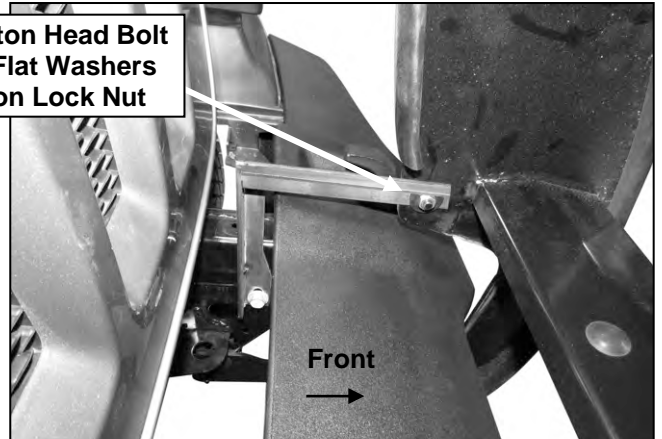

(Fig 13) Driver/left Support Bracket attached to the inside of the Grille Guard

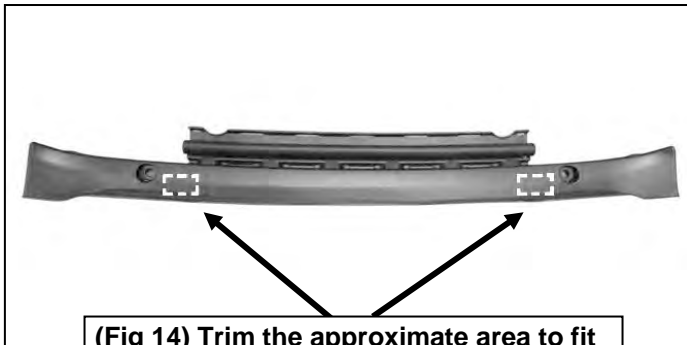

(Fig 14) Trim the approximate area to fit Support Brackets through fill panel

Driver/left Side Installation Pictured



(Fig 15) Trim the approximate area to clear the Mounting Brackets through the splash guard

Temporarily, remove Grille Guard only. Hold the splash guard up in position against the Mounting Brackets. Mark the cut area on the inside of the cover. Start with a small opening and slowly enlarge the opening to get the best fit around the brackets. Area cut from cover pictured for example only.

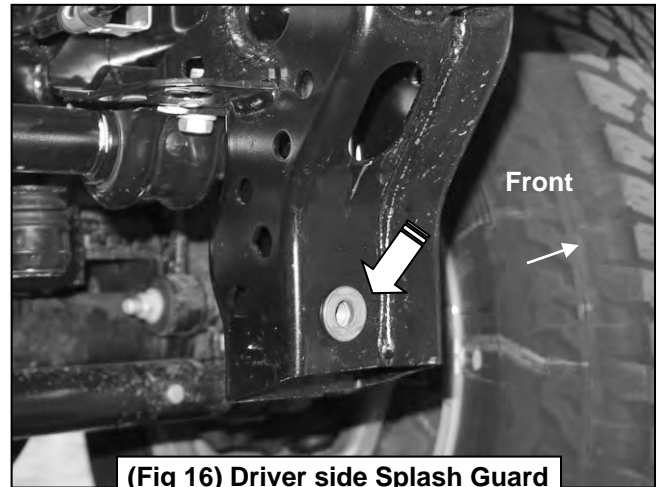

(Fig 16) Driver side Splash Guard Bracket mounting location

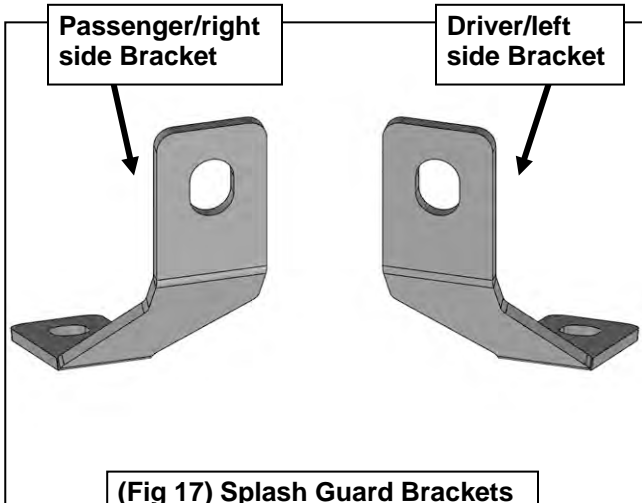

(Fig 17) Splash Guard Brackets

Reuse factory bolt from metal plate to attach the Bracket to the frame

8mm Hex Bolt
(2) 8mm Flat Washers
8mm Nylon Lock Nut

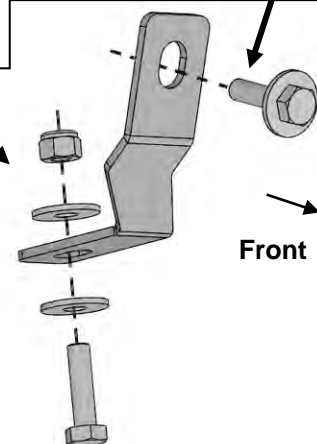

(Fig 18) Attach Driver/left side Splash Guard Bracket to frame and splash guard



Complete Installation