

7929 Lincoln Ave. Riverside, CA 92504  
Phone: 951.689.ICON | Fax: 951.689.1016

PART #	DESCRIPTION
21020	07-UP JEEP WRANGLER JK ADJUSTABLE FRONT TRACK BAR

COMPONENTS INCLUDED	
(1) 124043 JK FRONT ADJ TRACK BAR (1) 157520 L-R ADJ SLEEVE	(2) 217200 HEIM SPACER .565 X 1.625 (1) 295511 JM12T ROD END
HARDWARE INCLUDED	
(2) 605145 3/8-16 X 1.00 12 PT BOLT	
TOOLS REQUIRED	
TORQUE WRENCH 15MM SOCKET / WRENCH 21MM SOCKET / WRENCH	5/16" SOCKET / WRENCH 3/8" SOCKET WRENCH
TECH NOTES	
<p>1. IF USED WITH THE STOCK TRACK BAR BRACKET, TRIMMING IS REQUIRED.</p> <p>2. DO NOT EXCEED 2.00" ADJUSTMENT FROM THE CENTER OF THE ROD END TO THE EDGE OF THE TRACK BAR PINCH HOUSING. FAILURE CAUSED BY EXCESSIVE ADJUSTMENT WILL NOT BE COVERED UNDER ICON'S WARRANTY POLICY. REFER TO TECH NOTE PHOTO #2.</p>	



WARNING!
<p>** READ ALL INSTRUCTIONS THOROUGHLY FROM START TO FINISH BEFORE BEGINNING INSTALLATION! IF THESE INSTRUCTIONS ARE NOT PROPERLY FOLLOWED SEVERE FRAME, SUSPENSION AND TIRE DAMAGE MAY RESULT TO THE VEHICLE!</p> <p>** ICON VEHICLE DYNAMICS RECOMMENDS THAT YOU EXERCISE EXTREME CAUTION WHEN WORKING UNDER A VEHICLE THAT IS SUPPORTED WITH JACK STANDS.</p>

## INSTALLATION

1. Remove the stock track bar from the frame and axle using (2) 21mm. Vehicle may shift slightly.
2. Using factory hardware, install the front track bar using a 21mm [Torque to factory spec].
3. The front track bar features a left/right adjusting collar for on vehicle adjustment. The adjustable end goes towards the axle using the factory hardware. The bend should point forward and up allowing for differential clearance.
4. If installing in factory mount, the factory track bar bracket at the axle will need to be cleared for the pinch block. [FIGURE 1]

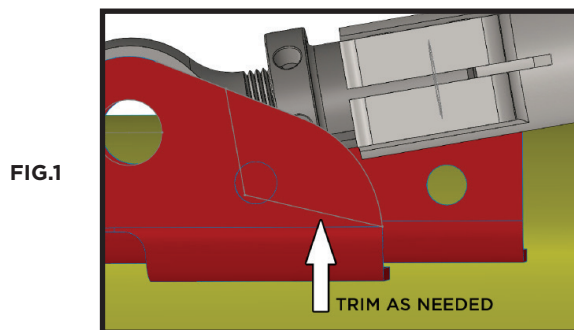

5. Paint exposed metal after trimming.
6. Once installed, the track bar can be adjusted to center the axle. Loosen the pinch bolts using a 3/8" 12pt. Turn collar to desired length. Line up the slit in the collar with the slit in the tube, apply blue thread locker to the pinch bolts and tighten in an opposing pattern. DO NOT OVERTIGHTEN! [Torque pinch bolts to 25 ft-lbs]
7. For final steering wheel alignment, loosen the adjusting collar in the drag link using a 15mm, and adjust as needed [Torque to factory spec]. FAILURE TO CENTER STEERING WHEEL BEFORE DRIVING WILL RESULT IN COMPUTER STABILITY CONTROL ISSUES.

**VERIFY ALL FASTENERS ARE PROPERLY TORQUED BEFORE DRIVING VEHICLE.**

**RETORQUE ALL NUTS, BOLTS AND LUGS AFTER 100 MILES AND PERIODICALLY THEREAFTER.**

[TECH NOTE #2]

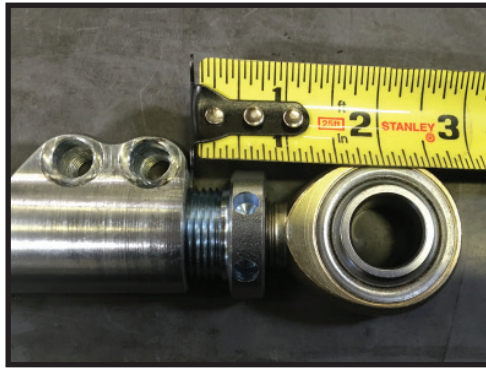

## ICON VEHICLE DYNAMICS LIMITED LIFETIME WARRANTY

ICON Vehicle Dynamics warrants to the original retail purchaser who owns the vehicle on which the product was originally installed. ICON Vehicle Dynamics does not warrant the product for finish, alterations, modifications and/or installation contrary to ICON Vehicle Dynamics instructions. ICON Vehicle Dynamics products are not designed, nor are they intended to be installed on vehicles used in race applications, for racing purposes or for similar activities. (A "race" is defined as any contest between two or more vehicles, or a contest of one or more vehicles against the clock, whether or not such contest is for a prize). This warranty does not include coverage for police or taxi vehicles, race vehicles, or vehicles used for government or commercial purposes. Also excluded from this warranty are sales outside of the United States of America and Canada.

ICON Vehicle Dynamics' obligation under this warranty is limited to the repair or replacement, at ICON Vehicle Dynamics' discretion, of the defective product. Any and all costs of removal, installation or re-installation, freight charges and incidental or consequential damages are expressly excluded from this warranty. Items that are subject to wear are not considered defective when worn and are not covered.

ICON Vehicle Dynamics components must be installed as a complete kit as shown in our current application guide. Any substitutions or exemptions of required components will immediately void the warranty. Some finish damage may happen to parts during shipping and is not covered under warranty.

This warranty is expressly in lieu of all other warranties expressed or implied. This warranty shall not apply to any product that has been improperly installed, modified or customized subject to accident, negligence, abuse or misuse.



**ICON VEHICLE DYNAMICS®**  
PERFORMANCE SUSPENSION SYSTEMS AND SHOCK ABSORBERS

7929 Lincoln Ave. Riverside, CA 92504 Phone: 951.689.ICON Fax: 951.689.1016  
[www.iconvehicledynamics.com](http://www.iconvehicledynamics.com)



**FOLLOW US ON FACEBOOK!**



7929 Lincoln Ave. Riverside, CA 92504  
Phone: 951.689.ICON | Fax: 951.689.1016

PART #	DESCRIPTION
21025	07-UP JEEP WRANGLER JK ADJUSTABLE REAR TRACK BAR

COMPONENTS INCLUDED	
(1) 124003 JK REAR ADJUSTABLE TRACK BAR (1) 157520 L-R ADJUSTER SLEEVE	(2) 217200 HEIM SPACER .565 X 1.625 (1) 295511 JM12T ROD END
HARDWARE INCLUDED	
(2) 605145 3/8-16 X 1.000 12 PT BOLT	
TOOLS REQUIRED	
TORQUE WRENCH CUTTING WHEEL (IF NECESSARY) BLACK SPRAY PAINT (IF NECESSARY)	21MM SOCKET / WRENCH 5/16" SOCKET / WRENCH 3/8" SOCKET WRENCH
TECH NOTES	
<p>1. IF USED WITH THE STOCK TRACK BAR BRACKET, TRIMMING IS REQUIRED.</p> <p>2. DO NOT EXCEED 2.000" ADJUSTMENT FROM THE CENTER OF THE ROD END TO THE EDGE OF THE TRACK BAR PINCH HOUSING. FAILURE CAUSED BY EXCESSIVE ADJUSTMENT WILL NOT BE COVERED UNDER ICON'S WARRANTY POLICY. REFER TO TECH NOTE PHOTO #2.</p>	



WARNING!
<p>** READ ALL INSTRUCTIONS THOROUGHLY FROM START TO FINISH BEFORE BEGINNING INSTALLATION! IF THESE INSTRUCTIONS ARE NOT PROPERLY FOLLOWED SEVERE FRAME, SUSPENSION AND TIRE DAMAGE MAY RESULT TO THE VEHICLE!</p> <p>** ICON VEHICLE DYNAMICS RECOMMENDS THAT YOU EXERCISE EXTREME CAUTION WHEN WORKING UNDER A VEHICLE THAT IS SUPPORTED WITH JACK STANDS.</p>

## INSTALLATION

1. Remove the stock track bar from the frame and axle using (2) 21mm. Vehicle may shift slightly.
2. Using factory hardware, install the rear track bar using a 21mm [Torque to factory spec].
3. If installing in factory mount, the track bar bracket will need to be clearanced. Some cutting is required. [FIGURE 1]
4. Paint exposed metal after trimming.

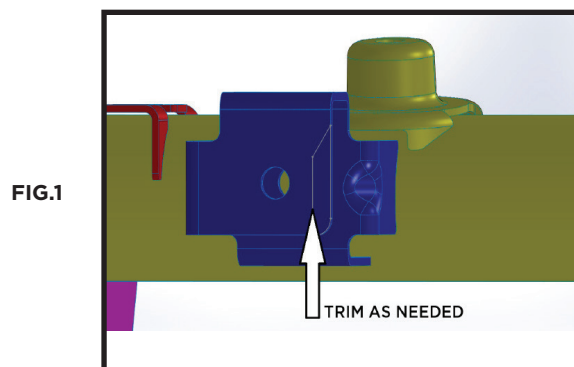

5. The rear track bar features a left/right adjusting collar for on vehicle adjustment. The adjustable end goes towards the axle using the factory hardware. The bend goes toward the rear, allowing for coil and differential clearance.
6. Once installed, the track bar can be adjusted to center the axle. Loosen the pinch bolts using a 3/8" 12pt. Turn collar to desired length. Line up the slit in the collar with the slit in the tube, apply blue thread locker to the pinch bolts and tighten in an opposing pattern. DO NOT OVERTIGHTEN! [Torque pinch bolts to 25 ft-lbs]

**VERIFY ALL FASTENERS ARE PROPERLY TORQUED BEFORE DRIVING VEHICLE.**

**RETORQUE ALL NUTS, BOLTS AND LUGS AFTER 100 MILES AND PERIODICALLY THEREAFTER.**

[TECH NOTE #2]

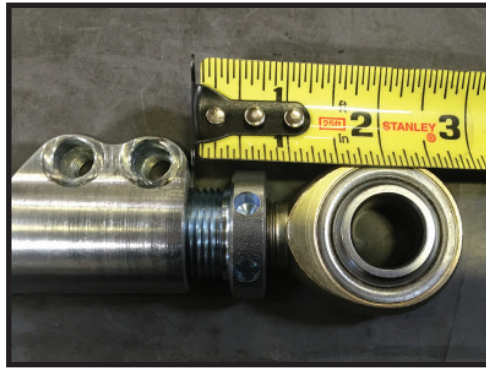

## ICON VEHICLE DYNAMICS LIMITED LIFETIME WARRANTY

ICON Vehicle Dynamics warrants to the original retail purchaser who owns the vehicle on which the product was originally installed. ICON Vehicle Dynamics does not warrant the product for finish, alterations, modifications and/or installation contrary to ICON Vehicle Dynamics instructions. ICON Vehicle Dynamics products are not designed, nor are they intended to be installed on vehicles used in race applications, for racing purposes or for similar activities. (A "race" is defined as any contest between two or more vehicles, or a contest of one or more vehicles against the clock, whether or not such contest is for a prize). This warranty does not include coverage for police or taxi vehicles, race vehicles, or vehicles used for government or commercial purposes. Also excluded from this warranty are sales outside of the United States of America and Canada.

ICON Vehicle Dynamics' obligation under this warranty is limited to the repair or replacement, at ICON Vehicle Dynamics' discretion, of the defective product. Any and all costs of removal, installation or re-installation, freight charges and incidental or consequential damages are expressly excluded from this warranty. Items that are subject to wear are not considered defective when worn and are not covered.

ICON Vehicle Dynamics components must be installed as a complete kit as shown in our current application guide. Any substitutions or exemptions of required components will immediately void the warranty. Some finish damage may happen to parts during shipping and is not covered under warranty.

This warranty is expressly in lieu of all other warranties expressed or implied. This warranty shall not apply to any product that has been improperly installed, modified or customized subject to accident, negligence, abuse or misuse.



**ICON VEHICLE DYNAMICS®**  
PERFORMANCE SUSPENSION SYSTEMS AND SHOCK ABSORBERS

7929 Lincoln Ave. Riverside, CA 92504 Phone: 951.689.ICON Fax: 951.689.1016  
[www.iconvehicledynamics.com](http://www.iconvehicledynamics.com)



**FOLLOW US ON FACEBOOK!**





7929 Lincoln Ave. Riverside, CA 92504  
Phone: 951.689.ICON | Fax: 951.689.1016

PART #	DESCRIPTION
21031	07-UP JEEP WRANGLER JK FRONT LOWER LINK KIT

COMPONENTS INCLUDED	
(2) 124039 JK FRONT LOWER FIXED LINK	
HARDWARE INCLUDED	
N/A	
TOOLS REQUIRED	
TORQUE WRENCH	21MM SOCKET / WRENCH
TECH NOTES	
N/A	



## INSTALLATION

1. Remove stock front lower link from driver side of vehicle using (2) 21mm.
2. Install the new front lower link using a 21mm [Torque to factory spec]. The bend in the link goes inboard for added tire clearance. The bend should be closer to the axle than the frame [FIGURE 1].

**WARNING!**

**\*\* READ ALL INSTRUCTIONS THOROUGHLY FROM START TO FINISH BEFORE BEGINNING INSTALLATION! IF THESE INSTRUCTIONS ARE NOT PROPERLY FOLLOWED SEVERE FRAME, SUSPENSION AND TIRE DAMAGE MAY RESULT TO THE VEHICLE!**

**\*\* ICON VEHICLE DYNAMICS RECOMMENDS THAT YOU EXERCISE EXTREME CAUTION WHEN WORKING UNDER A VEHICLE THAT IS SUPPORTED WITH JACK STANDS.**

FIG.1

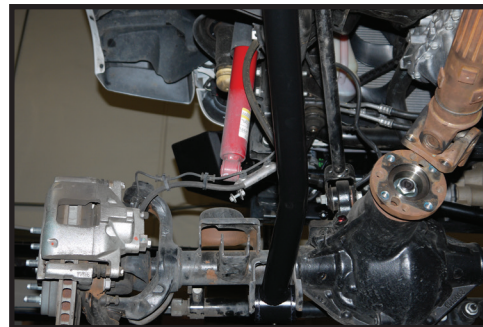

3. Repeat steps for passenger side.

**VERIFY ALL FASTENERS ARE PROPERLY TORQUED BEFORE DRIVING VEHICLE.**  
**RETORQUE ALL NUTS, BOLTS AND LUGS AFTER 100 MILES AND PERIODICALLY THEREAFTER.**

## ICON VEHICLE DYNAMICS LIMITED LIFETIME WARRANTY

ICON Vehicle Dynamics warrants to the original retail purchaser who owns the vehicle on which the product was originally installed. ICON Vehicle Dynamics does not warrant the product for finish, alterations, modifications and/or installation contrary to ICON Vehicle Dynamics instructions. ICON Vehicle Dynamics products are not designed, nor are they intended to be installed on vehicles used in race applications, for racing purposes or for similar activities. (A "race" is defined as any contest between two or more vehicles, or a contest of one or more vehicles against the clock, whether or not such contest is for a prize). This warranty does not include coverage for police or taxi vehicles, race vehicles, or vehicles used for government or commercial purposes. Also excluded from this warranty are sales outside of the United States of America and Canada.

ICON Vehicle Dynamics' obligation under this warranty is limited to the repair or replacement, at ICON Vehicle Dynamics' discretion, of the defective product. Any and all costs of removal, installation or re-installation, freight charges and incidental or consequential damages are expressly excluded from this warranty. Items that are subject to wear are not considered defective when worn and are not covered.

ICON Vehicle Dynamics components must be installed as a complete kit as shown in our current application guide. Any substitutions or exemptions of required components will immediately void the warranty. Some finish damage may happen to parts during shipping and is not covered under warranty.

This warranty is expressly in lieu of all other warranties expressed or implied. This warranty shall not apply to any product that has been improperly installed, modified or customized subject to accident, negligence, abuse or misuse.



**ICON VEHICLE DYNAMICS®**  
PERFORMANCE SUSPENSION SYSTEMS AND SHOCK ABSORBERS

7929 Lincoln Ave. Riverside, CA 92504 Phone: 951.689.ICON Fax: 951.689.1016  
[www.iconvehicledynamics.com](http://www.iconvehicledynamics.com)



**FOLLOW US ON FACEBOOK!**



7929 Lincoln Ave. Riverside, CA 92504  
Phone: 951.689.ICON | Fax: 951.689.1016

PART #	DESCRIPTION
22040	07-UP JEEP WRANGLER JK 3" BOX KIT

COMPONENTS INCLUDED	
(2) 124023 JK FRONT SWAY BAR LINK 3" (2) 127200 JK FRONT BUMP STOP SPACER 1" (2) 127201 JK REAR BUMP STOP SPACER 1"	(4) 139001 SLEEVE .625 X .508 X 1.625 (1) 22040H 07-UP JK 3" BOX HARDWARE KIT (8) 297024 SWAY BAR URETHANE BUSHING
HARDWARE INCLUDED	
(2) 120038 JK REAR BRAKELINE DROP (4) 605016 5/16 SAE FLAT WASHER (2) 605052 1/4-20 NYLOCK NUT (4) 605053 1/4 SAE FLAT WASHER (2) 605054 1/4-20 X .750 BOLT (4) 605075 5/16-18 X 1.500 CSUNK ALLEN BOLT (4) 605076 5/16-18 C-LOCK	(2) 605116 3/8-16 X 1.750 CSUNK ALLEN BOLT (2) 605122 3/8-16 C-LOCK NUT (2) 605133 3/8 SAE FLAT WASHER (2) 605308 1/2-13 X 3.000 BOLT (2) 605322 1/2-13 C-LOCK NUT (4) 605330 1/2 SAE FLAT WASHER (1) 605968 VIBRATITE BLUE
TOOLS REQUIRED	
HYDRAULIC JACK & JACK STANDS POWER DRILL 3/8" DRILL BIT ASSEMBLY / CHASSIS GREASE 7/32" & 3/16" ALLEN WRENCH	10MM SOCKET / WRENCH 15MM SOCKET / WRENCH 16MM SOCKET / WRENCH 18MM SOCKET / WRENCH 21MM SOCKET / WRENCH
TECH NOTES	
1. USING THE STOCK SHOCKS WITHOUT AN ICON SHOCK EXTENSION KIT WILL HINDER PERFORMANCE OF THIS KIT. FOR BEST RIDE QUALITY IT IS RECOMMEND TO USE ONE OF THE MANY SHOCK OPTIONS ICON OFFERS THAT ARE TUNED SPECIFIC TO THIS KIT.	
2. ICON 3" FRONT COIL SPRINGS (PART #22010) AND 2" REAR COIL SPRINGS (PART #22015) ARE REQUIRED FOR COMPLETE INSTALLATION OF THIS KIT.	

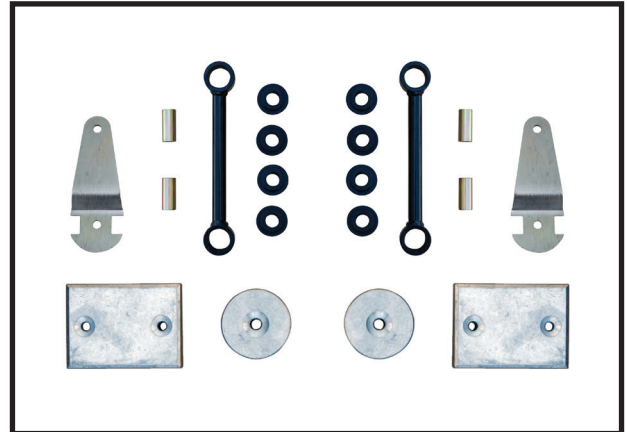

WARNING!
<b>** READ ALL INSTRUCTIONS THOROUGHLY FROM START TO FINISH BEFORE BEGINNING INSTALLATION! IF THESE INSTRUCTIONS ARE NOT PROPERLY FOLLOWED, SEVERE FRAME, SUSPENSION AND TIRE DAMAGE MAY RESULT TO THE VEHICLE!</b>
<b>** ICON VEHICLE DYNAMICS RECOMMENDS THAT YOU EXERCISE EXTREME CAUTION WHEN WORKING UNDER A VEHICLE THAT IS SUPPORTED WITH JACK STANDS.</b>

## INSTALLATION

- Using a properly rated jack, raise the front of the vehicle and support the frame rails with jack stands. Ensure the jack stands are secure and set properly before lowering the jack. NEVER WORK UNDER AN UNSUPPORTED VEHICLE.
- Dismount the front wheels from the vehicle.
- Using an 18 and 19mm remove the front sway bar links completely, they will not be reused. [FIGURE 1]

FIG.1



FIG.2



- For 2012+ models: Carefully remove the ABS connector and brake line bracket from the coil seat using a 10mm. [FIGURE 2]
- For 2007-2012 models: Remove the brake line bracket from the frame using a 10mm.
- For Rubicon models: Disconnect the locker control wires from the differential to allow the axle to droop.

- Using a 15mm disconnect the front drive shaft from the front differential. This will allow the axle to go low enough for coil removal later. [FIGURE 3]

FIG.3

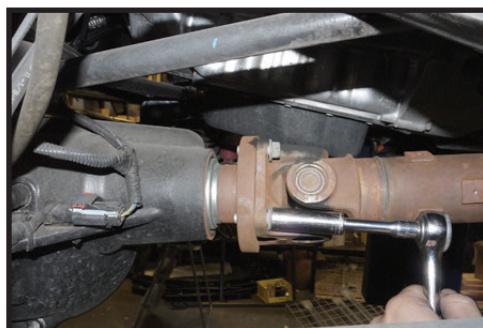

**5.** Using a 21mm disconnect the front track bar from the frame side [FIGURE 4]. Leave axle side connected unless you are installing an ICON Vehicle Dynamics Adjustable Track Bar (Part# 21020). Refer to #21020 instructions if replacing stock track bar.

FIG.4



**6.** With the front axle supported, remove the front shocks by loosening the upper stem and lower eyelet. The shock may spin when you try and remove the stem hardware - you will need to hold onto the shock body if this happens. The shocks are limiting droop so **MAKE SURE THE AXLE IS SUPPORTED OR THE AXLE WILL FALL** when the shocks are removed.

**7.** Lower the axle to unload the springs from the coil buckets and carefully remove the stock springs. [FIGURE 5]

FIG.5

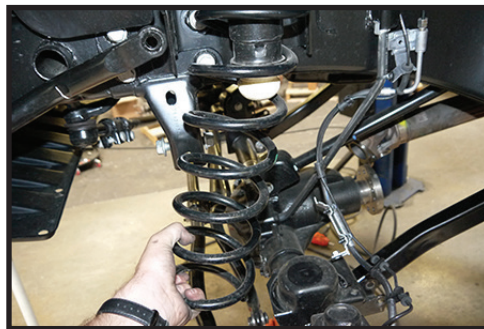

**8.** Drill a 3/8" hole in the center of the lower bump stop pad using the supplied bump stop spacer as a guide. [FIGURE 6]. With a 7/32" allen wrench install the supplied 3/8" allen bolt, washer, and lock nut to attach the bumpstop spacer to the spring pads [Torque to 35 ft-lbs]. [FIGURE 7]

FIG.6



FIG.7



**9.** Install the rubber spring isolator on top of the new coil spring, install the new coil spring on the axle and into the frame. You may need to lower the axle to allow access for the new coils, watch for wiring and hoses that may be stretched. Make sure the bottom of the coil spring is seated properly into the factory mount. Repeat on passenger side.

**10.** Slowly raise the axle making sure the coils align in the upper and lower seats and just far enough to install the shocks. See the instructions supplied with the shocks for installation of any of ICON's several shock options or shock extension option. If retaining the factory shocks and not adding shock extensions, the ride will be hindered greatly.

**11.** Assemble the supplied sway bar links by greasing the bushings and inserting them into the link. Grease the inside of the bushings and install the supplied sleeve. The factory hardware will be re-used where the sway bar connects to the ICON link, reinstall with blue loctite. The supplied 1/2 x 3" bolt, washer, and nut will be used to connect the link to the axle tab [Torque 1/2" hardware to 60 ft-lbs & factory hardware to factory specs]. [FIGURE 8]

FIG.8



FIG.9



12. Slightly bend the factory steel brake line roughly 30 degrees to allow for the additional droop travel. [FIGURE 9]
13. Reinstall the factory frame bolt thru the brake line bracket using a 10mm. For 2012+ models install the bracket on the lower coil seat using a 10mm [Torque to factory specs].
14. Install track bar bolt using supplied blue thread locker [Torque to factory specs].
15. Install wheels and lower to ground.
16. Reinstall the front driveshaft flange to the front differential [Torque to factory specs].

## REAR

1. Using a properly rated jack, raise the rear of the vehicle and support the frame rails with jack stands. Ensure the jack stands are secure and set properly before lowering the jack. NEVER WORK UNDER AN UNSUPPORTED VEHICLE.
2. Dismount the rear wheels from the vehicle.
3. With the rear axle supported with a floor jack, use a 16 and 18mm to remove the rear shocks by loosening the upper barpin and lower eyelet. The shocks are limiting droop so MAKE SURE THE AXLE IS SUPPORTED OR THE AXLE WILL FALL when the shocks are removed.
4. Using a 10mm remove brake line bracket bolt from frame on driver and passenger side.
5. Using a 21mm remove frame side track bar bolt.
6. Using an 18mm remove the lower sway bar link bolt from driver and passenger side.
7. Unhook the brake cable from the hook above the driveshaft
8. Lower the axle to unload the springs from any pressure and carefully remove the stock springs.
9. Using the 3/16" allen wrench, install bumpstop spacers with the 5/16" allen head bolts, washers, and nuts [Torque to 24 ft-lbs]. [FIGURE 10]

FIG.10

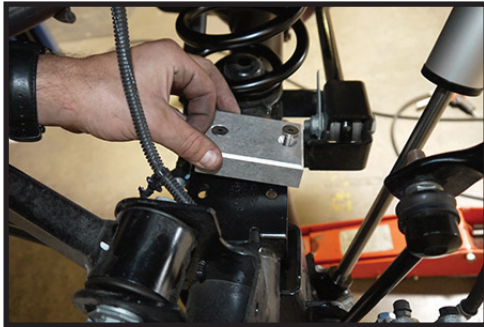

FIG.11



10. Making sure the factory rubber spring isolator is located in the upper coil spring mount on the frame, install the new coil springs on the axle and into the frame. You may need to lower the axle to allow access for the new coils, watch for wiring and hoses that may be stretched. Make sure the bottom of the coil spring is seated properly into the factory mount. [FIGURE 11]

11. Slowly raise the axle making sure the coils align in the upper and lower seats and just far enough to install the shocks. See the instructions supplied with the shocks for installation of any of ICON's several shock options or shock extension option. If retaining the factory shocks and not adding shock extensions, the ride will be hindered greatly.

12. Install the track bar bolt at frame and flip the bolt so it points to the rear of the vehicle or it will interfere with the bump stop spacer at full bottom causing damage.

13. Reconnect factory sway bar links using blue thread locker [Torque to factory specs]. [FIGURE 12]

FIG.12

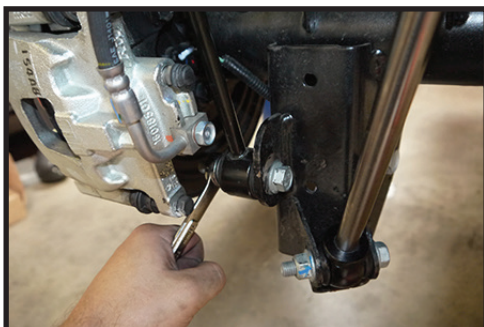

FIG.13



14. Attach the supplied brake line drops with the supplied 1/4" hardware [Torque to 12 ft-lbs]. [FIGURE 13]

15. Rehook the brake line cable above the driveshaft.

**16.** Carefully reinstall wheels onto vehicle and lower vehicle to the ground.

**17.** Reconnect all brake line brackets and routing clips. When re-installing these lines and clips make sure the lines will not interfere with any of the suspension components.

**VERIFY ALL FASTENERS ARE PROPERLY TORQUED BEFORE DRIVING VEHICLE.**

**RETORQUE ALL NUTS, BOLTS AND LUGS AFTER 100 MILES AND PERIODICALLY THEREAFTER.**

## **ICON VEHICLE DYNAMICS LIMITED LIFETIME WARRANTY**

ICON Vehicle Dynamics warrants to the original retail purchaser who owns the vehicle on which the product was originally installed. ICON Vehicle Dynamics does not warrant the product for finish, alterations, modifications and/or installation contrary to ICON Vehicle Dynamics instructions. ICON Vehicle Dynamics products are not designed, nor are they intended to be installed on vehicles used in race applications, for racing purposes or for similar activities. (A "race" is defined as any contest between two or more vehicles, or a contest of one or more vehicles against the clock, whether or not such contest is for a prize). This warranty does not include coverage for police or taxi vehicles, race vehicles, or vehicles used for government or commercial purposes. Also excluded from this warranty are sales outside of the United States of America and Canada.

ICON Vehicle Dynamics' obligation under this warranty is limited to the repair or replacement, at ICON Vehicle Dynamics' discretion, of the defective product. Any and all costs of removal, installation or re-installation, freight charges and incidental or consequential damages are expressly excluded from this warranty. Items that are subject to wear are not considered defective when worn and are not covered.

ICON Vehicle Dynamics components must be installed as a complete kit as shown in our current application guide. Any substitutions or exemptions of required components will immediately void the warranty. Some finish damage may happen to parts during shipping and is not covered under warranty.

This warranty is expressly in lieu of all other warranties expressed or implied. This warranty shall not apply to any product that has been improperly installed, modified or customized subject to accident, negligence, abuse or misuse.



**ICON VEHICLE DYNAMICS®**  
PERFORMANCE SUSPENSION SYSTEMS AND SHOCK ABSORBERS

7929 Lincoln Ave. Riverside, CA 92504 Phone: 951.689.ICON Fax: 951.689.1016  
[www.iconvehicledynamics.com](http://www.iconvehicledynamics.com)



**FOLLOW US ON FACEBOOK!**



7929 Lincoln Ave. Riverside, CA 92504  
 Phone: 951.689.ICON | Fax: 951.689.1016

PART #	DESCRIPTION
27725CP	07-18 JK 3" REAR 2.5 PB CDCV SHOCK

COMPONENTS INCLUDED	
(2) 124949C 07-UP JK 3" REAR 2.5 VS PB CDCV (2) 120020 JK REAR SHOCK STEM ADAPTER	(2) 611007 MEDIUM DUTY STEM BUSHING KIT
HARDWARE INCLUDED	
611007 HARDWARE KIT	
(2) 9/16" ID STEM BUSHING (1) 12MM ID STEM WASHER	(1) 9/16" ID STEM WASHER (1) M12-1.25 NYLOCK NUT
TOOLS REQUIRED	
JACK JACK STANDS TORQUE WRENCH	17MM SOCKET / WRENCH 18MM SOCKET / WRENCH 19MM SOCKET / WRENCH
TECH NOTES	
<p>1. YOUR ICON SHOCK ASSEMBLIES COME FACTORY CHARGED TO 150 PSI. RELEASING NITROGEN PRESSURE MAY LEAD TO SHOCK MALFUNCTION AND REDUCED RIDE QUALITY. FAILURE CAUSED BY LOW NITROGEN PRESSURE IS NOT COVERED UNDER ICON'S WARRANTY POLICY.</p> <p>2. THESE SHOCKS REQUIRE A MINIMUM BUMP STOP SPACER OF 1.00" WHICH IS SUPPLIED IN ICON'S 3" SUSPENSION SYSTEM.</p>	



**WARNING!**

**\*\* READ ALL INSTRUCTIONS THOROUGHLY FROM START TO FINISH BEFORE BEGINNING INSTALLATION! IF THESE INSTRUCTIONS ARE NOT PROPERLY FOLLOWED SEVERE FRAME, SUSPENSION AND TIRE DAMAGE MAY RESULT TO THE VEHICLE!**

**\*\* ICON VEHICLE DYNAMICS RECOMMENDS THAT YOU EXERCISE EXTREME CAUTION WHEN WORKING UNDER A VEHICLE THAT IS SUPPORTED WITH JACK STANDS.**

**\*\* ICON VEHICLE DYNAMICS RECOMMENDS ALL INSTALLATION TO BE PERFORMED BY A PROFESSIONAL SHOP/SERVICE TECHNICIAN. PRODUCT FAILURE CAUSED BY IMPROPER INSTALLATION WILL NOT BE COVERED UNDER ICON'S WARRANTY POLICY.**

## INSTALLATION

- Using a properly rated jack, raise the rear of the vehicle and support the frame rails with jack stands. Ensure the jack stands are secure and set properly before lowering the jack. NEVER WORK UNDER AN UNSUPPORTED VEHICLE. Remove the rear wheels.
- Use a floor jack to support the rear axle, slightly raising it to take the tension off of the shocks. Using an 18MM, remove the driver side lower shock bolt.
- Use a 17MM to loosen the upper shock mount bolts and remove the OEM shock. Keep all hardware to be reused.
- Install stem hardware as seen in diagram. Install the lock nut until lock is engaged. Do not overtighten bushing assembly as this can lead to premature bushing wear. Failure caused by incorrect installation of bushings is not covered under ICON's warranty policy.

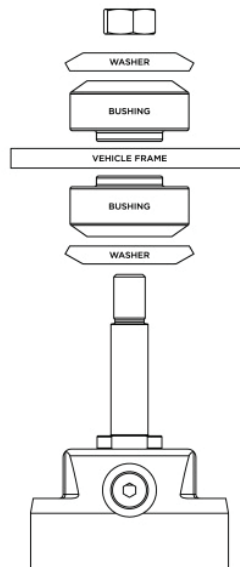

**5.** Install upper adapter plate into OEM shock mount using OEM hardware. [Torque to factory spec] Reservoir should be oriented away from the axle housing to avoid damage. Check clearance between shock and rear sway bar. Rotate shock as needed to avoid any contact. [FIGURE 1]

**FIG.1**



**6.** With the spacers in the rod end, install lower shock mount into factory mount. Insert OEM bolt into the factory shock mount. [Torque to factory spec.] Lifting or lowering of the axle housing may be necessary to align the spacers with the holes in the factory mount.

**7.** Repeat steps 3-6 for passenger side.

**8.** Reinstall wheels and carefully lower the vehicle to the ground. [Torque lugs to factory spec]

***VERIFY ALL FASTENERS ARE PROPERLY TORQUED BEFORE DRIVING VEHICLE.***

***RETORQUE ALL NUTS, BOLTS AND LUGS AFTER 100 MILES AND PERIODICALLY THEREAFTER.***

## 2.5 VS SERIES SHOCK & COILOVER TECHNICAL INFORMATION

### MAINTENANCE

ICON shock absorbers are a high quality rebuildable race style shock absorber designed for optimal performance. With a unit of this caliber on your vehicle, routine maintenance is required to keep them looking and operating in like new condition. Residual oil and assembly lube may be present at all seal paths from the factory out of the box and is considered normal. Pooling of oil however is not acceptable at any time and one should contact the ICON dealer where purchased.

**BELOW ARE GUIDELINES BASED ON HOW YOU USE YOUR VEHICLE BUT YOUR MILEAGE MAY VARY:**

#### **STREET USE:**

- Send in for factory servicing every 40,000 miles or if a leak develops, ride quality decreases, or they begin to make excessive noise.
- Remove any buildup of road salt, mud, or debris from shocks and coil springs anytime accrued
- Clean with mild soap and water with each oil change or anytime you notice build up.
- Wax the cylinders yearly with automotive wax to prevent corrosion.
- Check nitrogen pressure yearly. (252004 charge needle assembly available at any ICON distributor)
- Check bearings for excessive wear yearly.
- **DO NOT** apply any type of lube to the upper and lower bearings.

#### **STREET/DIRT:**

- Send in for factory servicing every 15,000 miles or if a leak develops, ride quality decreases, or they begin to make excessive noise.
- Clean with mild soap and water with each oil change, offroad trip, or anytime you notice build up.
- Wax the cylinders yearly with automotive wax to prevent corrosion.
- Check nitrogen pressure each dirt outing. (252004 charge needle assembly available at any ICON distributor)
- Check bearings for excessive wear yearly.
- **DO NOT** apply any type of lube to the upper and lower bearings.

#### **DIRT USE:**

- Send in for factory servicing every 1,000 miles.
- Check nitrogen pressure each outing. (252004 charge needle assembly available at any ICON distributor)
- Remove any buildup of mud or debris from shocks and coil springs after every outing.

#### **SELF-SERVICE:**

- Contact ICON for service kits & tools at (951) 689-4266.

### PRODUCT REGISTRATION

Please visit: <http://www.iconvehicledynamics.com/tech-support/registration/> to register your product.

### ICON VEHICLE DYNAMICS SHOCK ABSORBER WARRANTY

This shock absorber has a 1 year warranty against any manufacturer's defects. If a shock fails within the initial year of ownership, the shock must be shipped to ICON Vehicle Dynamics for inspection and service. If a shock is inspected and it has been determined the shock failed due to neglect, damage caused by improper installation or any other reason besides "normal wear and tear", the owner of said shock is responsible for all service costs. This includes labor, parts, and shipping.

ICON Vehicle Dynamics warrants to the original retail purchaser who owns the vehicle on which the product was originally installed. ICON Vehicle Dynamics does not warrant the product for finish, alterations, modifications and/or installation contrary to ICON Vehicle Dynamics instructions. ICON Vehicle Dynamics products are not designed, nor are they intended to be installed on vehicles used in race applications, for racing purposes or for similar activities. (A "race" is defined as any contest between two or more vehicles, or a contest of one or more vehicles against the clock, whether or not such contest is for a prize). This warranty does not include coverage for police or taxi vehicles, race vehicles, or vehicles used for government or commercial purposes. Also excluded from this warranty are sales outside of the United States of America and Canada.

ICON Vehicle Dynamics' obligation under this warranty is limited to the repair or replacement, at ICON Vehicle Dynamics' discretion, of the defective product. Any and all costs of removal, installation or re-installation, freight charges and incidental or consequential damages are expressly excluded from this warranty. Items that are subject to wear are not considered defective when worn and are not covered.

ICON Vehicle Dynamics components must be installed as a complete kit as shown in our current application guide. Any substitutions or exemptions of required components will immediately void the warranty. Some finish damage may happen to parts during shipping and is not covered under warranty.

This warranty is expressly in lieu of all other warranties expressed or implied. This warranty shall not apply to any product that has been improperly installed, modified or customized subject to accident, negligence, abuse or misuse.

To send a shock in for warranty please visit our website <http://www.iconvehicledynamics.com/tech-support/shock-service/>



**ICON VEHICLE DYNAMICS®**  
PERFORMANCE SUSPENSION SYSTEMS AND SHOCK ABSORBERS

7929 Lincoln Ave. Riverside, CA 92504 Phone: 951.689.ICON Fax: 951.689.1016  
[www.iconvehicledynamics.com](http://www.iconvehicledynamics.com)



**FOLLOW US ON FACEBOOK!**



7929 Lincoln Ave. Riverside, CA 92504  
Phone: 951.689.ICON | Fax: 951.689.1016

PART #	DESCRIPTION
27820CP	07-18 JK 3" FRONT 2.5 RR CDCV SHOCK

COMPONENTS INCLUDED	
(2) 124947C JK 3" FRONT 2.5 RR CDCV SHOCK (2) 611007 9/16" MEDIUM DUTY STEM BUSHING	(2) 611057 JK 2.5 FRONT LOWER BRACKET (2) 611058 JK FRONT RESI MOUNT KIT 2.0/2.5
HARDWARE INCLUDED	
(4) 257164 HEIM SPACER COM10	
611007 HARDWARE KIT	
(2) MED DUTY 9/16 ID STEM BUSHING (1) MED DUTY 9/16 ID STEM WASHER	(1) MED DUTY 12MM ID STEM WASHER (1) M12-1.25 NYLOCK NUT
611057 HARDWARE KIT	
(1) 124021 JK 2.5" LOWER SHOCK DOUBLER (1) 139004 .750 X .510 X 1.450 SLEEVE (1) 159007 .750 X .510 X 1.530 WELD SPACER (1) 605101 3/8 X 1 BOLT (1) 605121 3/8 LOCK NUT	(2) 605133 3/8 FLAT WASHER (1) 605312 1/2 X 4.5 BOLT (1) 605321 1/2 LOCK NUT (2) 605330 1/2 FLAT WASHER
611058 HARDWARE KIT	
(1) 124016 JK FRONT 7.5" RESI MOUNT (2) 605144 3/8 X 3/4 FLANGED SELF TAP BOLT	(2) 605931 1/2 X 2 1/16 - 3 HOSE CLAMP
TOOLS REQUIRED	
JACK JACK STANDS WELDER BLACK SPRAY PAINT DRILL 21/64" DRILL BIT CENTER PUNCH	TORQUE WRENCH 8MM NUT DRIVER 9/16" SOCKET / WRENCH 17MM SOCKET / WRENCH 18MM SOCKET / WRENCH 19MM SOCKET / WRENCH
TECH NOTES	
1. YOUR ICON SHOCK ASSEMBLIES COME FACTORY CHARGED TO 150 PSI. RELEASING NITROGEN PRESSURE MAY LEAD TO SHOCK MALFUNCTION AND REDUCED RIDE QUALITY. FAILURE CAUSED BY LOW NITROGEN PRESSURE IS NOT COVERED UNDER ICON'S WARRANTY POLICY.	
2. REQUIRES 1" BUMP STOP SPACER (SUPPLIED WITH ICON 3" LIFT KIT).	
3. REQUIRES WELDING OF LOWER SHOCK TAB.	
4. FAILURE TO MOUNT SHOCK USING SUPPLIED TABS AND INSTRUCTIONS WILL RESULT IN SHOCK DAMAGE, VEHICLE DAMAGE, AND POSSIBLE INJURY.	
5. ORIENT HOSE CLAMP ON PASSENGER SIDE RESERVOIR SO THAT IT DOESN'T INTERFERE WITH THE WINDSHIELD WASHER RESERVOIR.	



WARNING!
<p><b>** READ ALL INSTRUCTIONS THOROUGHLY FROM START TO FINISH BEFORE BEGINNING INSTALLATION! IF THESE INSTRUCTIONS ARE NOT PROPERLY FOLLOWED SEVERE FRAME, SUSPENSION AND TIRE DAMAGE MAY RESULT TO THE VEHICLE!</b></p> <p><b>** ICON VEHICLE DYNAMICS RECOMMENDS THAT YOU EXERCISE EXTREME CAUTION WHEN WORKING UNDER A VEHICLE THAT IS SUPPORTED WITH JACK STANDS.</b></p> <p><b>** ICON VEHICLE DYNAMICS RECOMMENDS ALL INSTALLATION TO BE PERFORMED BY A PROFESSIONAL SHOP/SERVICE TECHNICIAN. PRODUCT FAILURE CAUSED BY IMPROPER INSTALLATION WILL NOT BE COVERED UNDER ICON'S WARRANTY POLICY.</b></p>

## INSTALLATION

- Using a properly rated jack, raise the front of the vehicle and support the frame rails with jack stands. Ensure the jack stands are secure and set properly before lowering the jack. NEVER WORK UNDER AN UNSUPPORTED VEHICLE. Remove the front wheels.
- Using a floor jack under the front end, slightly raise the front axle housing to remove the weight of the axle off the bolt. Remove the lower shock bolt. (Make sure the axle is well supported)
- Use a 16MM to remove the upper shock stem nut and remove the OEM shock.
- Use the supplied 3/8" x 1.0" bolt, nut and washers to locate the lower shock doubler bracket (124021) in the correct location outward of the OEM shock mount. There is a factory hole for the 3/8" bolt. [FIGURE 1]

FIG.1

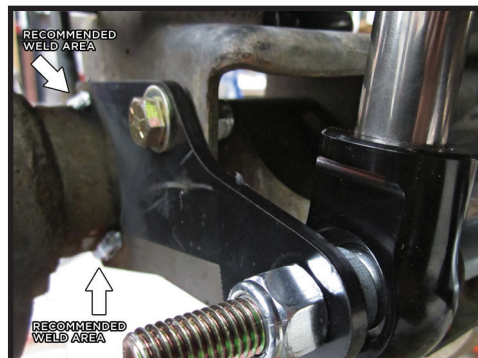

**5.** Line up the doubler plate eyelet and the OEM shock mount by sliding the supplied 1/2" X 4.5" bolt through the doubler plate and the OEM shock mount. Tighten the 3/8" locator bolt to secure the doubler plate in position.

**6.** Use the (159007) weld sleeve to keep the space between the doubler plate and OEM shock as well as the (139004) spacer sleeve to keep the space between the OEM shock mount tabs. Mark on the axle to sand. Remove bracket and sand to bare metal then reinstall bracket and spacers. Weld the doubler plate to the axle housing, a professional welder is highly recommended! [FIGURE 2]

NOTE: Failure to use weld sleeve may result in inadequate spacing.



FIG.2

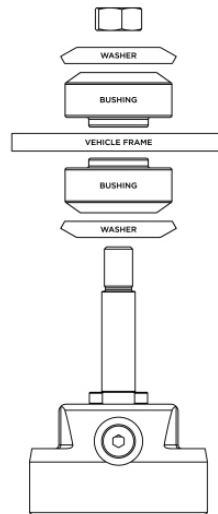

FIG.3

**7.** Spray paint the welded portion of the (124021) doubler plate and factory axle housing to prevent corrosion.

**8.** Install the shock between the doubler plate and the outside of the OEM shock mount. Use the provided spacer sleeve to fill the void between the OEM shock tabs. Install hardware in the following order with the head of the bolt towards the wheel: 1/2" x 4.5" bolt, 1/2" washer, (124021) doubler plate, heim spacer, shock rod end, heim spacer, OEM shock tab, (139004) spacer sleeve, OEM shock tab, 1/2" washer, 1/2" lock nut. [Torque to 65 ft-lbs] [FIGURE 3]

**9.** Use a jack to lower the axle housing far enough to slide the top of the shock into position in the OEM shock location. Install stem hardware as seen in diagram. Raise axle housing to aid with stem installation into the shock mount. Install the lock nut until lock is engaged. Do not overtighten bushing assembly as this can lead to premature bushing wear. Failure caused by incorrect installation of bushings is not covered under icon's warranty policy. [SEE DIAGRAM]



NOTE: 2012-2018 Models will require trimming of the plastic box located directly above the passenger side upper shock mount in order to gain access to the upper shock mount nut. [FIGURE 4]



FIG.4

**10.** If desired, trim the plastic fender liner to leave the remote reservoir exposed. [FIGURE 5 & 6]

FIG.5

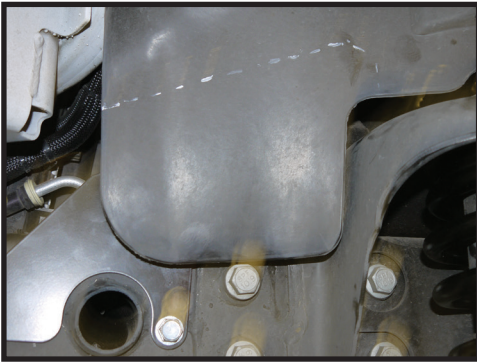

FIG.6



**11.** Orient the reservoir mounting bracket on frame rail forward of the coil bucket and mark center of the 2 holes. [FIGURE 7]

FIG.7



FIG.8

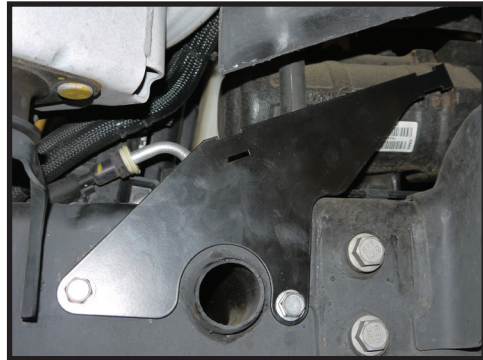

**12.** Inspect the opposite side of the frame rail, checking for any hoses or lines that have to be temporarily removed or held out of the way. Center punch and drill to 21/64”.

**13.** Use a 9/16” to thread the supplied 3/8” x 3/4” self tapping bolts into the frame rail, a minimum 2 full rotations.

**14.** Remove the 3/8” x 3/4” self tap bolt and secure the remote reservoir bracket. [Torque to 30ft-lbs] It's optional to trim the plastic fender liner so that the reservoir is completely exposed. [FIGURE 8]

**15.** Place the reservoir in the reservoir mounting bracket with the ICON Shield logo orientated up into the fender well and secure the reservoir with the supplied 1/2” hose clamps using an 8mm nut driver. Do not overtighten hose clamps. [FIGURE 9]

FIG.9



**16.** Repeat steps 2-15 for opposite side.

**17.** Reinstall the wheels and lower the vehicle back to the ground. [Torque lugs to factory spec]

***VERIFY ALL FASTENERS ARE PROPERLY TORQUED BEFORE DRIVING VEHICLE.***

***RETORQUE ALL NUTS, BOLTS AND LUGS AFTER 100 MILES AND PERIODICALLY THEREAFTER.***

## 2.5 VS SERIES SHOCK & COILOVER TECHNICAL INFORMATION

### MAINTENANCE

ICON shock absorbers are a high quality rebuildable race style shock absorber designed for optimal performance. With a unit of this caliber on your vehicle, routine maintenance is required to keep them looking and operating in like new condition. Residual oil and assembly lube may be present at all seal paths from the factory out of the box and is considered normal. Pooling of oil however is not acceptable at any time and one should contact the ICON dealer where purchased.

**BELOW ARE GUIDELINES BASED ON HOW YOU USE YOUR VEHICLE BUT YOUR MILEAGE MAY VARY:**

#### **STREET USE:**

- Send in for factory servicing every 40,000 miles or if a leak develops, ride quality decreases, or they begin to make excessive noise.
- Remove any buildup of road salt, mud, or debris from shocks and coil springs anytime accrued
- Clean with mild soap and water with each oil change or anytime you notice build up.
- Wax the cylinders yearly with automotive wax to prevent corrosion.
- Check nitrogen pressure yearly. (252004 charge needle assembly available at any ICON distributor)
- Check bearings for excessive wear yearly.
- **DO NOT** apply any type of lube to the upper and lower bearings.

#### **STREET/DIRT:**

- Send in for factory servicing every 15,000 miles or if a leak develops, ride quality decreases, or they begin to make excessive noise.
- Clean with mild soap and water with each oil change, offroad trip, or anytime you notice build up.
- Wax the cylinders yearly with automotive wax to prevent corrosion.
- Check nitrogen pressure each dirt outing. (252004 charge needle assembly available at any ICON distributor)
- Check bearings for excessive wear yearly.
- **DO NOT** apply any type of lube to the upper and lower bearings.

#### **DIRT USE:**

- Send in for factory servicing every 1,000 miles.
- Check nitrogen pressure each outing. (252004 charge needle assembly available at any ICON distributor)
- Remove any buildup of mud or debris from shocks and coil springs after every outing.

#### **SELF-SERVICE:**

- Contact ICON for service kits & tools at (951) 689-4266.

### PRODUCT REGISTRATION

Please visit: <http://www.iconvehicledynamics.com/tech-support/registration/> to register your product.

### ICON VEHICLE DYNAMICS SHOCK ABSORBER WARRANTY

This shock absorber has a 1 year warranty against any manufacturer's defects. If a shock fails within the initial year of ownership, the shock must be shipped to ICON Vehicle Dynamics for inspection and service. If a shock is inspected and it has been determined the shock failed due to neglect, damage caused by improper installation or any other reason besides "normal wear and tear", the owner of said shock is responsible for all service costs. This includes labor, parts, and shipping.

ICON Vehicle Dynamics warrants to the original retail purchaser who owns the vehicle on which the product was originally installed. ICON Vehicle Dynamics does not warrant the product for finish, alterations, modifications and/or installation contrary to ICON Vehicle Dynamics instructions. ICON Vehicle Dynamics products are not designed, nor are they intended to be installed on vehicles used in race applications, for racing purposes or for similar activities. (A "race" is defined as any contest between two or more vehicles, or a contest of one or more vehicles against the clock, whether or not such contest is for a prize). This warranty does not include coverage for police or taxi vehicles, race vehicles, or vehicles used for government or commercial purposes. Also excluded from this warranty are sales outside of the United States of America and Canada.

ICON Vehicle Dynamics' obligation under this warranty is limited to the repair or replacement, at ICON Vehicle Dynamics' discretion, of the defective product. Any and all costs of removal, installation or re-installation, freight charges and incidental or consequential damages are expressly excluded from this warranty. Items that are subject to wear are not considered defective when worn and are not covered.

ICON Vehicle Dynamics components must be installed as a complete kit as shown in our current application guide. Any substitutions or exemptions of required components will immediately void the warranty. Some finish damage may happen to parts during shipping and is not covered under warranty.

This warranty is expressly in lieu of all other warranties expressed or implied. This warranty shall not apply to any product that has been improperly installed, modified or customized subject to accident, negligence, abuse or misuse.

To send a shock in for warranty please visit our website <http://www.iconvehicledynamics.com/tech-support/shock-service/>



**ICON VEHICLE DYNAMICS®**  
PERFORMANCE SUSPENSION SYSTEMS AND SHOCK ABSORBERS

7929 Lincoln Ave. Riverside, CA 92504 Phone: 951.689.ICON Fax: 951.689.1016  
[www.iconvehicledynamics.com](http://www.iconvehicledynamics.com)



**FOLLOW US ON FACEBOOK!**

