

FORMED HD RUNNING BOARDS

(2018-2024+ WRANGLER JL - 4 DOOR)

INSTALLATION INSTRUCTIONS

CONTENTS

- (1) LH Running Board
- (1) RH Running Board
- (1) LH Front Bracket [DF]
- (1) LH Center Bracket [DC]
- (1) LH Rear Bracket [DR]
- (1) RH Front Bracket [PF]
- (1) RH Center Bracket [PC]
- (1) RH Rear Bracket [PR]
- (12) M8 x 25mm Combo Bolts
- (6) M8 x 35mm Hex Bolts
- (6) M8 Flat Washers
- (6) M8 Lock Washers
- (12) M6 x 25mm Hex Bolts
- (24) M6 Flat Washers
- (12) M6 Lock Nuts

TOOLS REQUIRED

- 10mm Wrench/Socket
- 13mm Wrench/Socket
- Ratchet

SKU # J250629
Edited:23/06/2025

STEP 1

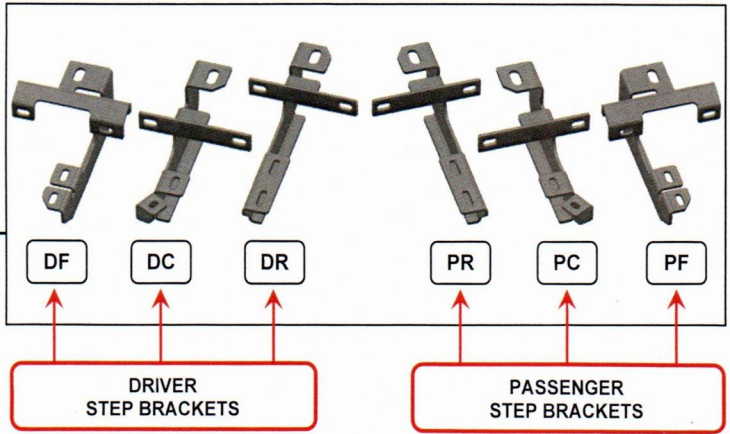

Mounting Brackets look similar but are unique. Please identify each mounting bracket using the engraved location identifier.

DF: Driver Front
 DC: Driver Center
 DR: Driver Rear

PF: Passenger Front
 PC: Passenger Center
 PR: Passenger Rear

STEP 2

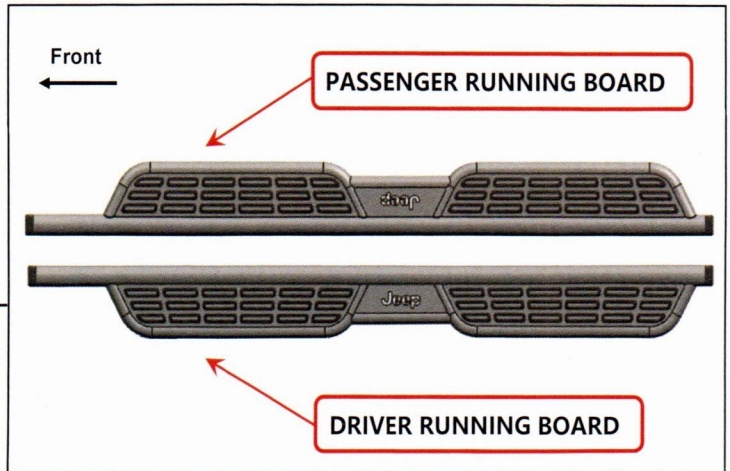

Identify each running board by identifier on the front. Notice: "D" for Driver/Left Side; "P" for Passenger/Right Side.

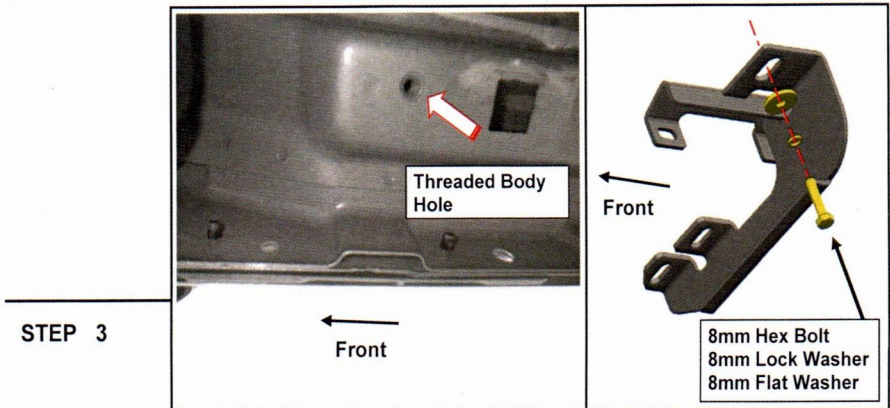

Start installation toward the front of the Passenger/Right side of the vehicle.

Loosely fit the (1) Passenger Front bracket to the vehicle threaded body hole using (1) M8 x 35mm hex bolt, (1) M8 lock washer, and (1) M8 flat washer. Do not fully tighten to allow for later adjustments. Repeat this step for all step brackets.

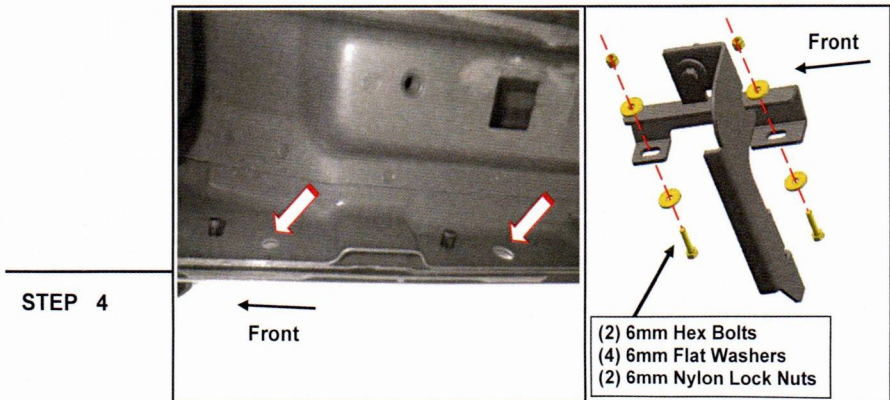

Loosely fit the Passenger Front bracket to the **vehicle pinch weld** using (2) M6 x 25mm hex bolts, (4) M6 flat washers, and (2) M6 nylon lock nuts. Do not fully tighten to allow for later adjustments. Repeat this step for all step brackets.

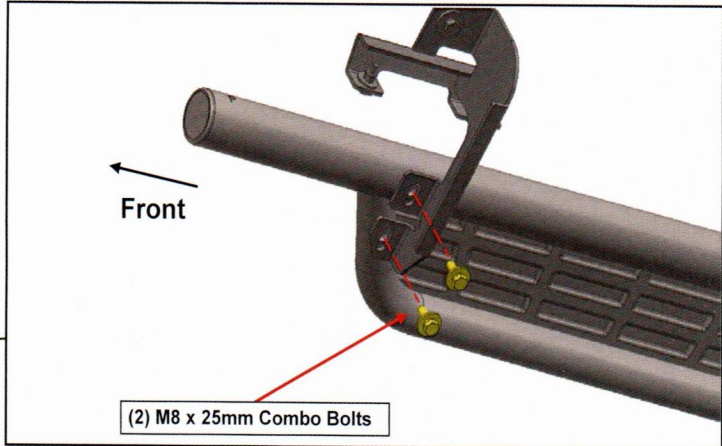

STEP 5

With all brackets loosely mounted to the vehicle, fit the running board onto the brackets, and loosely secure into place using (6) M8 x 25mm combo bolts.

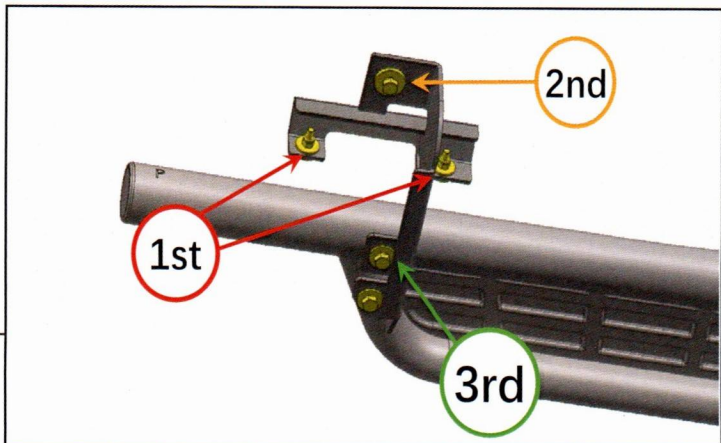

STEP 6

Tighten the mounting brackets to the vehicle (M6 first, then M8). Adjust the running board to the desired angle, and tighten the M8 combo bolts to secure the step into place. See photo for tightening order visual.

Repeat steps 1 - 6 for the remaining running board.

Installation is now complete.