



TC5 RUNNING BOARDS

(2007-2018 WRANGLER JK 4 DOOR)

INSTALLATION INSTRUCTIONS

CONTENTS

- (1) LH Running Board
- (1) RH Running Board
- (3) LH Step Brackets [DF, DC, DR]
- (3) LH Reinforcement Brackets [DF, DC, DR]
- (3) RH Step Brackets [PF, DC, PR]
- (3) RH Reinforcement Brackets [PF, DC, PR]
- (6) M10 x 35mm Hex Bolts
- (6) M10 x 30mm Hex Bolts
- (6) M10 x 34mm OD x 3mm Flat Washers
- (12) M10 x 20mm OD x 2mm Flat Washers
- (6) M10 Lock Washers
- (6) M10 Nylon Lock Nuts
- (6) M10 Nut Plates
- (10) M8 x 25mm Combo Bolts
- (6) M8 x 35mm Hex Bolts
- (6) M8 Lock Washers
- (6) M8 x 28mm OD x 3mm Flat Washers
- (12) M6 x 25mm Hex Bolts
- (24) M6 x 22mm OD x 2mm Flat Washers
- (12) M6 Nylon Lock Nuts

TOOLS REQUIRED

10mm, 13mm, 16mm, 17mm
Sockets/Wrenches
Ratchet

SKU # J243512

Edited:04/07/2025

BARRICADE

STEP 1

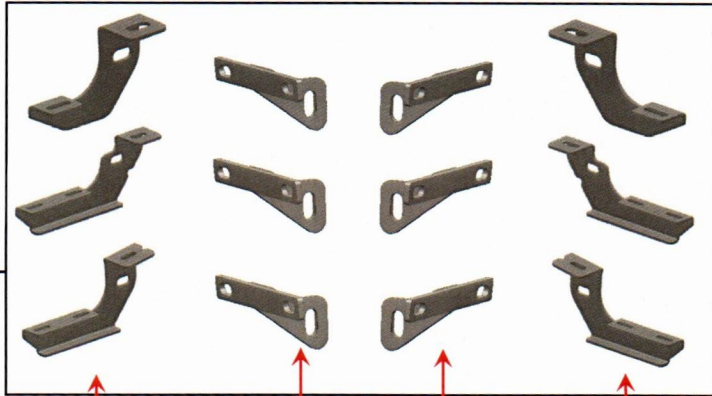

DRIVER SIDE
STEP BRACKETS

DRIVER SIDE
REINFORCEMENT
BRACKETS

PASSENGER SIDE
REINFORCEMENT
BRACKETS

PASSENGER SIDE
STEP BRACKETS

Please identify each mounting bracket using the engraved location identifier. **Notice:** Mounting Brackets look very similar but are unique. The Reinforcement Brackets are the same in the same side..

DF: Driver Front
DC: Driver Center
DR: Drier Rear

PF: Passenger Front
PC: Passenger Center
PR: Passenger Rear

STEP 2

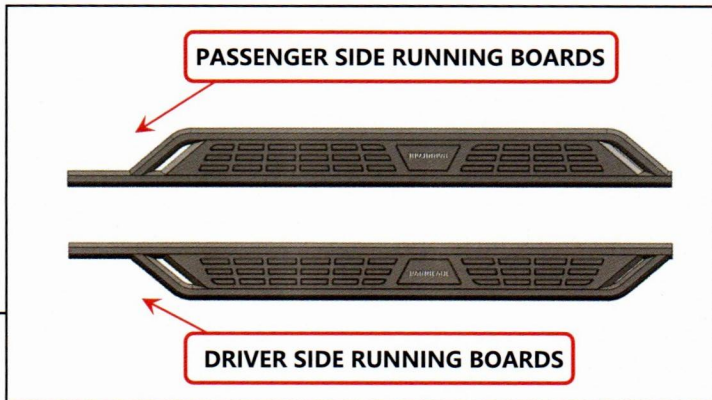

Identify each running board by identifier on the front. **Notice:** "D" for Driver/Left Side; "P" for Passenger/Right Side

BARRICADE

Determine if the vehicle has an open floor panel or a threaded hole in the floor panel.

Vehicles with open mounting location follow Step 3.1:

Vehicles with factory threaded hole in floor panel follow Step 3.2:

STEP 3.1

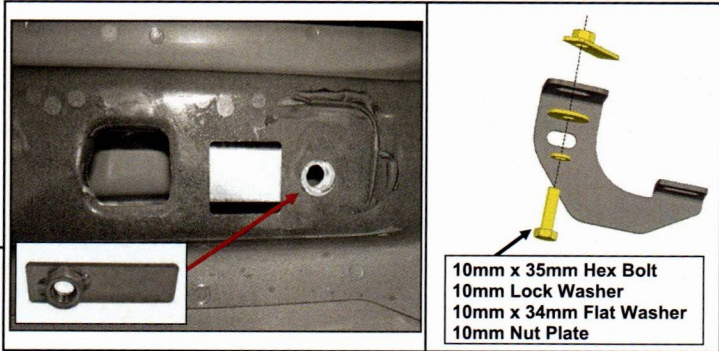

Start installation toward the front of the Passenger/Right side of the vehicle.

Insert (1) M10 nut plates into the large square opening in the floor panel. Line up the threaded nut with the hole in between the pair of holes on the pinch weld.

Loosely fit the (1) Passenger Front step bracket to the M10 nut plates, using (1) M10 x 35mm hex bolt, (1) M10 lock washer, and (1) M10 x 34mm flat washer [large OD]. Do not fully tighten to allow for later adjustments. Repeat this step for all step brackets.

STEP 3.2

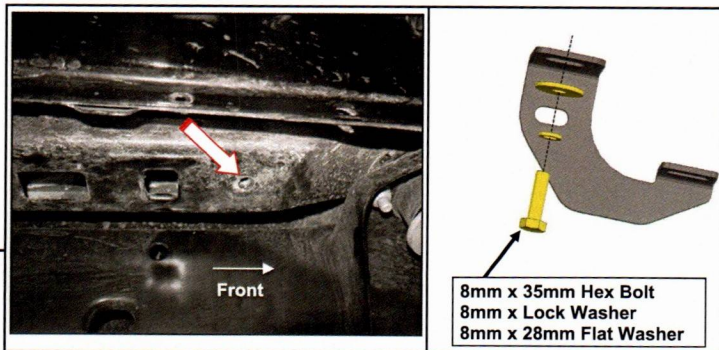

Loosely fit the (1) Passenger Front step bracket to the vehicle threaded body hole using (1) M8 x 35mm hex bolt, (1) M8 lock washer, and (1) M8 x 28mm flat washer. Do not fully tighten to allow for later adjustments. Repeat this step for all step brackets.

BARRICADE

STEP 4

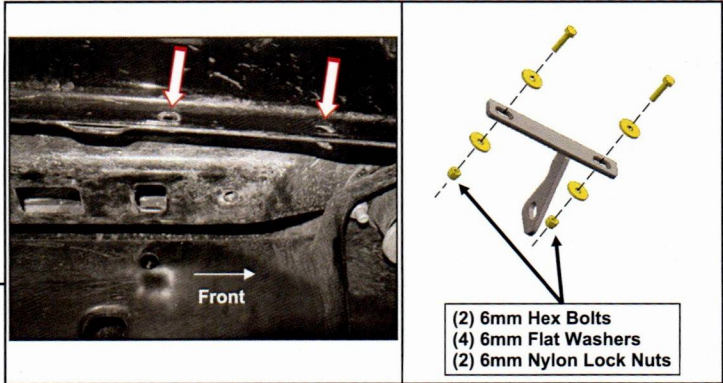

Loosely fit the Passenger Front reinforcement bracket to the **inside of the vehicle pinch weld** using (2) M6 x 25mm hex bolts, (4) M6 flat washers, and (2) M6 lock nuts. Do not fully tighten to allow for later adjustments. Repeat this step for all Passenger reinforcement brackets.

STEP 5

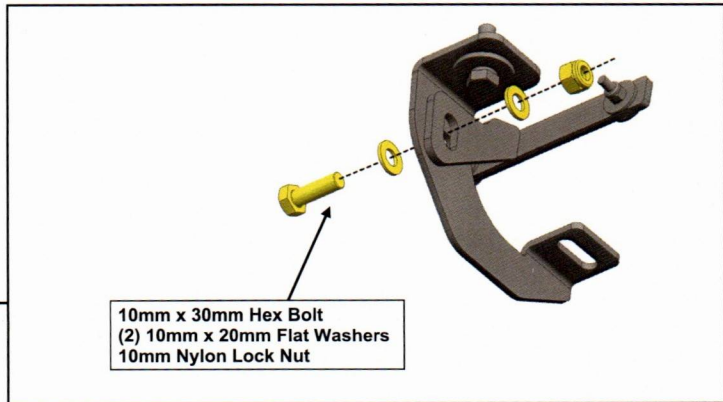

Loosely connect the (1) Passenger step bracket to the (1) Passenger reinforcement bracket using (1) M10 x 30mm hex bolt, (2) M10 x 20mm flat washers, and (1) M10 lock nut.

Repeat this step for all step brackets.

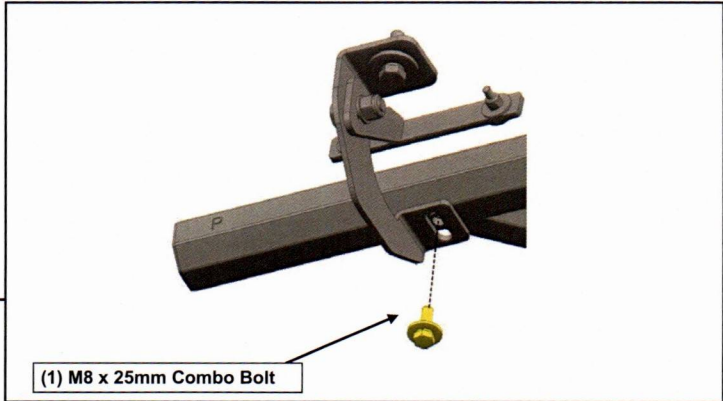

STEP 6

With all brackets loosely mounted to the vehicle, fit the running board onto the **front bracket**, and loosely secure into place using (1) M8 x 25mm combo bolt.

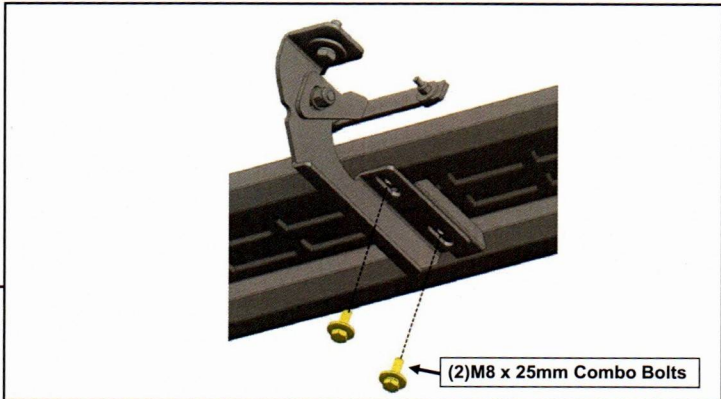

STEP 7

Then fit the running board onto the **center bracket**, and loosely secure into place using (2) M8 x 25mm combo bolts Repeat the step for PS rear step bracket.

BARRICADE

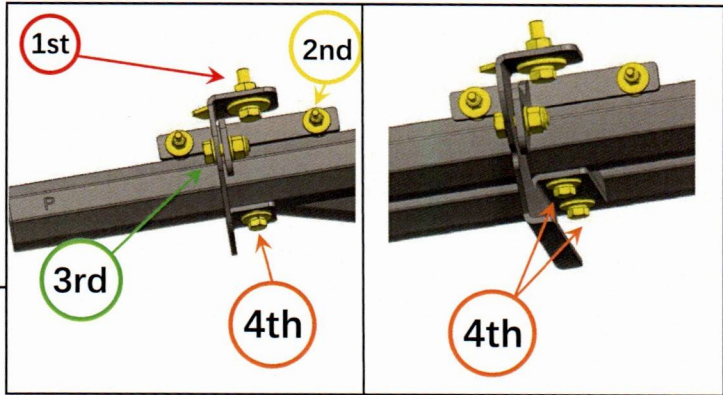

STEP 8

Tighten the mounting brackets to the vehicle. Adjust the running board to the desired angle, and tighten the bolts to secure the step into place. See photo for tightening order visual.

Repeat steps 1-8 for the remaining running board.

Installation is now complete.