

STEP 4

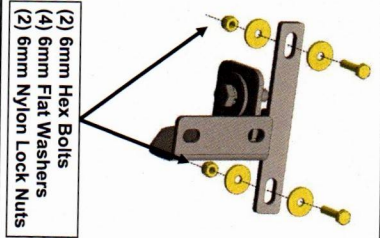

Loosely fit the Passenger Front reinforcement bracket to the **inside of the vehicle pinch weld** using (2) M6 x 25mm hex bolts, (4) M6 flat washers, and (2) M6 lock nuts. Do not fully tighten to allow for later adjustments. Repeat this step for all Passenger reinforcement brackets.

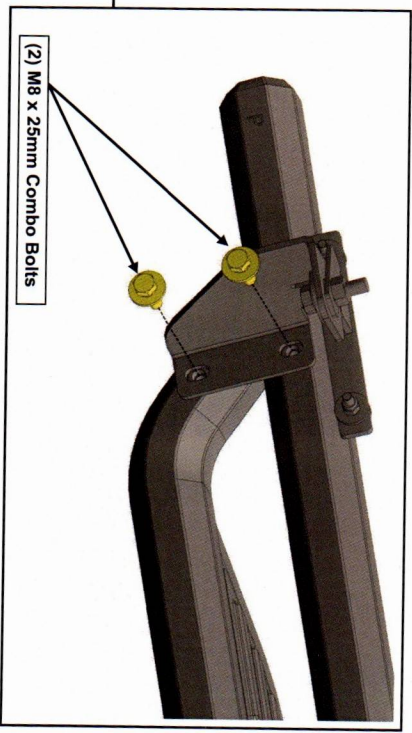

STEP 5

With all brackets loosely mounted to the vehicle, fit the running board onto the **front bracket**, and loosely secure into place using (2) M8 x 25mm combo bolts.

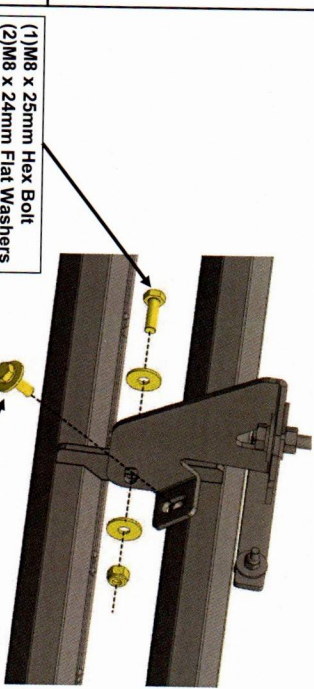

STEP 6

Then fit the running board onto the **center bracket**, and loosely secure into place using (1) M8 x 25mm combo bolt, (1) M8 x 25mm hex bolt, (2) M8 x 24mm flat washer, (1) M8 lock nut. Repeat the step for PS rear step bracket.

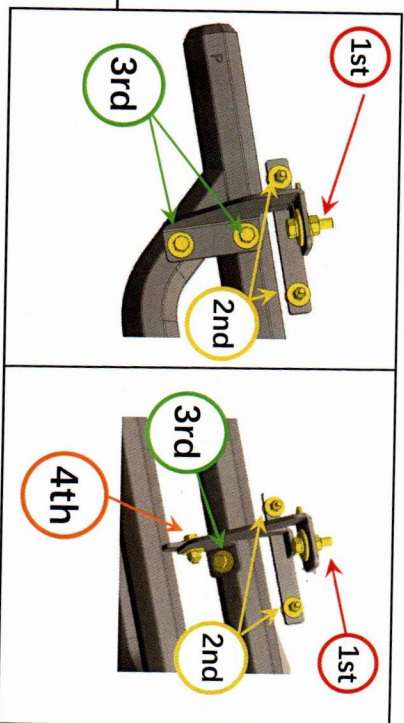

STEP 7

Tighten the mounting brackets to the vehicle. Adjust the running board to the desired angle, and tighten the bolts to secure the step into place. See photo for tightening order visual.

Repeat steps 1-7 for the remaining running board.
Installation is now complete.

BARRICADE

Determine if the vehicle has an open floor panel or a threaded hole in the floor panel.

Vehicles with open mounting location follow Step 3.1:

Vehicles with factory threaded hole in floor panel follow Step 3.2:

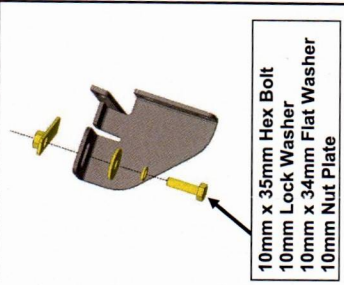
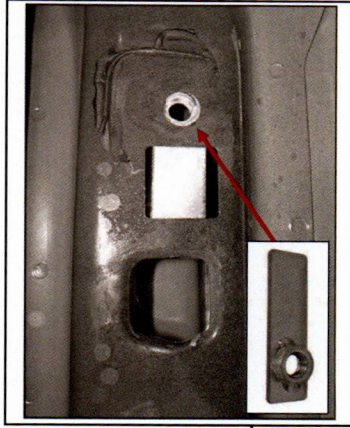

STEP 3.1

- 10mm x 35mm Hex Bolt
- 10mm Lock Washer
- 10mm x 34mm Flat Washer
- 10mm Nut Plate

Start installation toward the front of the Passenger/Right side of the vehicle.

Insert (1) M10 nut plates into the large square opening in the floor panel. Line up the threaded nut with the hole in between the pair of holes on the pinch weld.

Loosely fit the (1) Passenger Front step bracket to the M10 nut plates, using (1) M10 x 35mm hex bolt, (1) M10 lock washer, and (1) M10 x 34mm flat washer. Do not fully tighten to allow for later adjustments. Repeat this step for all step brackets.

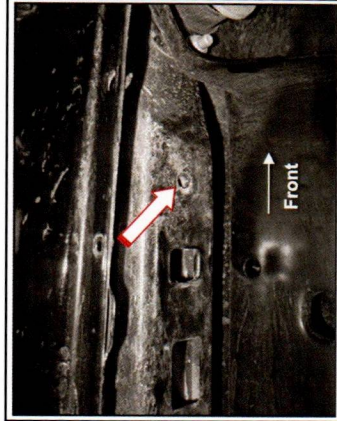

STEP 3.2

- 8mm x 35mm Hex Bolt
- 8mm x 28mm Lock Washer
- 8mm x 20mm Flat Washer

Loosely fit the (1) Passenger Front step bracket to the vehicle threaded body hole using (1) M8 x 35mm hex bolt, (1) M8 lock washer, and (1) M8 x 28mm flat washer. Do not fully tighten to allow for later adjustments. Repeat this step for all step brackets.

STEP 1

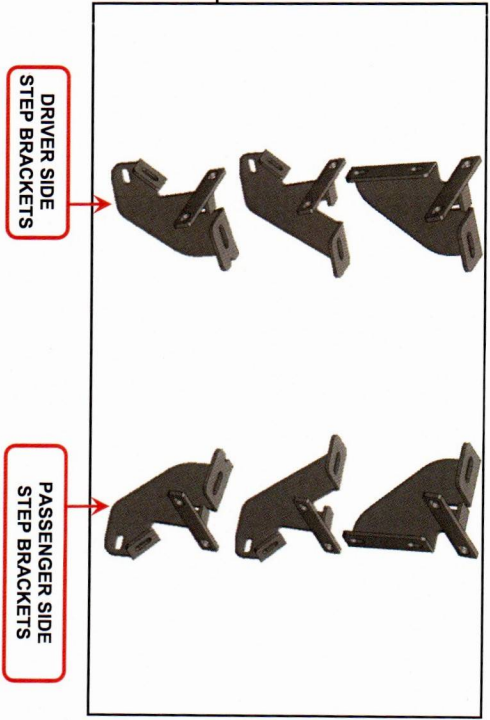

Please identify each mounting bracket using the engraved location identifier. Notice: Mounting Brackets look very similar but are unique.

DF: Driver Front
DC: Driver Center
DR: Driver Rear

PF: Passenger Front
PC: Passenger Center
PR: Passenger Rear

STEP 2

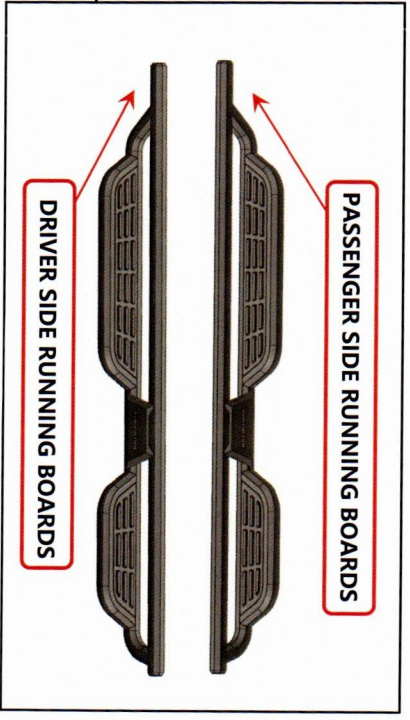

Identify each running board by identifier on the front. Notice: "D" for Driver/Left Side; "P" for Passenger/Right Side



TC4 HD RUNNING BOARDS

(2007-2018 WRANGLER JK 4 DOOR)

INSTALLATION INSTRUCTIONS

CONTENTS

- (1) LH Running Board
- (1) RH Running Board
- (3) LH Step Brackets [DF, DC, DR]
- (3) RH Step Brackets [PF, DC, PR]
- (6) M10 x 35mm Hex Bolts
- (6) M10 x 34mm OD x 3mm Flat Washers
- (6) M10 Lock Washers
- (6) M10 Nut Plates
- (8) M8 x 25mm Combo Bolts
- (6) M8 x 35mm Hex Bolts
- (4) M8 x 25mm Hex Bolts
- (6) M8 Lock Washers
- (4) M8 Lock Nut
- (6) M8 x 28mm OD x 3mm Flat Washers
- (8) M8 x 24mm OD x 2mm Flat Washers
- (12) M6 x 25mm Hex Bolts
- (24) M6 x 22mm OD x 2mm Flat Washers
- (12) M6 Nylon Lock Nuts

TOOLS REQUIRED

- 10mm, 13mm, 16mm, 17mm
Sockets/Wrenches
- Ratchet

SKU # J241938
Edited:03/27/2025