

PARTS LIST: J195717

| | | | |
|---|--|---|----------------------------------|
| 1 | Skid Plate | 4 | 10mm Lock Washers |
| 1 | Driver/Left JL/JT Skid Plate Bracket | 4 | 10mm Hex Nuts |
| 1 | Passenger/Right JL/JT Skid Plate Bracket | 6 | 8mm x 25mm Button Head Bolts |
| 1 | Driver/Left JK Skid Plate Bracket | 8 | 8mm x 24mm OD x 2mm Flat Washers |
| 1 | Passenger/Right JK Skid Plate Bracket | 6 | 8mm Lock Washers |
| 2 | 10mm Bolt Plates | 2 | 8mm Hex Nuts |
| 2 | 10mm x 35mm Button Head Bolts | 1 | 6mm Hex Wrench |
| 6 | 10mm x 30mm OD x 2.5mm Flat Washers | 1 | 5mm Hex Wrench |

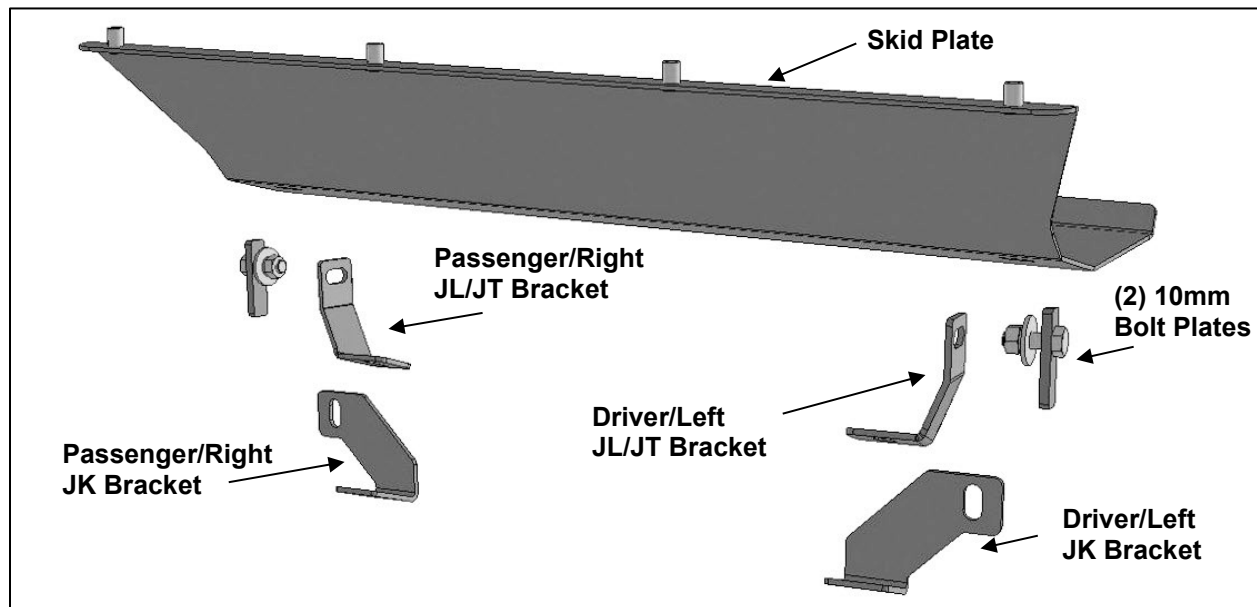

PROCEDURE:

REMOVE CONTENTS FROM BOX. VERIFY ALL PARTS ARE PRESENT. READ INSTRUCTIONS CAREFULLY BEFORE STARTING INSTALLATION. ASSISTANCE IS RECOMMENDED.

1. Start under the front bumper of the vehicle.
2. Determine model for Skid Plate installation
3. **For JK models:**
 - a. Locate the outer hole in the back of the crossmember, **(Figure 1)**.
 - b. Select the driver/left JK Skid Plate Bracket.
 - c. Attach the Bracket to the outer hole in the back of the crossbar with (1) 10mm Button Head Bolt, (2) 10mm Flat Washers, (1) 10mm Lock Washer and (1) 10mm Hex Nut, **(Figures 2—4)**.
 - d. Repeat the previous **Steps** to attach the passenger/right JK Skid Plate Bracket.
 - e. Select the Skid Plate. Attach the Skid Plate to the back of the Bumper with (4) 8mm Button Head Bolts, (4) 8mm Lock Washers and (4) 8mm Flat Washers, **(Figure 8)**.
 - f. Attach the Skid Plate to the Skid Plate Brackets with (2) 8mm Button Head Bolts, (4) 8mm Flat Washers, (2) 8mm Lock Washers and (2) 8mm Hex Nuts, **(Figures 8 & 9)**.

For JL/JT models:

- a. Select (1) 10mm Bolt Plate. Insert the Bolt Plate up into the frame and out the second hex hole up from the bottom, **(Figure 5)**.
- b. Attach the driver/left JL/JT Skid Plate Bracket to the Bolt Plate with (1) 10mm Flat Washer, (1) 10mm Lock Washer and (1) 10mm Hex Nut, **(Figures 6 & 7)**.
- c. Repeat the previous **Steps** to attach the passenger/right JL/JT Skid Plate Bracket.
- d. Select the Skid Plate. Attach the Skid Plate to the back lower rear of the Bumper with (4) 8mm Button Head Bolts, (4) 8mm Lock Washers and (4) 8mm Flat Washers, **(Figure 8)**.
- e. Attach the Skid Plate to the Skid Plate Brackets with (2) 8mm Button Head Bolts, (4) 8mm Flat Washers, (2) 8mm Lock Washers and (2) 8mm Hex Nuts, **(Figure 8)**.

4. Stand back from the vehicle and check to see that the Skid Plate is centered and level on the vehicle and adjust as required. Once properly aligned, fully tighten all hardware.
5. Do periodic inspections of the installation to make sure that all hardware is secure and tight.

To protect your investment, Do not use any type of polish or wax that may contain abrasives that could damage the finish. Mild soap may be used to clean the Skid Plate.

Driver/left Side Installation Pictured

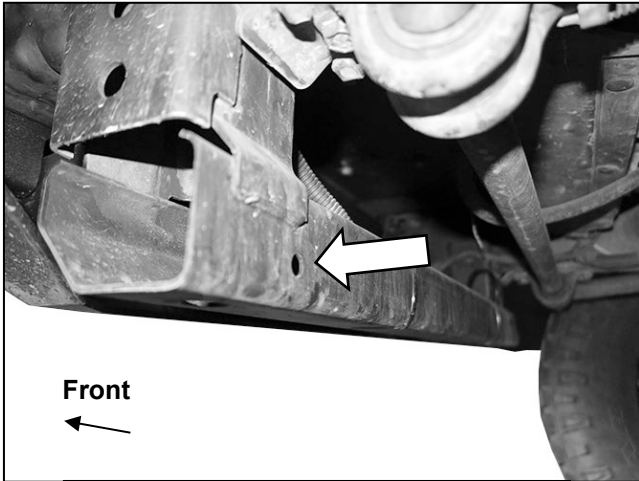

(Fig 1) For JK models, locate the outer hole in the back of the crossbar

10mm Button Head Bolt
(2) 10mm Flat Washers
10mm Lock Washer
10mm Hex Nut

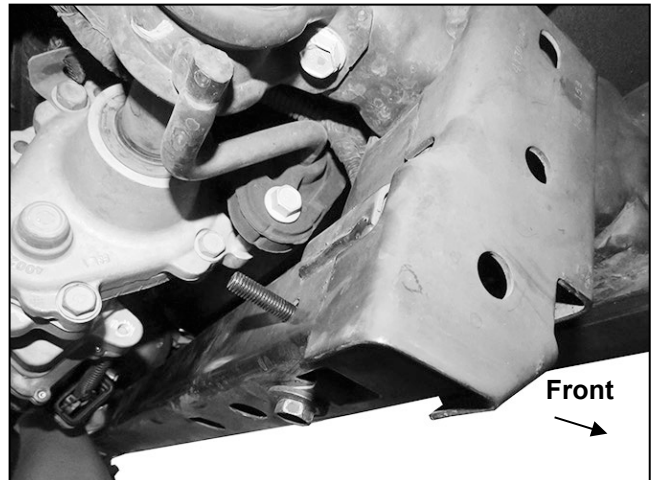

(Fig 2) Insert (1) 10mm x 35mm Button Head Bolt with (1) 10mm Flat Washer into and out the back of the crossbar (passenger/right side pictured)

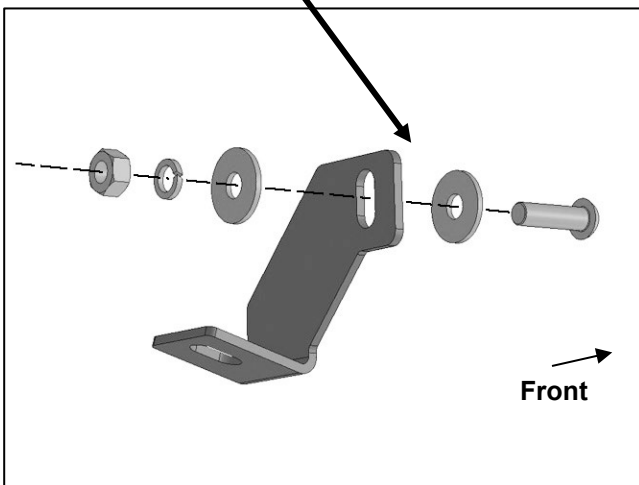

(Fig 3) JK models only, attach driver/left Skid Plate Bracket to the back of the crossbar



(Fig 4) JK models only, driver/left Skid Plate Bracket installed

Driver/left Side Installation Pictured



(Fig 5) For JL and JT models, insert (1) 10mm Bolt Plate into the bottom of the frame and out the hole as pictured

- 10mm Bolt Plate
- 10mm Flat Washer
- 10mm Lock Washer
- 10mm Hex Nut

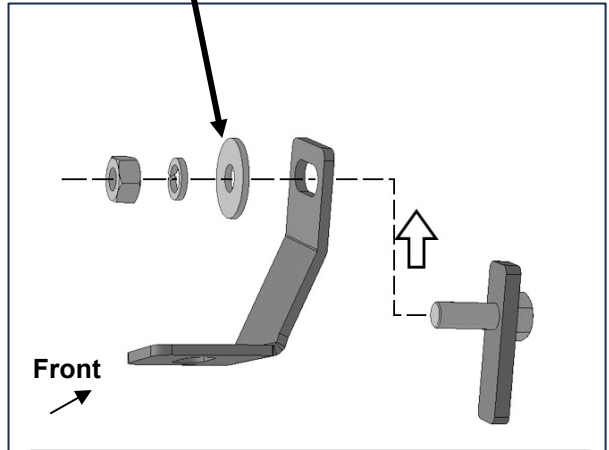

(Fig 6) JL/JT models, attach the driver/left Skid Plate Bracket to the 10mm Bolt Plate

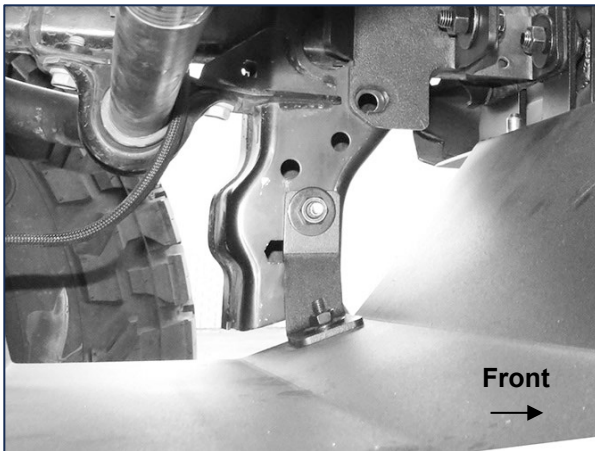

(Fig 7) Driver/left JL/JT mounting Bracket pictured installed with Skid Plate

- (4) 8mm Button Head Bolts
- (4) 8mm Lock Washers
- (4) 8mm Flat Washers

- 8mm Button Head Bolt
- (2) 8mm Flat Washers
- 8mm Lock Washer
- 8mm Hex Nut

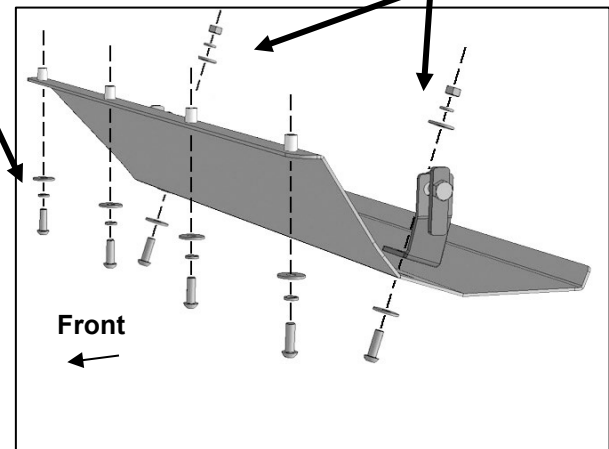

(Fig 8) Attach the top of the Skid Plate to the back of the Bumper. Attach the bottom of the Skid Plate to the Skid Plate Brackets, (JL/JT model installation illustrated)

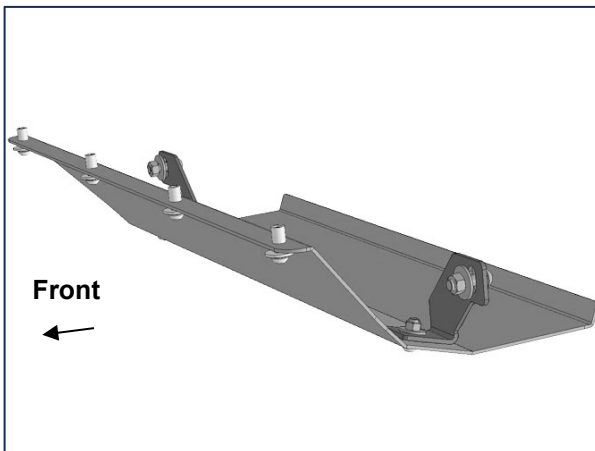

(Fig 9) Example of complete installation on JK model