



---

# TUBULAR DROP STEPS

(2018-2023+ WRANGLER JL - 2 DOOR)

---

## INSTALLATION INSTRUCTIONS

### CONTENTS

---

- (1) LH Side Step
- (1) RH Side Step
- (2) LH Step Brackets [DF, DR]
- (2) LH Reinforcement Brackets [DF, DR]
- (2) RH Step Brackets [PF, PR]
- (2) RH Reinforcement Brackets [PF, PR]
- (4) M10 x 30mm Hex Bolts
- (8) M10 x 24mm OD x 2.2mm Flat Washers
- (4) M10 Nylon Lock Nuts
- (8) M8 x 25mm Combo Bolts
- (4) M8 x 35mm Hex Bolts
- (4) M8 Lock Washers
- (4) M8 x 28mm OD x 3mm Flat Washers
- (8) M6 x 25mm Hex Bolts
- (16) M6 x 22mm OD x 2mm Flat Washers
- (8) M6 Nylon Lock Nuts

### TOOLS REQUIRED

---

10mm, 13mm, 16mm, 17mm  
Sockets/Wrenches  
Ratchet

SKU # J186936

Edited:08/17/2023

## STEP 1

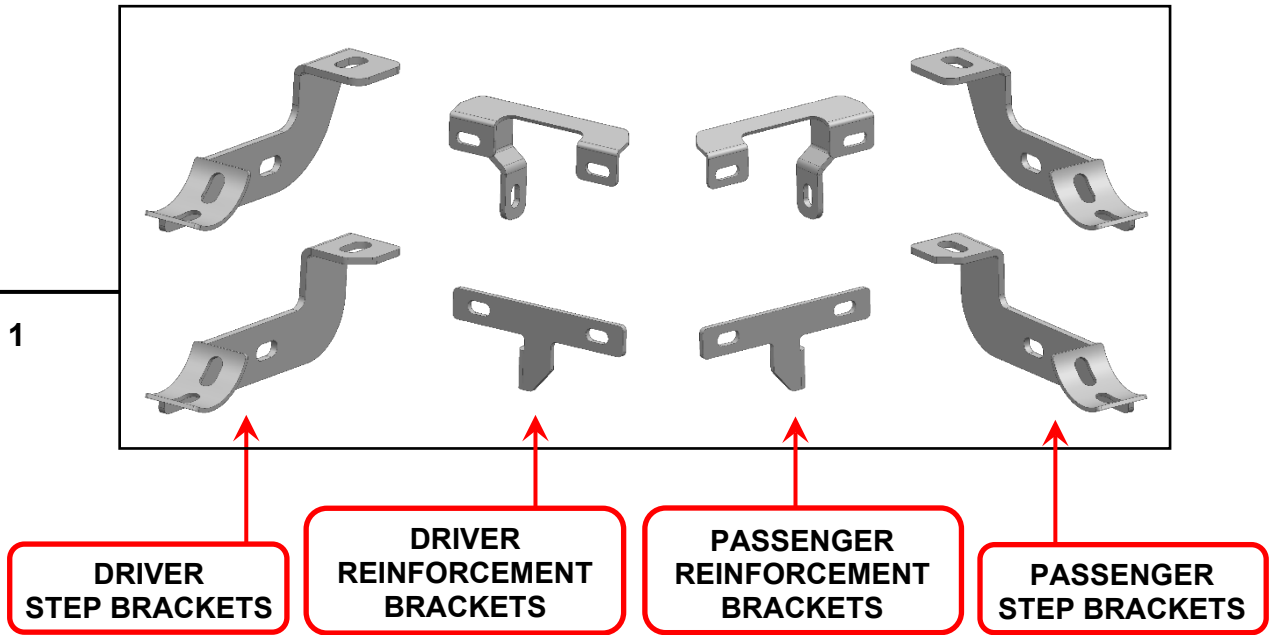

Mounting Brackets look very similar but are unique. Please identify each mounting bracket using the engraved location identifier.

DF: Driver Front  
DR: Driver Rear

PF: Passenger Front  
PR: Passenger Rear

## STEP 2

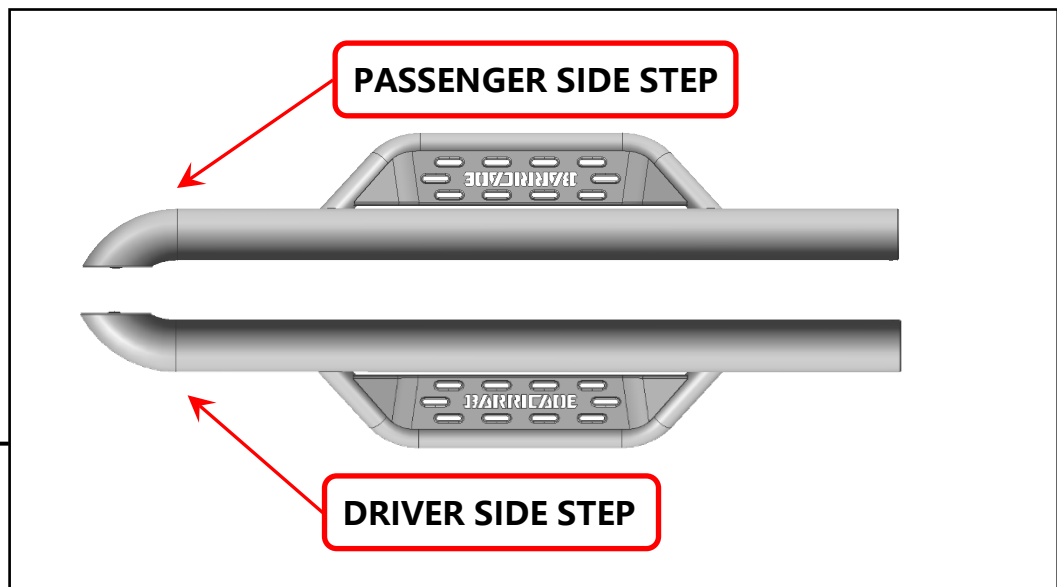

Identify each side step by the curved portion of the step.

## STEP 3

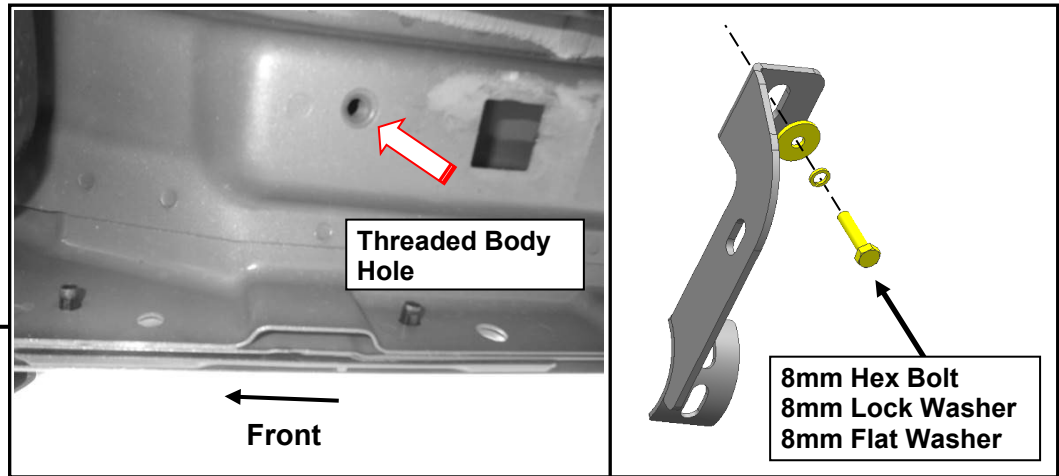

Start installation toward the front of the Passenger/Right side of the vehicle.

Loosely fit the (1) Passenger Front step bracket to the vehicle threaded body hole using (1) M8 x 35mm hex bolt, (1) M8 lock washer, and (1) M8 flat washer. Do not fully tighten to allow for later adjustments. Repeat this step for all step brackets.

## STEP 4

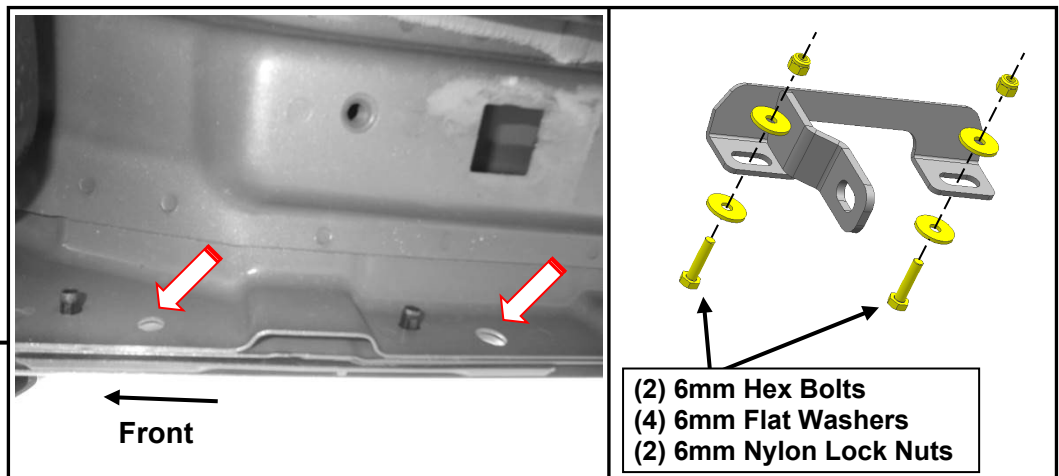

Loosely fit the Passenger Front reinforcement bracket to the **inside of the vehicle pinch weld** using (2) M6 x 25mm hex bolts, (4) M6 flat washers, and (2) M6 nylon lock nuts. Do not fully tighten to allow for later adjustments. Repeat this step for all step brackets.

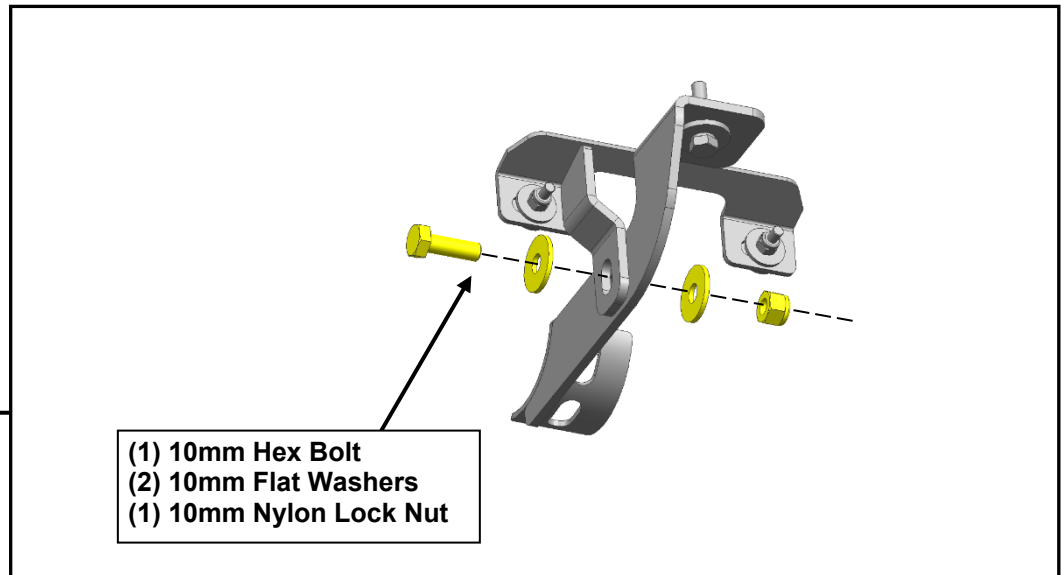

Loosely connect the (1) Passenger step bracket to the (1) Passenger reinforcement bracket using (1) M10 × 30mm hex bolt, (2) M10 flat washers, and (1) M10 nylon lock nut.

Repeat this step for all step brackets.

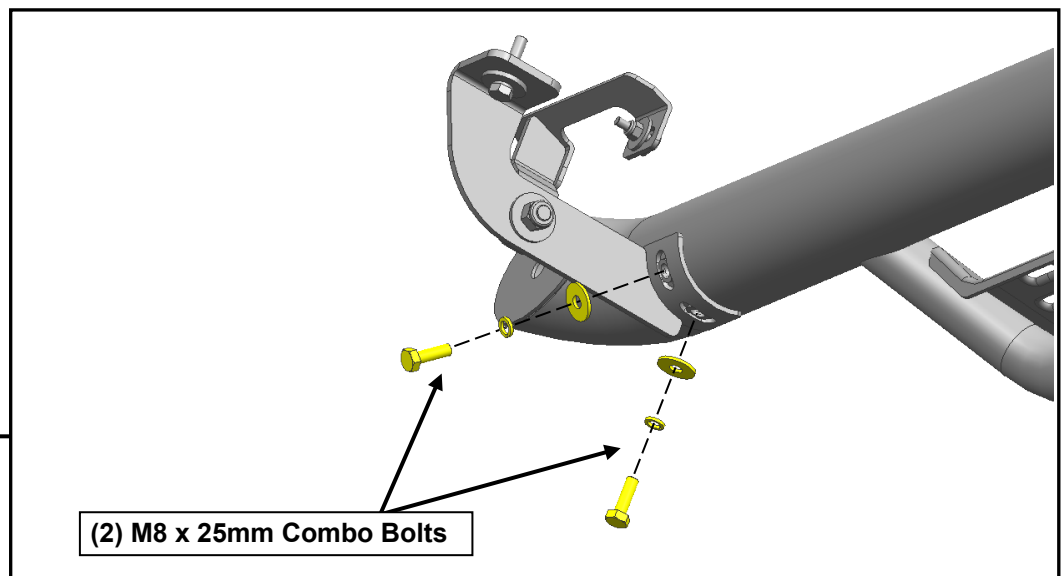

With all brackets loosely mounted to the vehicle, fit the side step onto the brackets, and loosely secure into place using (4) M8 x 25mm combo bolts.

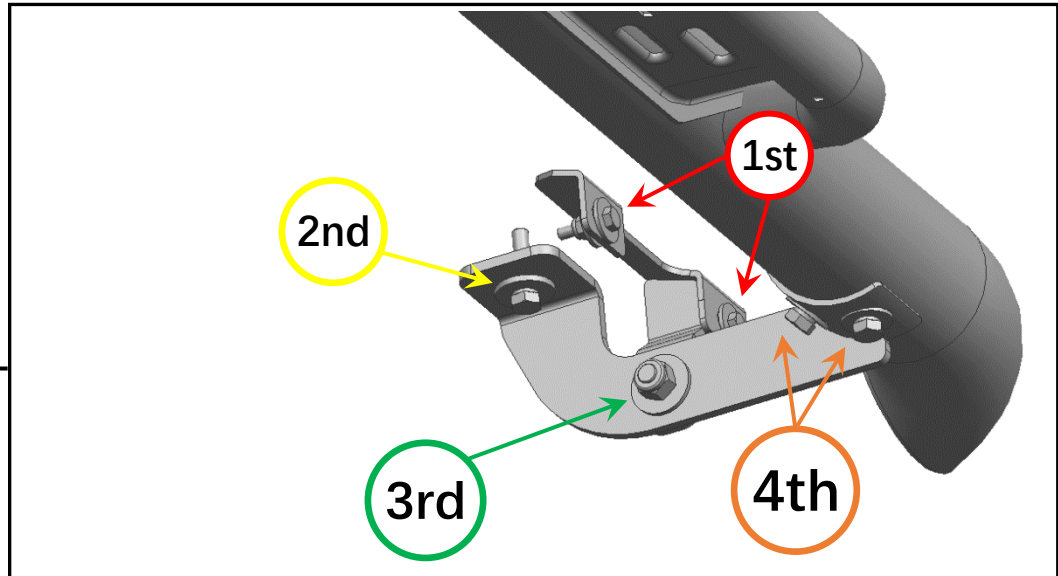

## STEP 7

Tighten the mounting brackets to the vehicle (M6 first, then M8). Tighten the M10 bolt joining the brackets together. Adjust the side step to the desired angle, and tighten the M8 combo bolts to secure the step into place. See photo for tightening order visual.

Repeat steps 1-7 for the remaining side step.

Installation is now complete.