



HD DROP SIDE STEP BARS

(2007-2018 WRANGLER JK 4 DOOR)

INSTALLATION INSTRUCTIONS

CONTENTS

- (1) LH Side Step
- (1) RH Side Step
- (3) LH Step Brackets [DF, DC, DR]
- (3) RH Step Brackets [PF, DC, PR]
- (6) M10 x 35mm Hex Bolts
- (12) M10 x 30mm Hex Bolts
- (6) M10 x 34mm OD x 3mm Flat Washers
- (24) M10 x 28mm OD x 2mm Flat Washers
- (6) M10 Lock Washers
- (12) M10 Nylon Lock Nuts
- (6) M10 Nut Plates
- (6) M8 x 35mm Hex Bolts
- (6) M8 Lock Washers
- (6) M8 x 28mm OD x 3mm Flat Washers
- (12) M6 x 25mm Hex Bolts
- (24) M6 x 22mm OD x 2mm Flat Washers
- (12) M6 Nylon Lock Nuts

TOOLS REQUIRED

- 10mm,13mm,16mm,17mm
- Sockets/Wrenches
- Ratchet

SKU # J150092

Edited:12/25/2023

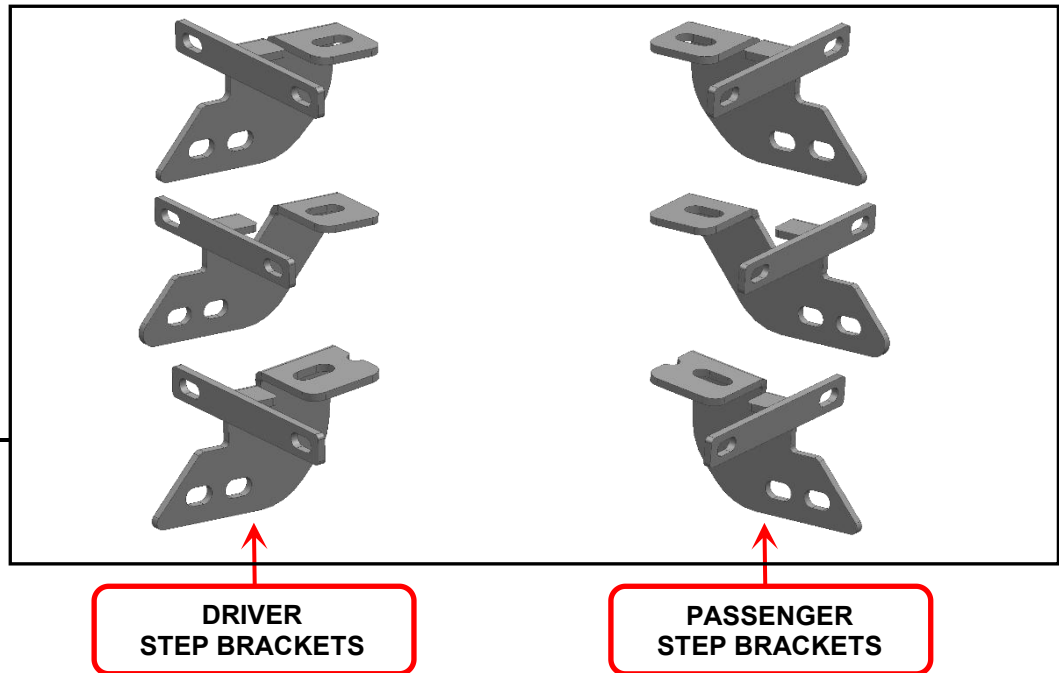
STEP 1

Mounting Brackets look very similar but are unique. Please Identify each mounting bracket using the engraved location identifier.

DF: Driver Front
DC: Driver Center
DR: Driver Rear

PF: Passenger Front
PC: Passenger Center
PR: Passenger Rear

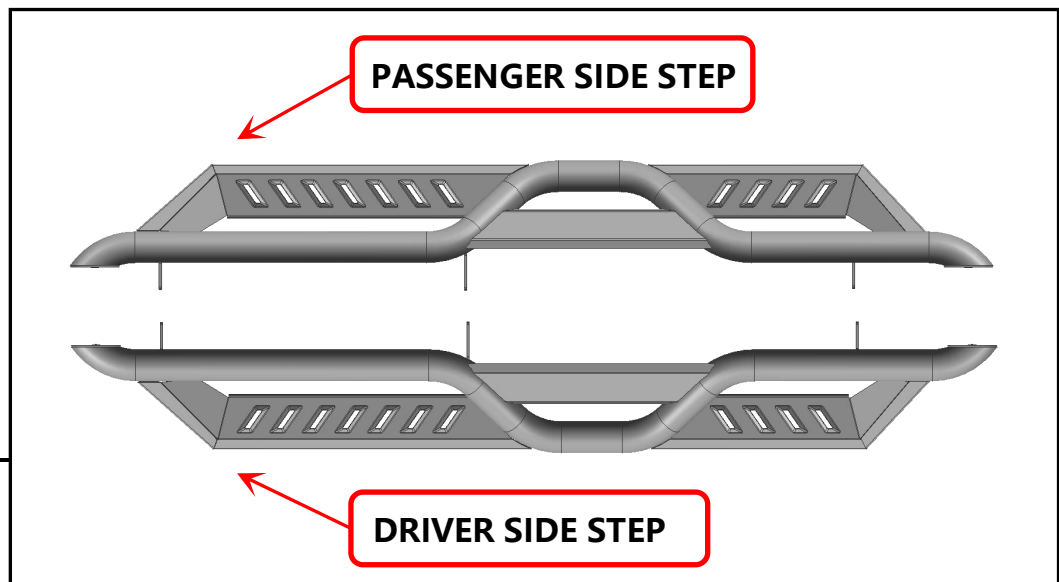
STEP 2

Please identify the Driver Side and Passenger Side Running Board according to the illustration

Determine if the vehicle has an open floor panel or a threaded hole in the floor panel.

Vehicles with open mounting location follow Step 3.1:

Vehicles with factory threaded hole in floor panel follow Step 3.2:

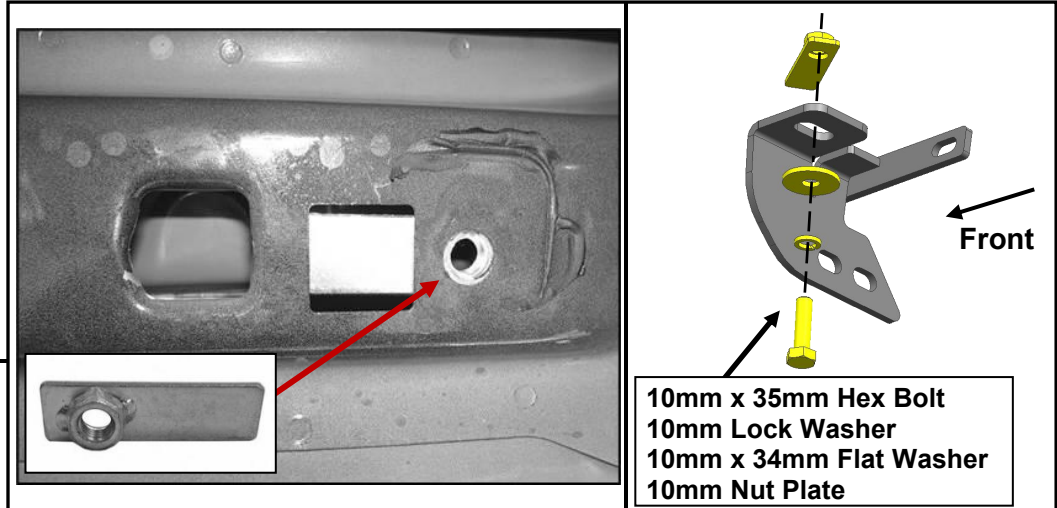
STEP 3.1

Start installation toward the front of the Passenger/Right side of the vehicle.

Insert (1) M10 nut plates into the large square opening in the floor panel. Line up the threaded nut with the hole in between the pair of holes on the pinch weld.

Loosely fit the (1) Passenger Front step bracket to the (1) M10 nut plate, using (1) M10 x 35mm hex bolt, (1) M10 lock washer, and (1) M10 x 34mm flat washer [large OD]. Do not fully tighten to allow for later adjustments. Repeat this step for all step brackets.

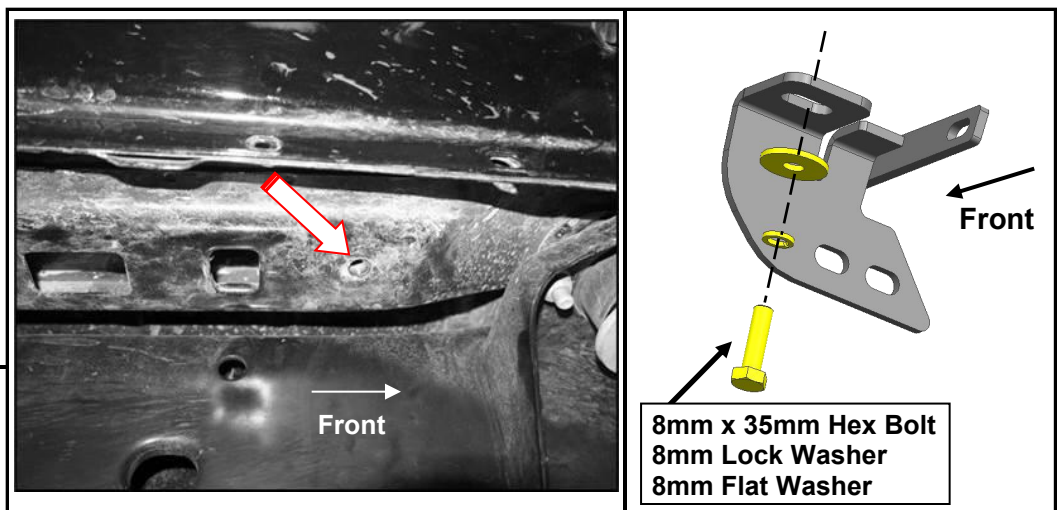
STEP 3.2

Loosely fit the (1) Passenger Front step bracket to the vehicle threaded body hole using (1) M8 x 35mm hex bolt, (1) M8 lock washer, and (1) M8 flat washer. Do not fully tighten to allow for later adjustments. Repeat this step for all step brackets.

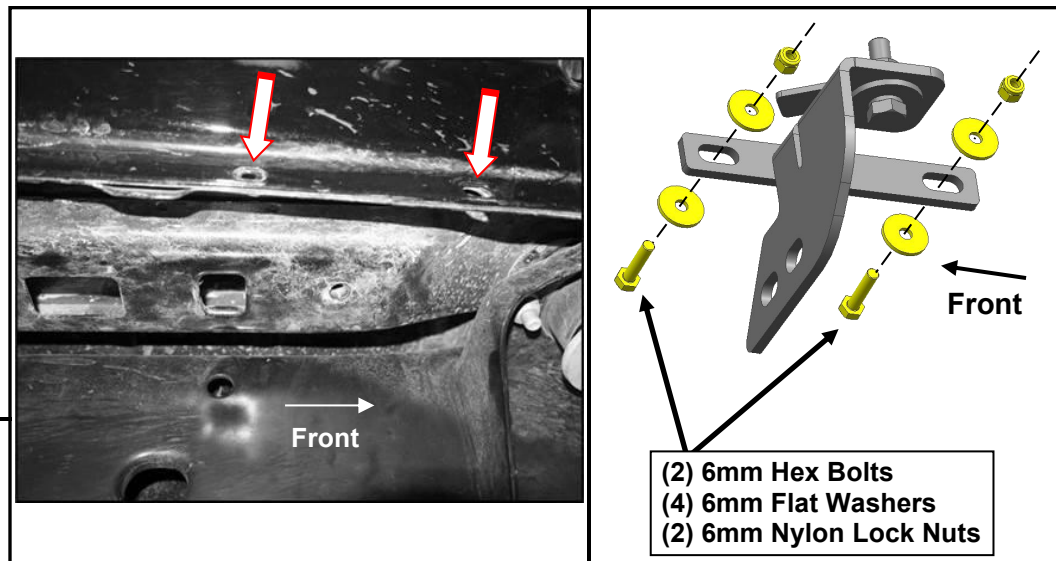
STEP 4

Loosely fit the Passenger Front step bracket to the **inside of the vehicle pinch weld** using (2) M6 x 25mm hex bolts, (4) M6 flat washers, and (2) M6 lock nuts. Do not fully tighten to allow for later adjustments. Repeat this step for all step brackets.

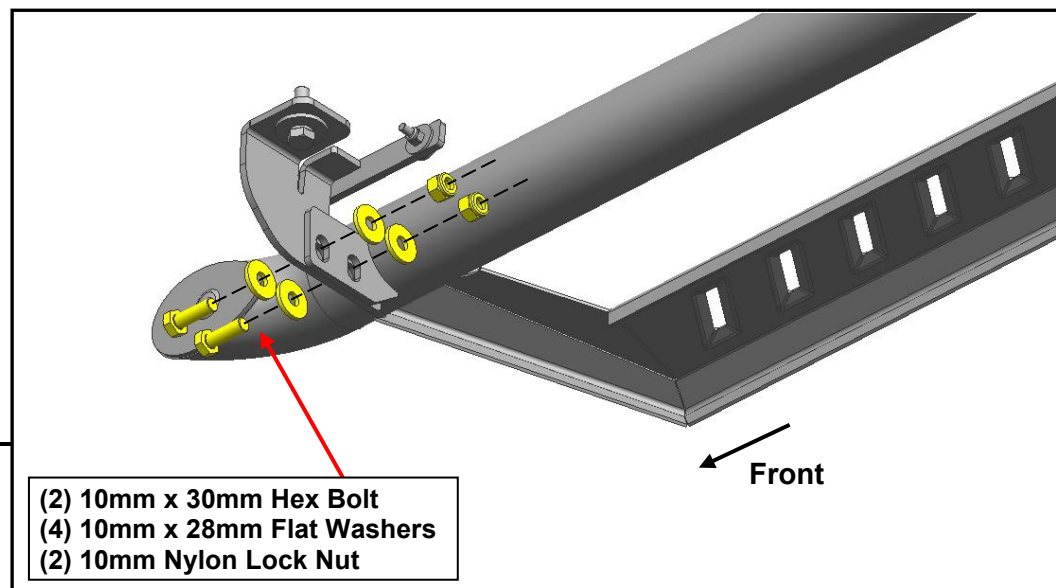
STEP 5

With all brackets loosely mounted to the vehicle, fit the running board to the brackets, and loosely secure into place using (2) M10 x 30mm hex bolts, (4) M10 x 28mm flat washers, and (2) M10 lock nuts.

Repeat this step for all step brackets.

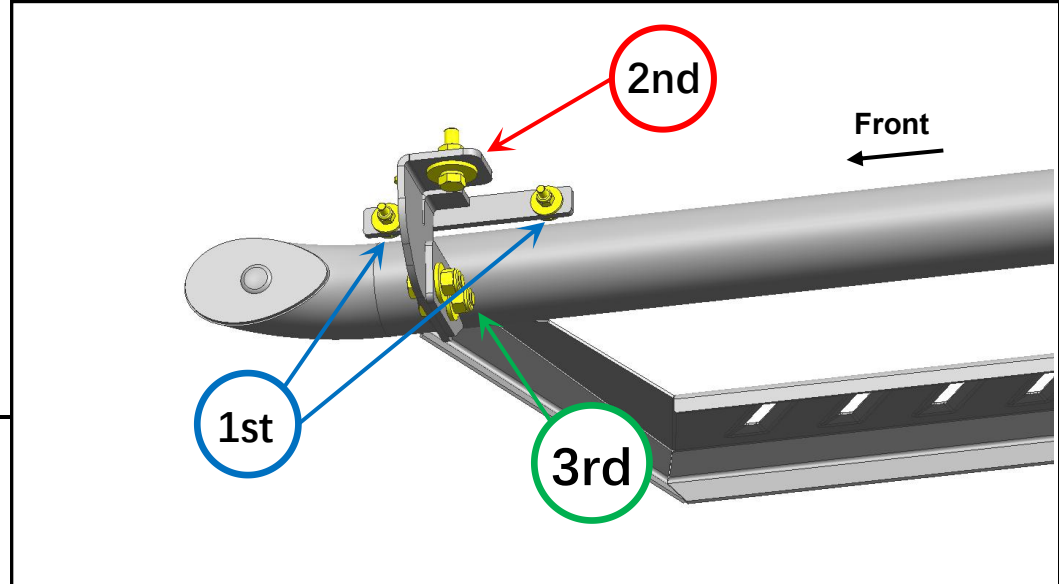
**STEP 6**

Tighten the mounting brackets to the vehicle (M6 first, then M8 / M10). Adjust the Running Board to the desired angle, and tighten the M10 × 30mm hex bolts, M10 × 28mm flat washers, and M10 lock nuts to secure the step into place. See photo for tightening order visual.

Repeat steps 1-6 for the remaining Running Board.

Installation is now complete.