

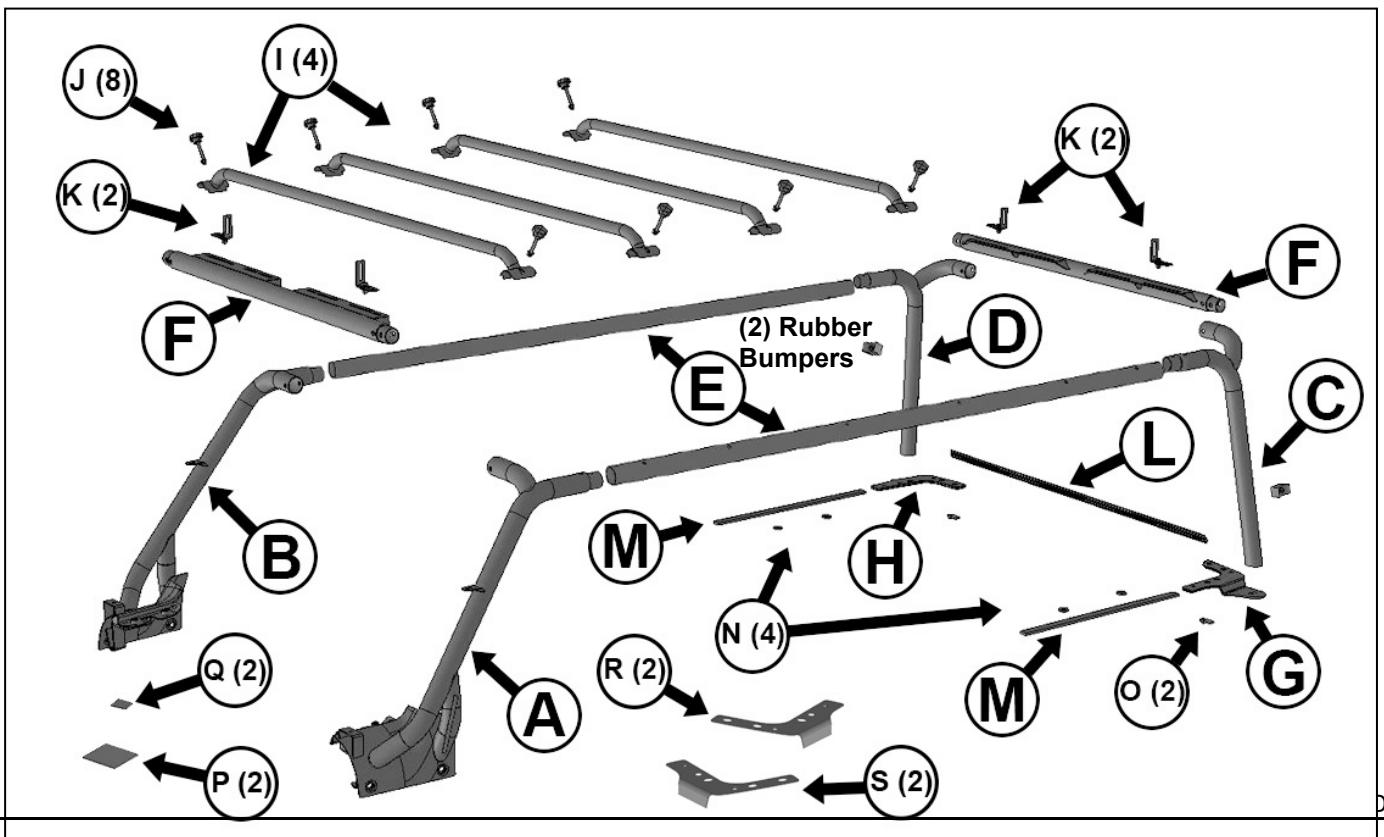

PARTS LIST: J138873-JL1 J138873-JL2

1	(A) Driver/Left Front Leg	5	12mm Wiring Grommets
1	(B) Passenger/Right Front Leg	4	(N) 12mm x 30mm x 5mm Spacer Washers
1	(C) Driver/Left Rear Leg	2	(O) 8mm Nut Plates
1	(D) Passenger/Right Rear Leg	8	10-1.50mm x 70mm Allen Bolts
2	(E) Left or Right Side Rails	2	10-1.50mm x 30mm Hex Bolts
2	(F) Front or Rear Cross Rails	2	10mm x 27mm x 3mm Flat Washer
1	(G) Driver/left Rear Mounting Bracket	16	10mm x 20mm x 2mm Flat washers
1	(H) Passenger/right Mounting Bracket	2	10mm Lock Washer
4	(I) Basket/accessory Crossbars	8	10mm Nylon Lock Nuts
8	(J) 8-1.25mm x 70mm Hex Bolt W-Knobs	6	8-1.25mm x 35mm Countersunk Lock Bolts
2	Rubber Bump Stops	4	8-1.25 x 25mm Hex Bolts
2	ST5-30 Self Tap Screws	24	8mm x 24mm x 2mm Large Flat Washers
2	ST 9.8mm x 5.4mm x 1.1mm Flat Washers	4	8mm Lock Washers
4	(K) "L" Light Brackets	4	8mm Hex Nuts
1	(L) Tailgate Top Seal	8	8mm Nylon Lock Nuts
2	(M) 650mm x 25mm x 8mm Foam Top Seals	1	6mm Wrench
1pr	1200mm x 10mm x .8mm 2-Sided Tape	1	5mm Wrench
2	(P) 80mm x 45mm x 2mm Front Foam Pads	1	150mm Foam Tube (antenna)
2	(Q) 36mm x 16mm x 2mm Front Foam Pads	1	Tube of Cleaner/Adhesive Activator
2	(S) Left Rear Mounting Bracket Foam Seals	1	Bottle-Thread Locking Compound
2	(R) Right Rear Mounting Bracket Foam Seals	20	Plastic Wire Ties
14	12mm Rubber Plugs		



PROCEDURE:

REMOVE CONTENTS FROM BOX. VERIFY ALL PARTS ARE PRESENT. READ INSTRUCTIONS CAREFULLY. ASSISTANCE IS REQUIRED.

1. Start installation by removing the roof panels and hard top assembly. **NOTE:** Follow the instructions provided in the owner's manual to remove the roof panels and top.
2. Remove both wiper arm assemblies, **(Figure 1)**. Next, carefully pry up sides of the plastic center trim panel to remove panel from top of cowl panel in front of windshield, **(Figures 1 & 2)**.
3. Open hood fully and rest hood on top of windshield. **IMPORTANT:** Place pad between hood and windshield to protect finish. Locate and remove the plastic clips under the rear rubber seal attaching the front of the cowl to the body, **(Figure 3)**. Lower hood and place hood on support prop.
4. Remove the bolts at both ends of the cowl, **(Figure 4)**. Carefully pry up the back of the plastic cowl panel to release the clips in the panel from the body. **NOTE:** The cowl does not have to be removed, only fully released to access windshield hinge hardware.
5. Remove the lower/outer bolts attaching the passenger/right side body corner panel and remove panel, **(Figure 4)**. Repeat to remove driver/left corner panel.
6. Remove the passenger/right outer hinge bolt, **(Figure 4)**.
7. Select the passenger/right front Roof Rack Leg, (1) Large and (1) Small Rectangular Foam Pads. Apply the Pads to the bottom of the Rack Leg Base, **(Figure 5)**.
8. With assistance, hold the Rack Leg up in place over the body. Line up the inner mounting hole in the Base with the windshield hinge. Reuse the factory hex bolt to attach the Base to the hinge, **(Figure 6)**. Reuse the factory bolts to attach the outer mounting holes in the Base to the threaded holes in the side of the body, **(Figure 7)**. Do not fully tighten hardware at this time.
9. Next, select the driver/left Rack Leg. Repeat **Steps 6—8** to install the Rack Leg.
10. Select (1) Cross Rail. Loosen Rack Legs enough to insert the Cross Rail between the top of the Rack Legs. Attach the Cross Rail to the Rack Legs with the included (2) 10mm x 70mm Button Head Bolts, (4) 10mm x 20mm Small Flat Washers and (2) 10mm Nylon Lock Nuts, **(Figure 8)**. Do not tighten hardware at this time. **NOTE:** It may be necessary or easier to temporarily remove one Rack Leg to insert the Cross Rail. Cross Rail can be installed with light tabs facing forward or to the rear.
11. Move to the passenger/right rear of the vehicle. Select the passenger/right Rear Mounting Bracket, (1) "Left" and (1) "Right" Adhesive Backed Foam Gaskets, **(Figure 9)**. Apply the Gaskets to the top and bottom of the Mounting Base.
12. Line up the (2) countersunk mounting holes in the Bracket with the factory threaded holes in the body, **(Figure 10)**. Apply included Thread Lock Compound to (3) 8mm Countersunk Bolts, **(Figure 11A)**. Attach the Bracket to the top of the body with (2) 8mm x 35mm Countersunk Bolts, **(Figure 11B)**. Next, select (1) 8mm Nut Plate. Push the plastic cover down slightly and insert the Nut Plate under the edge of the body. Attach the Bracket to the Nut Plate with (1) 8mm x 35mm Countersunk Bolt, **(Figure 11B & 12)**. Fully tighten the mounting hardware at this time.
13. Select (1) 25.5" x 1" (650mm x 25mm) Long Foam Seal, **(Figure 13)**. Remove the factory seal from the top of the body. Clean surface with isopropyl alcohol, (not included). Apply Foam Seal tight against Mounting Base and along body in same location as factory seal, **(Figure 14)**. Trim as required.
14. Repeat **Steps 11—13** to install the driver/left Mounting Bracket and Side Seal.
15. Reinstall hardtop and top panels if desired. **IMPORTANT:** before reinstalling top, place the included (4) 12mm x 30mm x 5mm Spacer Washers over the threaded holes in both sides of the body, **(Figure 13)**. Insert the factory bolts for top down through the top, the Spacer and into the body to support the top, **(Figures 13 & 15)**.

(EXCL. 21-24 4XE / MODELS WITH OE SOFT TOP & 4-DOOR TRIMS WITH SKY ONE-TOUCH POWER TOP)

16. Select (1) Side Rail. Attach the Side Rail to the back of the Front Leg with (1) 10mm x 70mm Button Head Bolt, (2) 10mm x 20mm Small Flat Washers and (1) 10mm Nylon Lock Nut, **(Figure 16)**. Make sure Side Rail is oriented properly. **IMPORTANT:** Do not let Side Rail damage the top. Do not tighten.
17. Next, select the passenger/right Rear Rack Leg, **(Figure 17)**. Repeat **Step 16** to attach the Rear Leg to the Side Rail. Attach the Rear Leg to the Mounting Bracket with (1) 10mm x 30mm Hex Bolt, (1) 10mm Lock Washer and (1) 10mm x 27mm Large Flat Washer, **(Figure 18)**. Leave hardware loose. Repeat this Step to attach the driver/left rear Rack Leg.
18. Select the remaining Cross Rail. Repeat **Step 10** to attach the Cross Rail to the rear Rack Legs with (2) 10mm x 70mm Button Head Bolts, (4) 10mm x 20mm Small Flat Washers and (2) 10mm Nylon Lock Nuts, **(Figure 19)**. Do not fully tighten. **NOTE:** Temporarily remove the driver/rear Rack Leg to attach the Cross Rail, then reattach the Rack leg, **(Figure 20)**.
19. With the Rack assembled, slide (1) Rubber Bumper between the top and the driver/left Rack Leg until the Bumper is just touching the side of the top, **(Figure 21)**. Move to the passenger/right side and slide the remaining Bumper between the Leg and the top. Adjust the height of the Bumpers an equal distance from the body and mark the location on the side of the tube facing the vehicle. Remove the driver/left Rear Leg. **NOTE**, it may be necessary to partially disassemble the rear section of the Rack to remove the Legs. Drill an 1/8" hole into the Rear Leg at the marked location, **(Figure 22)**. Drill only through the side requiring the Rubber Bumper. Do not drill through both sides of the tube. Attach the Rubber Bumper to the Rear Leg with (1) #5 x 30mm Screw and (1) 5mm Flat Washer, **(Figure 23)**. Snug but do not over tighten or the Rubber Bumper will be deformed. Once both Rubber Bumpers are installed, reassemble the Rack.
20. Move to the rear of the vehicle and open the tailgate. Clean the top edge (inside and outside) of the tailgate, **(Figure 24 - isopropyl alcohol recommended - not included)**. Select the small tube of adhesive Primer. Wipe the inside and outside of the tailgate with the Primer. Apply (1) strip of the Double Sided Tape to the outside of the tailgate close to but not over the top edge of the tailgate, **(Figure 25)**. Cut to fit width of tailgate. **IMPORTANT: DO NOT REMOVE the outer backing tape** from the Double Sided Tape at this time. Repeat to apply remaining Double Sided Tape to the inside of the tailgate.
21. Select the Rubber Edge Seal. Clean the channel in the Seal, **(Figure 26)**. Wipe the entire channel with Primer. Slide the Seal over the edge of the tailgate and the Double Sided Tape. Push the Seal down fully onto the tailgate. With the tailgate fully open, pull back the inner lip on the Seal with one hand, grab the end of (1) backing tape with the other hand and **slowly pull the backing tape off** to stick the Seal to the Tape, **(Figure 27A & 27B)**. Continue the full length of the Seal. Close the tailgate and repeat to attach the Seal to the Double Sided Tape on the outside of the tailgate, **(Figure 27A)**.
22. On models with antenna, slide the included Antenna Sleeve Tubing onto the antenna.
23. If bar style LED light will be installed, (not included), use brackets and hardware included with light or select (2) of the included "L" Light Bar Brackets, **(Figure 28)**. Attach the Brackets to the top of the Roof Rack with the included (2) 8mm x 25mm Hex Bolts, (4) 8mm Flat Washers, (2) 8mm Lock Washers and (2) 8mm Hex Nuts.
24. Next, select (1) Cargo Cross Bar, **(Figure 29)**. Attach the Crossbar to the top of the Side Rails with (2) 8mm x 70mm Bolts with integrated Knobs, (4) 8mm Flat Washers and (2) 8mm Nylon Lock Nuts, **(Figure 29)**. Repeat this Step to install the remaining (3) Cross Bars in desired locations. **NOTE:** (4) Cross Bars are included with the Roof Rack and can be installed in any of the (6) mounting locations depending on size and shape of roof basket (not included) or accessories, **(Figure 30)**.
25. Check the Roof Rack for alignment, adjust as necessary and fully tighten all hardware. Start tightening sequence at the base of the front Mounting Legs, then move to rear Mounting Bases, Rear and Front Cross Rails, both Side Rails and all Crossbars.
26. Reinstall front cowl, plastic trim panel and wiper arm assemblies.
27. Insert the included 12mm Rubber Plugs into any unused mounting holes. **NOTE:** (5) Rubber Grommets have been included for use to seal around any internal wiring, use as required.
28. Do periodic inspections to the installation to make sure that all hardware is secure and tight.

To protect your investment, Do not use any type of polish or wax that may contain abrasives that could damage the finish. Mild soap may be used to clean the Roof Rack.

Passenger/right Side Installation Pictured

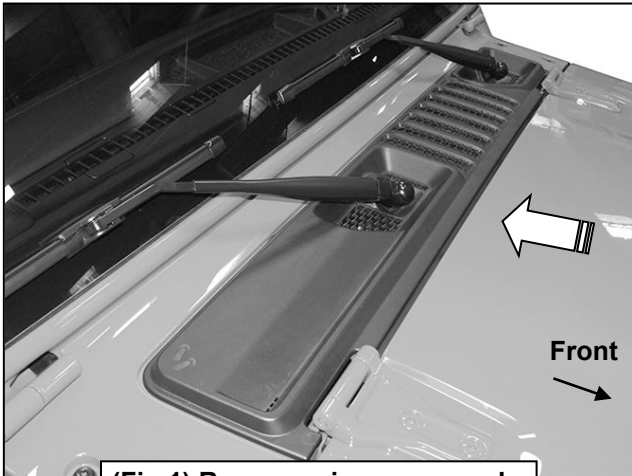

(Fig 1) Remove wiper arms and plastic cowl cover (arrow)

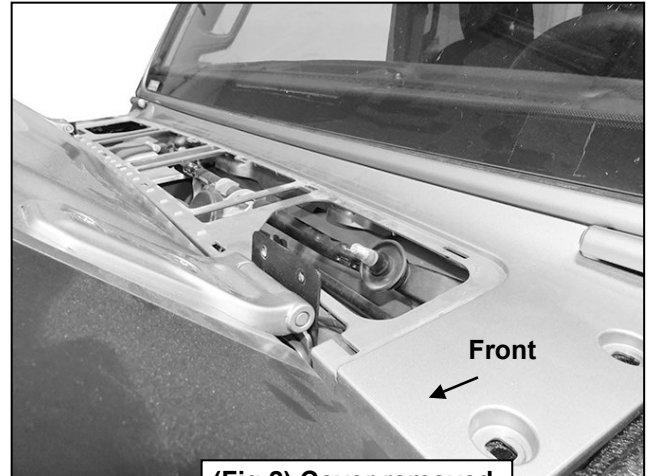

(Fig 2) Cover removed

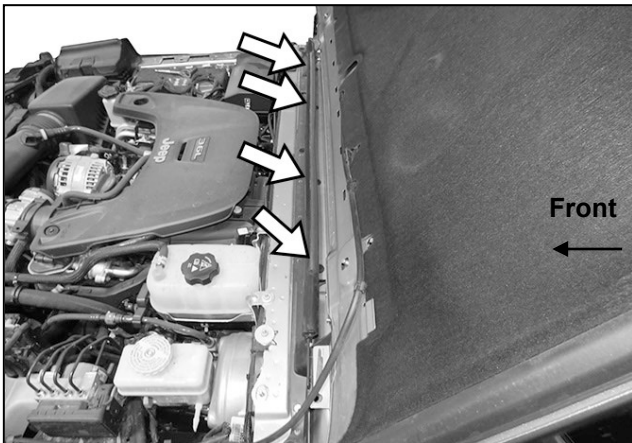

(Fig 3) Remove plastic clips behind rubber seal, attaching front of cowl to body (arrows)

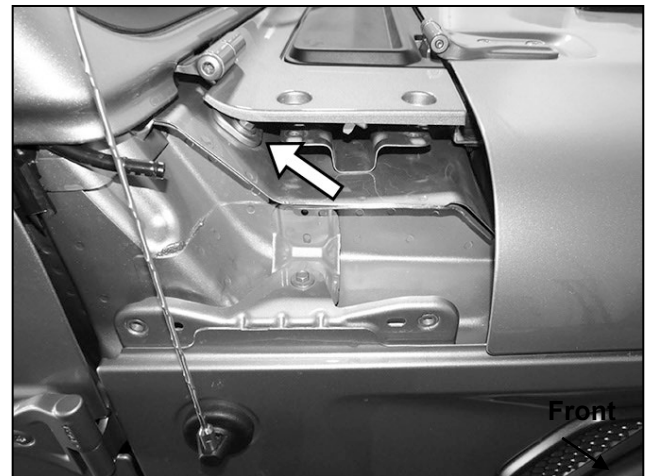

(Fig 4) Remove factory bolts to remove corner body panel. Remove outer bolt from windshield hinge (arrow)

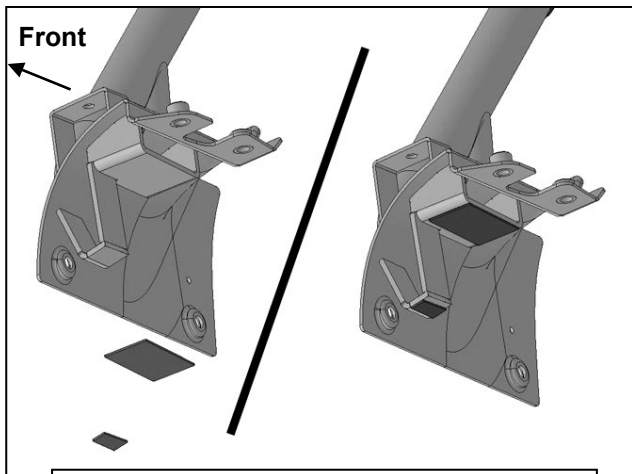

(Fig 5) Apply rectangular small and large Foam Pads to bottom of Front Rack Legs

Passenger/right Side Installation Pictured

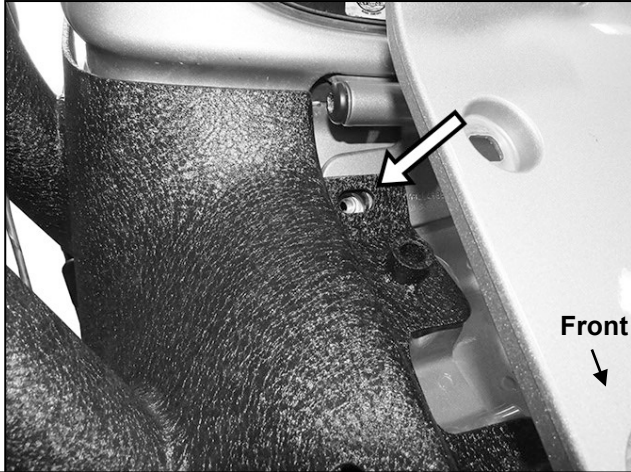

(Fig 6) Reuse factory bolt to attach passenger/right Front Rack Leg to top of windshield hinge

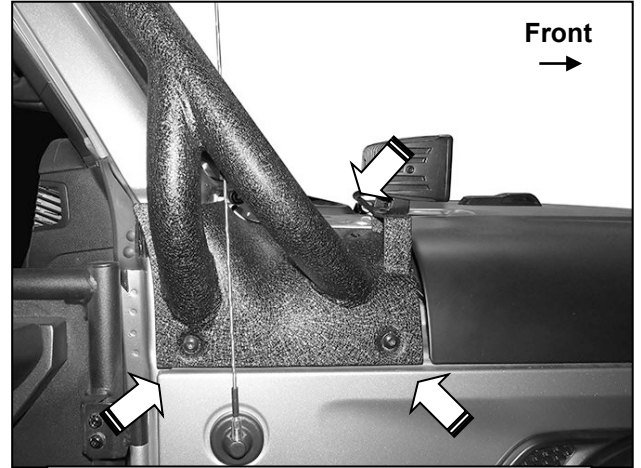

(Fig 7) Reuse factory bolts to attach passenger/right Front Rack Leg to body (arrows). Accessory light not included

10mm x 70mm Button Head Bolt
(2) 10mm x 20mm Flat Washers
10mm Nylon Lock Nut

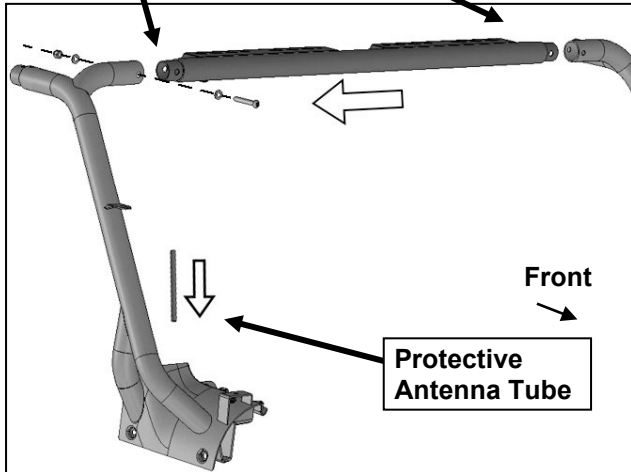

(Fig 8) Slide (1) Crossbar into the top of the installed passenger/right Front Rack Leg. Attach Crossbar to driver/left Rack Leg. NOTE: Crossbar can be installed with light tabs facing forward or to the back if desired

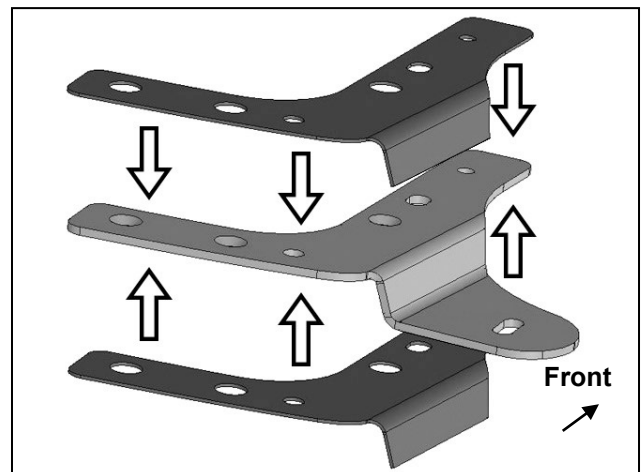

(Fig 9) Apply adhesive backed Foam Seals to the top and bottom of the passenger/right Rear Mounting Bracket before installing

Passenger/right Side Installation Pictured

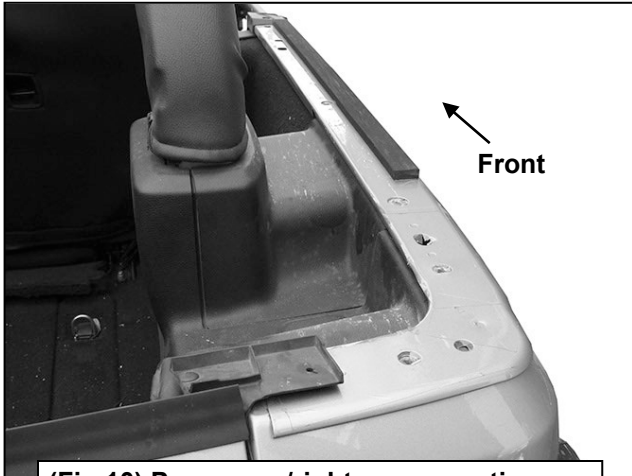

(Fig 10) Passenger/right rear mounting location. Remove factory side to top seal

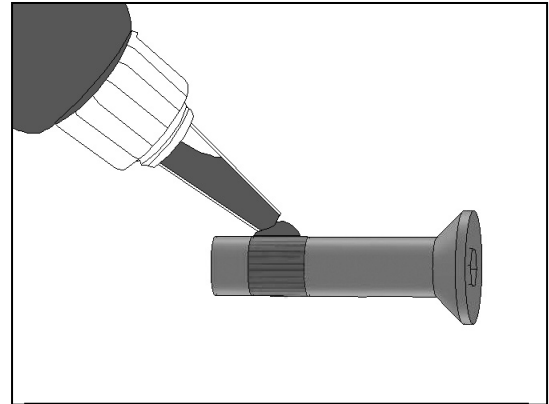

(Fig 11A) Apply included Thread Lock Compound to Countersunk Bolts

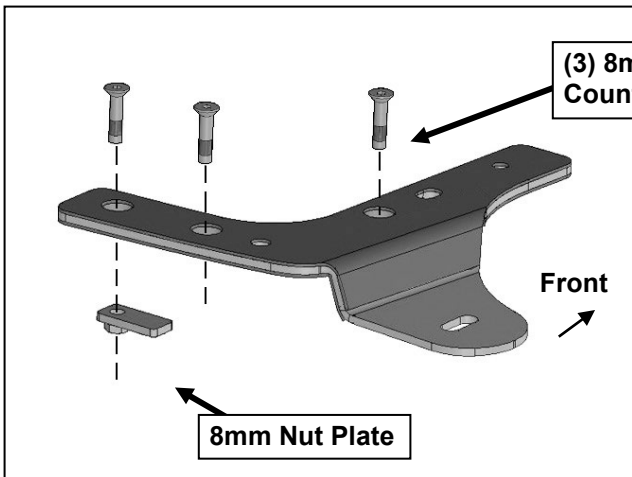

(3) 8mm x 35mm Countersunk Bolts

8mm Nut Plate

(Fig 11B) Attach Passenger/right Rear Mounting Bracket to top of body

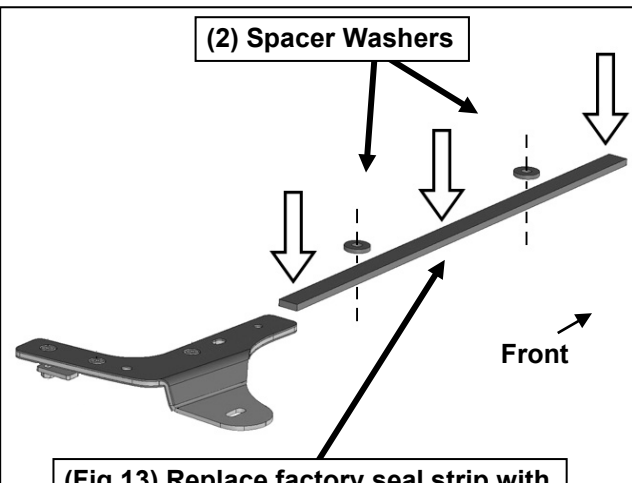

(2) Spacer Washers

(Fig 13) Replace factory seal strip with included thicker Top Seal (see Fig 14)



(Fig 12) Passenger/right Mounting Bracket installed

Passenger/right Side Installation Pictured



(Fig 14) Install Foam Seal in original location

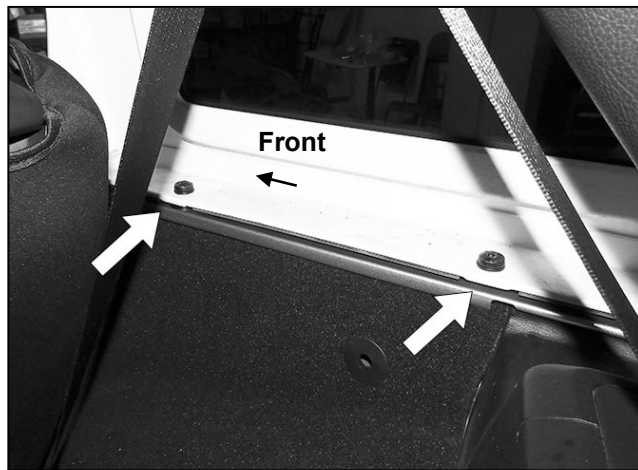

(Fig 15) Insert (2) Spacer Washers between top and body (arrows), over mounting holes (Fig 13)

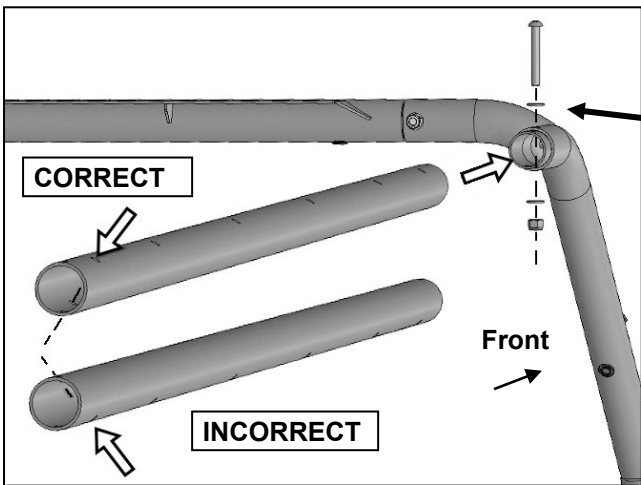

(Fig 16) Attach Sidebar to top of Front Rack Leg

10mm x 70mm Button Head Bolt
(2) 10mm x 20mm Flat Washers
10mm Nylon Lock Nut

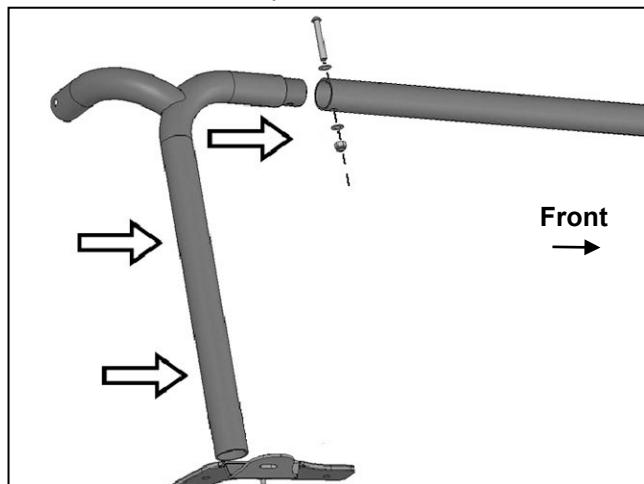

(Fig 17) Attach passenger/right Rear Leg to Sidebar

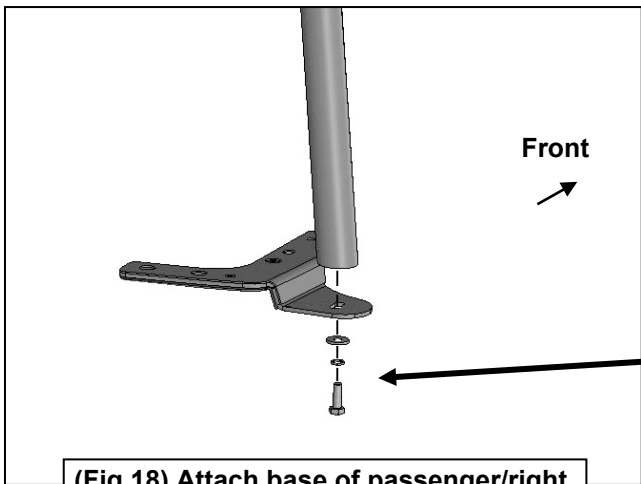

(Fig 18) Attach base of passenger/right Rear Leg to Mounting Bracket

10mm x 30mm Hex Bolt
10mm Lock Washer
10mm x 27mm Large Flat Washer

Passenger/right Side Installation Pictured

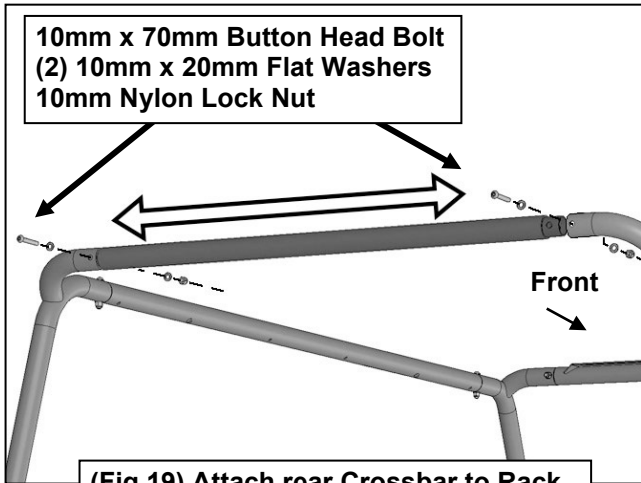

(Fig 19) Attach rear Crossbar to Rack Rear Legs (also see note Figure 9)

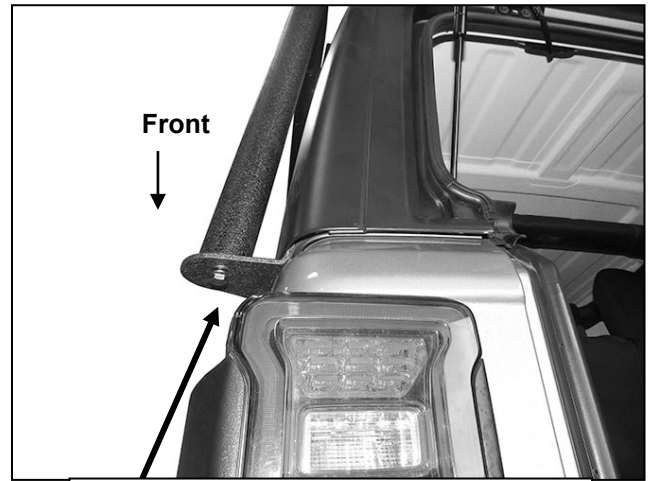

(Fig 20) Rear Leg attached to Mounting Bracket (driver/left side pictured)

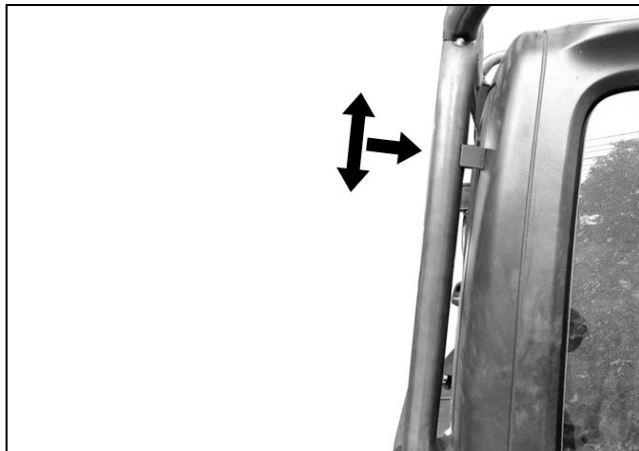

(Fig 21) Insert Bumpers evenly between Rear Legs and top (driver/left side pictured). Mark locations



(Fig 22) Drill 1/8" pilot hole

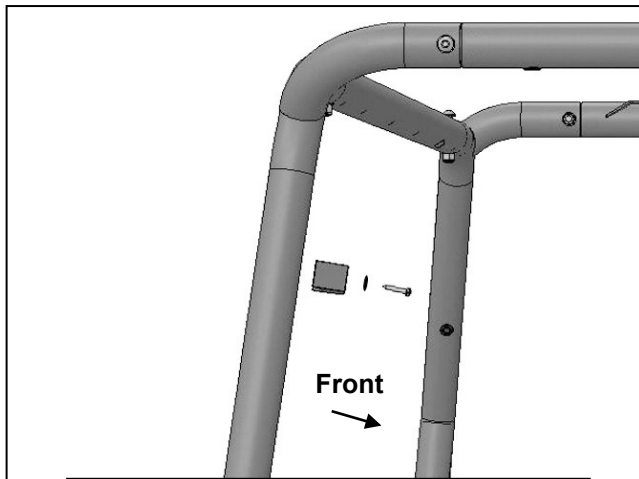

(Fig 23) Attach Bumpers with included #5 Screw and 5mm Flat Washer

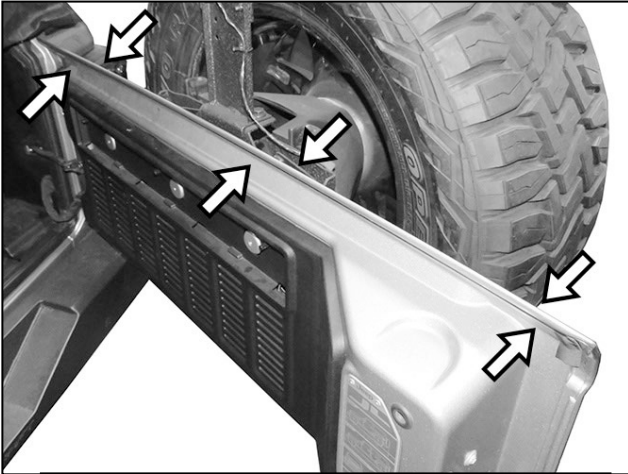

(Fig 24) Clean top of tailgate, inside and outside with included Adhesive Activator



(Fig 25) Apply (1) strip of Double Sided Tape to outside of tailgate, DO NOT REMOVE OUTER BACKING TAPE! Repeat to apply (1) strip of Tape to inside of tailgate

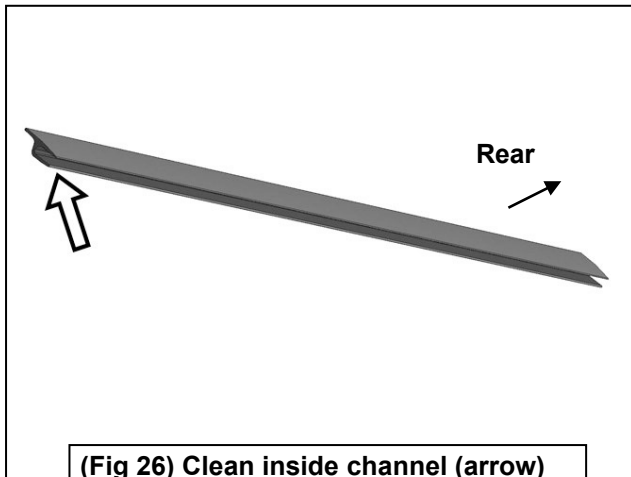

(Fig 26) Clean inside channel (arrow) on Tailgate Seal with Activator



(Fig 27A) Slide Seal over top of tailgate and Tape. Start at end, pull back outer lip on Seal to expose Tape. Slowly remove/pull off outer backing from Tape and stick Seal to Tape and tailgate. Repeat to remove backing from inner Tape on tailgate

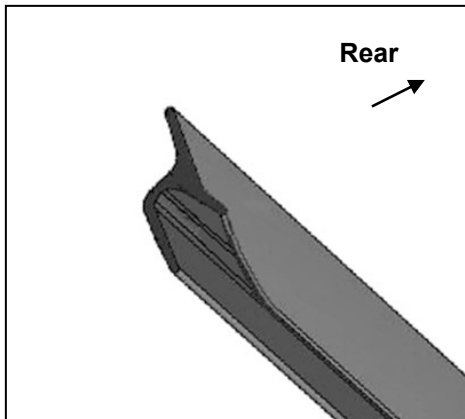

(Fig 27B) Pull back outer lip on Seal to expose Tape on tailgate (Fig 25)

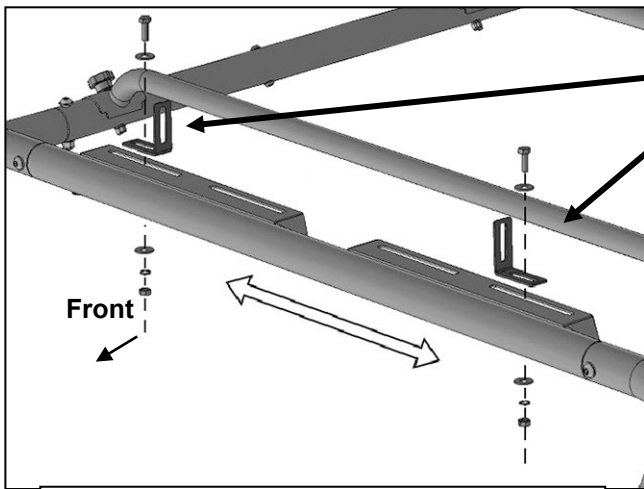

8mm x 25mm Hex Bolts
(2) 8mm Flat Washers
8mm Lock Washer
8mm Hex Nut

8mm x 70mm Bolt w/Knob
8mm Flat Washer
8mm Nylon Lock Nut

(Fig 28) Attach "L" Light Brackets to slots

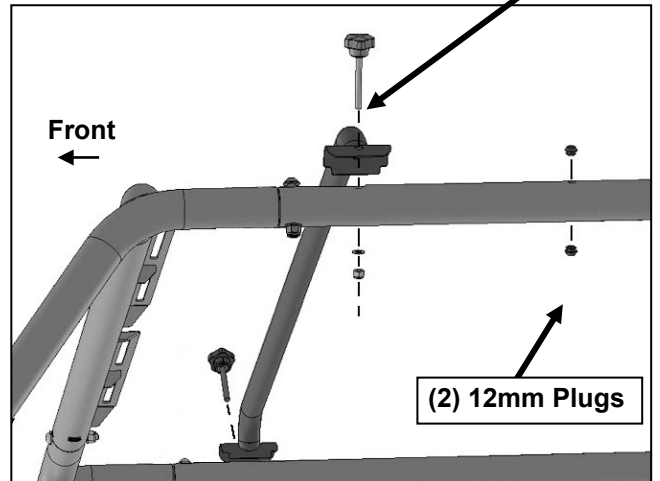

(Fig 29) Attach Cross Rails to top of Sidebars. Use Rubber Plugs to fill unused mounting holes in Side Rails

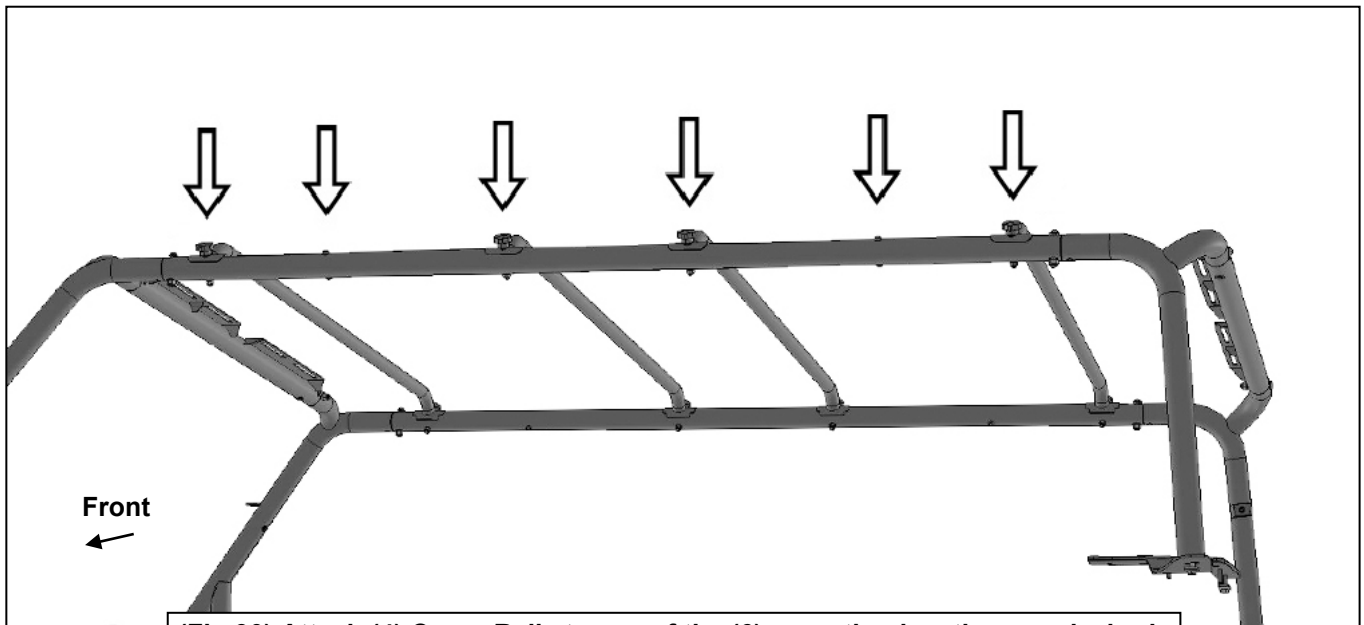

(Fig 30) Attach (4) Cross Rails to any of the (6) mounting locations as desired. Use 12mm Rubber Plugs to fill unused mounting holes in Side Rails