

PARTS LIST: J133202-JL J133203-JL

1	X-Series Rear Bumper	2	14-1.50mm x 55mm Fine Thread Hex Bolts
1	License Plate Bracket	2	14mm Lock Washers
2	LED License Plate Lights	2	14mm x 28mm x 3mm Flat Washers
4	Sensor Retaining Caps	2	8mm x 25mm Hex Bolts
4	20mm x 10mm Foam Spacers	4	8mm x 16mm x 1.6mm Flat Washers
4	15.5mm x 25mm x 2mm Foam Washers	2	8mm Nylon Lock Nuts
4	Sensor Hole Plugs	8	4mm Self Tapping Screws
1	Sensor Cover Kit	10	Wire Ties
1	14-1.50mm Fine Thread Double Nut Plate	1	4mm Wrench

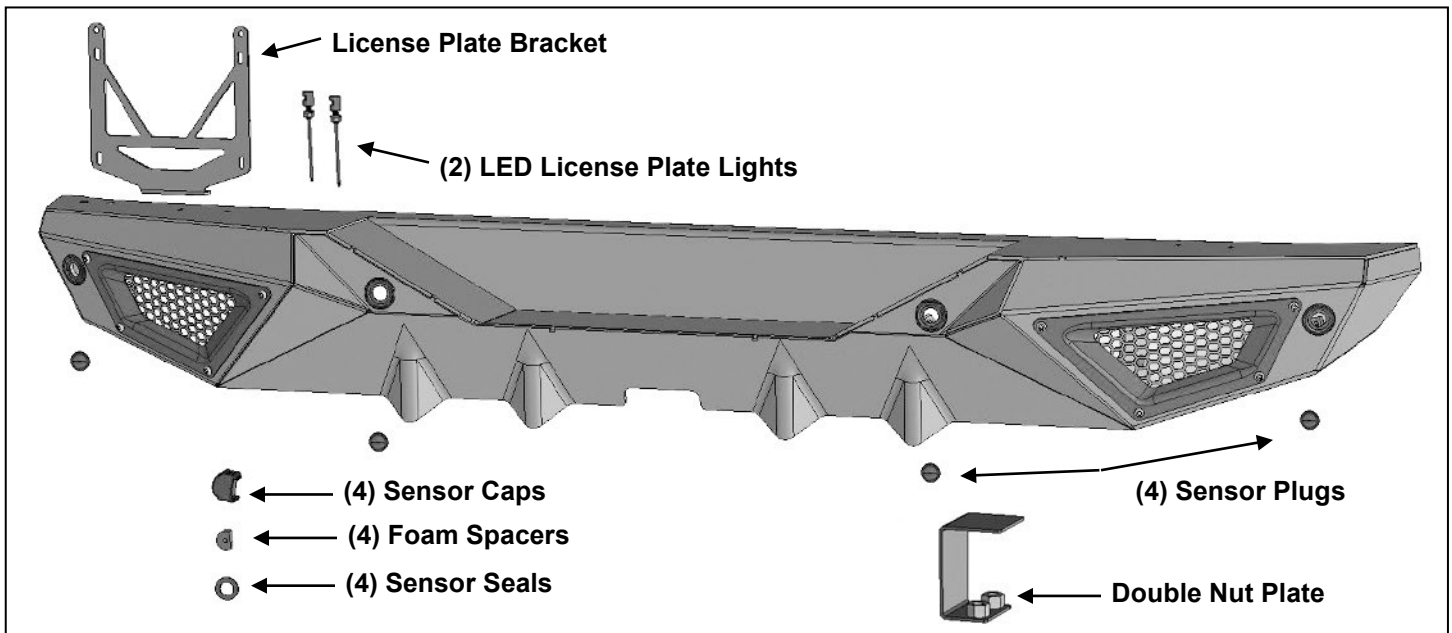

PROCEDURE:

REMOVE CONTENTS FROM BOX. VERIFY ALL PARTS ARE PRESENT. READ INSTRUCTIONS CAREFULLY BEFORE STARTING INSTALLATION. ASSISTANCE IS RECOMMENDED. WARNING: ALLOW TIME FOR THE MUFFLER TO COMPLETELY COOL BEFORE REMOVING REAR BUMPER.

1. Start installation from under the driver/left side of the rear bumper. Remove the plastic cover from the back of the rear wheel opening, **(Figure 1)**. Locate and remove the (2) hex bolts attaching the outer bracket running from the side of the frame to the outer end of the bumper, **(Figure 2)**. Remove the (2) hex bolts attaching the bottom of the bumper to the rear crossmember if equipped, **(Figure 3)**. Repeat this **Step** on the passenger/right side of the vehicle.
2. Unplug the wiring harness leading to the rear bumper.
3. With assistance, remove the (4) hex nuts attaching the bumper to the inner bumper brackets, **(Figure 4)**. Slide bumper off of the inner and outer bumper brackets.
4. Remove the driver/left outer bumper bracket attached to the side of the frame, **(Figure 4)**. Next, remove the (2) hex bolts attaching the tow hook to the side of the frame and remove the inner bumper bracket, **(Figure 5)**. **NOTE:** It may be necessary to loosen the (2) bolts attaching the tow hook to the bottom of the frame to remove bumper bracket. Do not remove tow hook.
5. Repeat **Step 4** to remove the Passenger/right side bumper brackets.
6. Insert the Double Nut Plate into the open end of the frame. Line up the Nut Plate with the holes in the bottom of the frame, **(Figure 6)**.

**X-SERIES REAR BUMPER
2018-ON JEEP WRANGLER JL ONLY**

7. Determine if the vehicle is equipped with bumper mounted parking sensors. **NOTE:** Depending on tow package, it may be necessary or easier to install sensors and harness before installing the Bumper.
Models without bumper sensors:
 - a. Push the included Plastic Plugs into sensor mounts, **(Figure 7)**.**Models with bumper mounted sensors:**
 - a. Disassemble the factory bumper to remove the wiring harness and sensors.
 - b. Select (1) sensor. Remove the seal from the end of the sensor. Slide the included Foam Sensor Seal Washer over front of the sensor, **(Figure 8)**.
 - c. Insert the sensor with Seal into the sensor mount, **(Figure 8)**.
 - d. Place (1) Foam Spacer over end of the sensor. Push Sensor Retaining Cap onto sensor mount and snap into mounting holes, **(Figure 8)**.
 - e. Repeat the previous Steps to install the remaining sensors.
 - f. Install wiring harness for sensors and plug harness into sensors.
8. With assistance, carefully position the Rear Bumper up to the outside of the frame. Attach the Bumper to the Nut Plate in the passenger/right frame end with the included (2) 14mm Fine Thread Hex Bolts, (2) 14mm Lock Washers and (2) 14mm Flat Washers, **(Figure 9)**. Reuse the factory hex bolts to attach the Bumper to the threaded inserts in the bottom and sides of the frame on both ends of the Bumper, **(Figures 10—12)**. Do not tighten hardware at this time.
9. Level and adjust the Rear Bumper and tighten all hardware.
10. Select the License Plate Bracket, **(Figure 13)**. Attach the Bracket to the top of the Bumper with the included (2) 8mm x 25mm Hex Bolts, (4) 8mm Flat Washers and (2) 8mm Nylon Lock Nuts.
11. Select the (2) LED License Plate Lights. Attach the Lights to the top (2) holes in the License Plate Bracket, **(Figure 13)**. Attach the wiring on the License Plate Lights to the wire harness for the factory license plate light.
12. On models with sensors, plug-in the bumper wiring harness to the main harness.
13. Do periodic inspections to the installation to make sure that all hardware is secure and tight.

To protect your investment, Do not use any type of polish or wax that may contain abrasives that could damage the finish. Mild soap may be used to clean Bumper.

Driver/left Side Installation Pictured

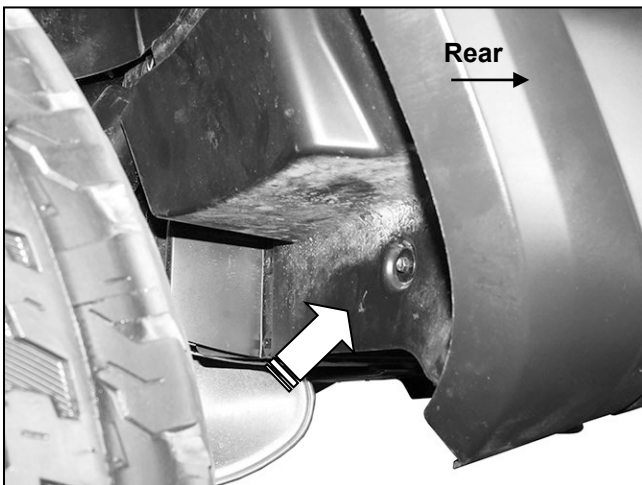

(Fig 1) Remove plastic cover (see arrow-driver/left side pictured)

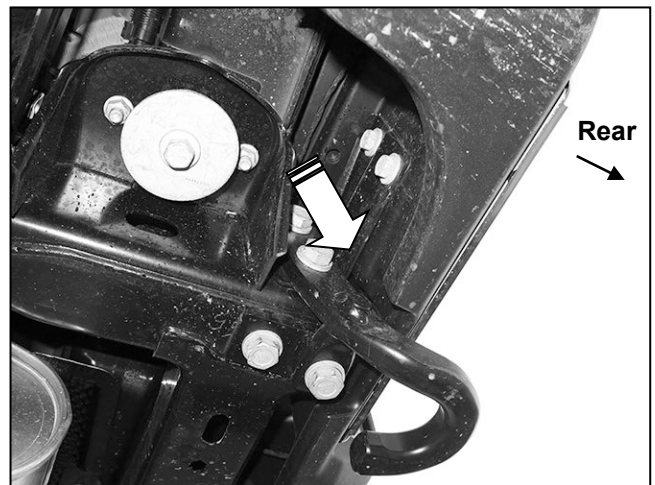

(Fig 2) Remove (2) outer bumper bracket bolts

Driver/left Side Installation Pictured



(Fig 3) Remove (2) hex bolts attaching bottom of bumper to frame cross member

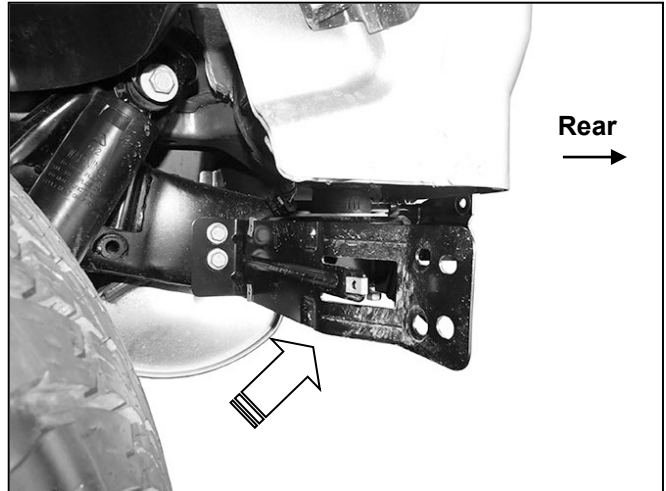

(Fig 4) Remove outer bumper bracket from side of frame

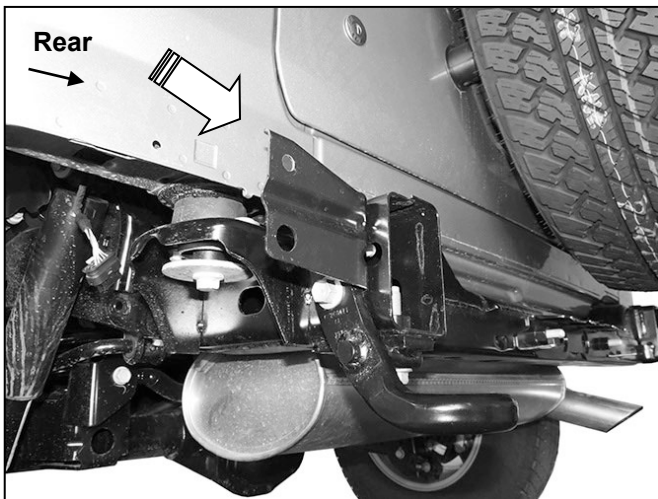

(Fig 5) Remove tow hook and inner bumper bracket from side of frame

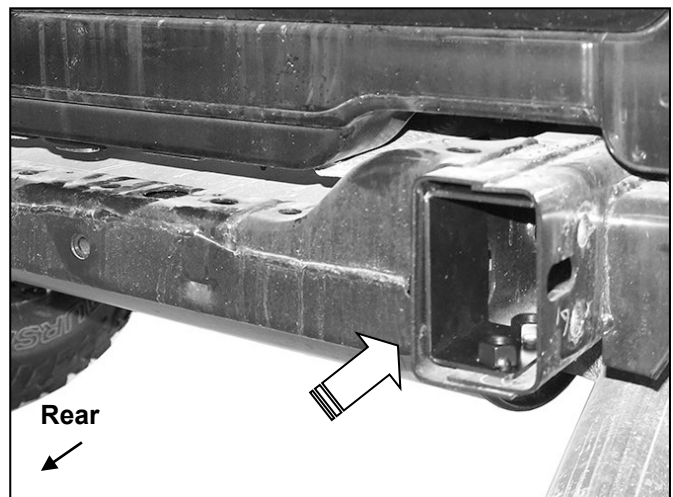

(Fig 6) Insert Double Nut Plate (arrow) into passenger/right end of frame

Driver/left Side Installation Pictured

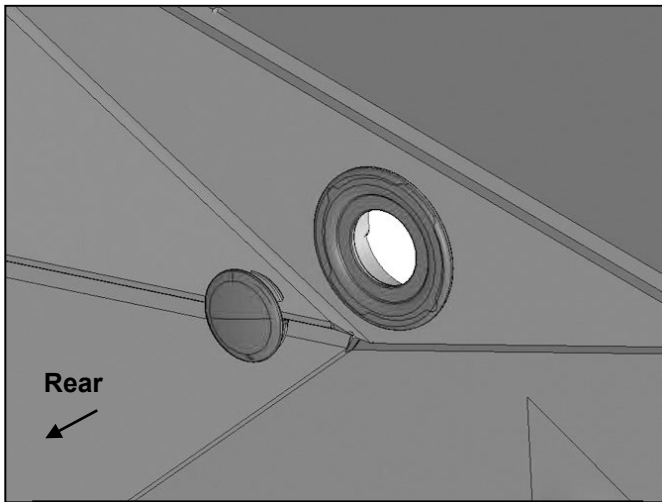

(Fig 7) Push Plastic Plugs into sensor mounts

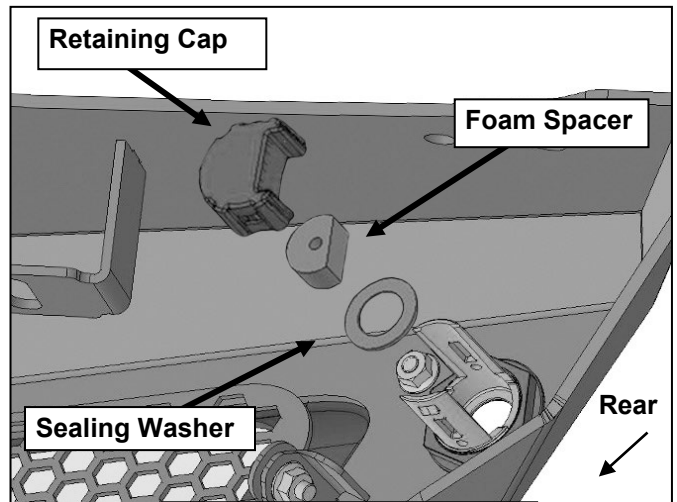

(Fig 8) Push sensor with Sealing Washer into mount

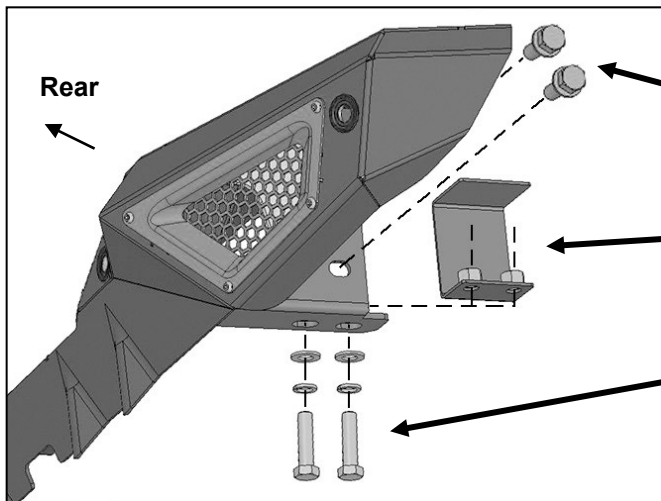

Reuse (2) factory bolts

Double Nut Plate

(2) 14mm Hex Bolts
(2) 14mm Lock Washers
(2) 14mm Flat Washers

(Fig 9) Attach passenger/right side of Bumper to Double Nut Plate. Reuse (2) factory hex bolts to attach Bumper to side of frame (see Fig 10)

**X-SERIES REAR BUMPER
2018-ON JEEP WRANGLER JL ONLY**

Driver/left Side Installation Pictured

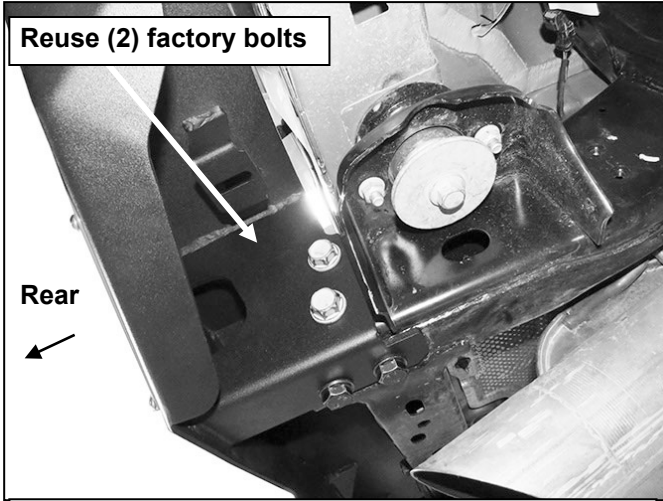

Reuse (2) factory bolts

Rear

(Fig 10) Passenger/right side of Bumper installed

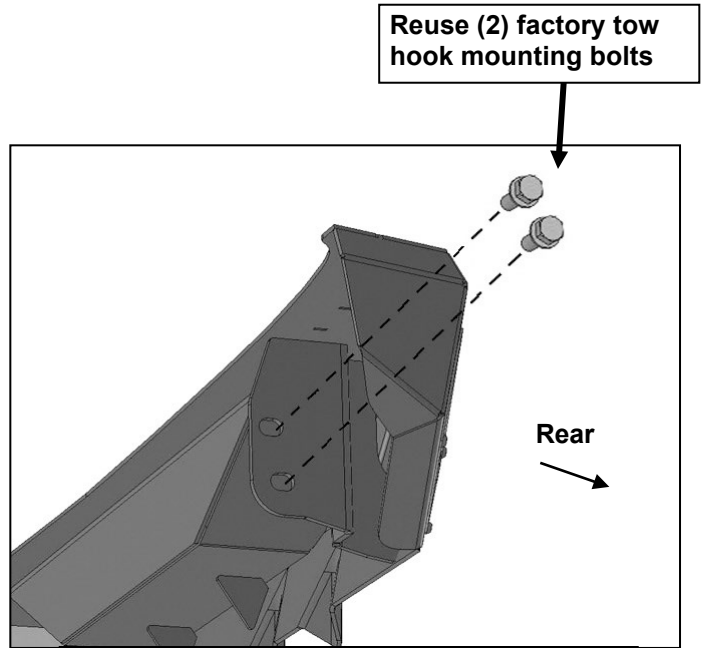

Reuse (2) factory tow hook mounting bolts

Rear

(Fig 11) Driver/left side of Bumper installed

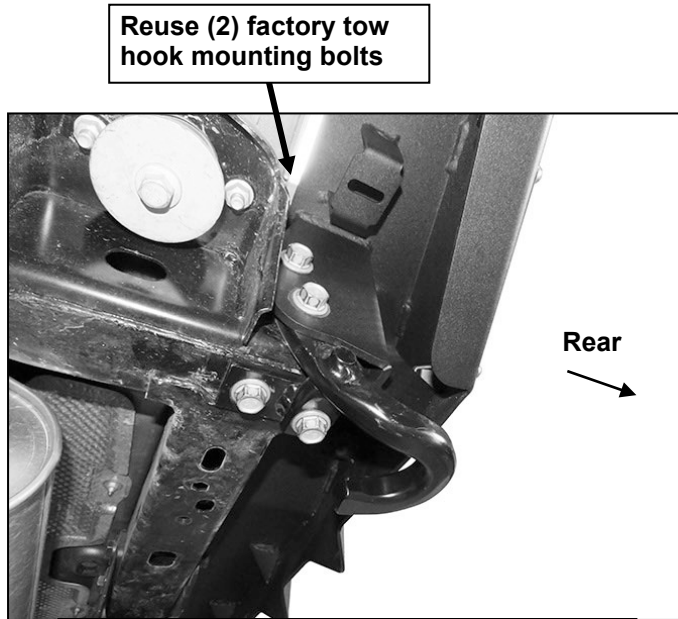

Reuse (2) factory tow hook mounting bolts

Rear

(Fig 12) Driver/left side of Bumper installed

- (2) 8mm x 25mm Hex Bolts
- (4) 8mm Flat Washers
- (2) 8mm Nylon Lock Nuts

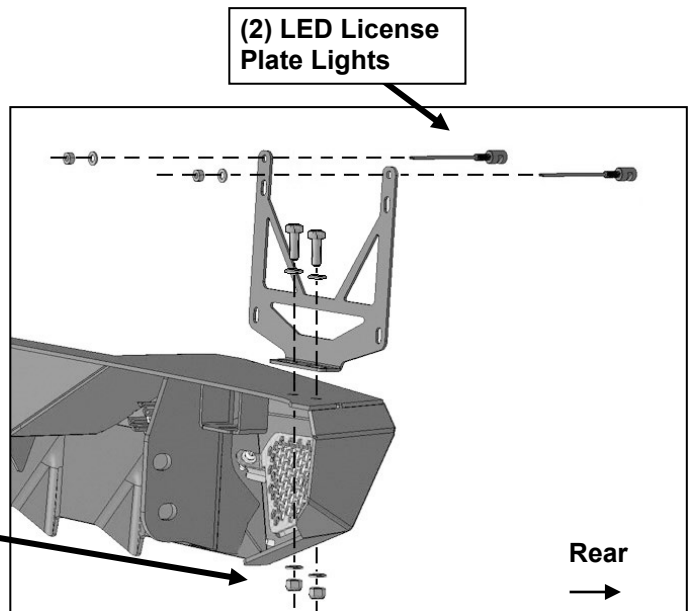

(2) LED License Plate Lights

Rear

(Fig 13) Attach License Plate Bracket to the top of the driver/left side of the Bumper