

REDROCK

INSTALLATION INSTRUCTIONS

SIDE ARMOR

2007-2018 WRANGLER JK 4 DOOR

SKU # J131130

PARTS LIST:

1	Driver/Left Side Armor Assembly	6	8-1.25mm x 35mm Hex Bolts
1	Passenger/Right Side Armor Assembly	6	8mm Lock Washers
6	10mm Nut Plates	6	8mm x 28mm OD x 3mm Large Flat Washers
6	10-1.5mm x 35mm Hex Bolts	12	6-1.0mm x 25mm Hex Head Bolts
6	10mm Lock Washers	24	6mm ID x 22mm OD x 2mm Flat Washers
6	10mm x 34mm OD x 3mm Flat Washers	12	6mm Nylon Lock Nuts

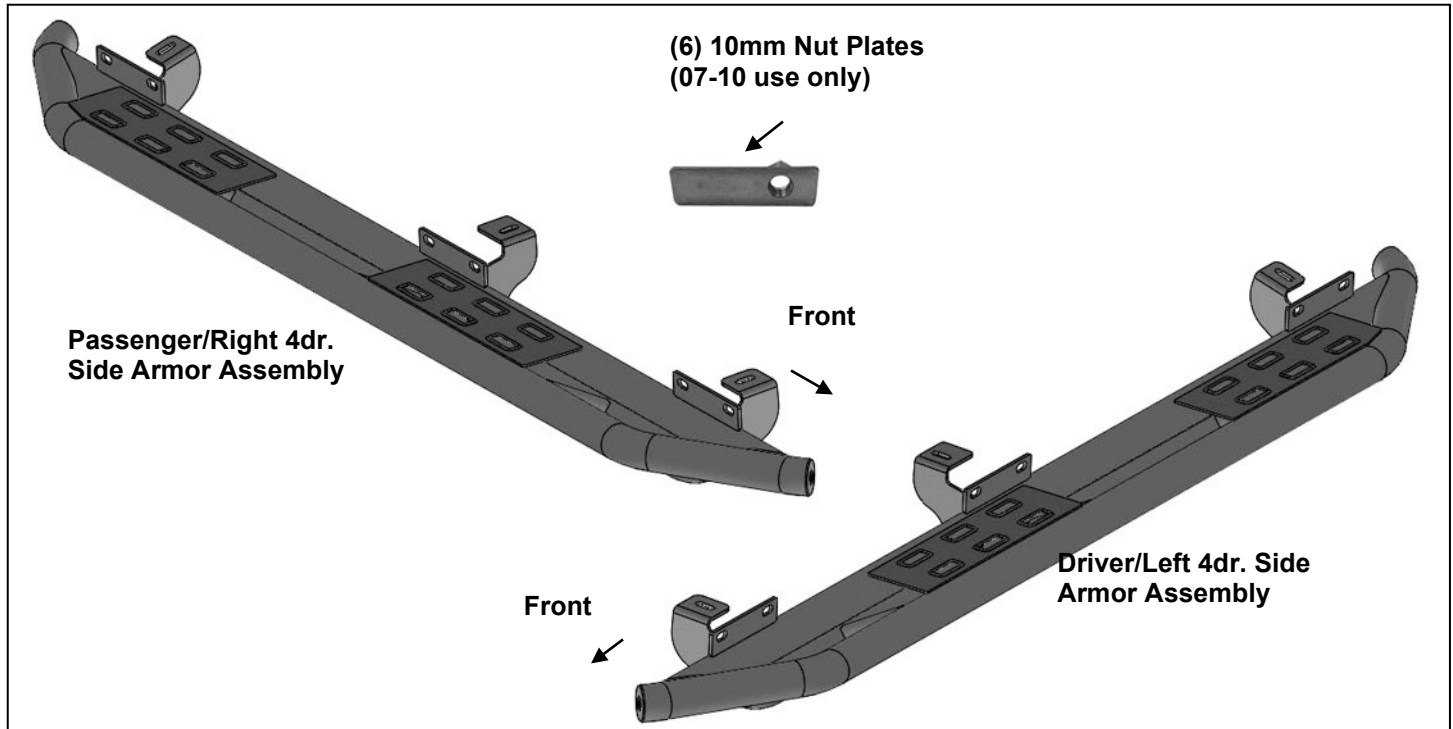

PROCEDURE: REMOVE CONTENTS FROM BOX. VERIFY ALL PARTS ARE PRESENT. READ INSTRUCTIONS CAREFULLY. FACTORY INSTALLED OR AFTERMARKET "ROCK RAILS," SIDE STEPS OR RUNNING BOARDS MUST BE REMOVED. ASSISTANCE IS HIGHLY RECOMMENDED.

1. Start installation on the passenger side of the vehicle. Locate the (3) factory pairs of mounting holes along the pinch weld, **(Figure 5)**. The mounting brackets on the Side Armor attach to the holes in the pinch weld and the small hole directly behind the pinch weld.
2. Determine if the vehicle has an open floor panel, **(2007-10, Figure 1)**, or threaded holes in the floor panel, **(2010-15, Figure 2)**, for the top tab on the Bracket.

Vehicles with open mounting locations along floor panel:

- a. Move to the front pair of holes in the pinch weld. Locate the mid-point between the two holes, **(Figure 3)**. Insert (1) 10mm Nut Plate into the large square opening in the floor panel, **(Figures 4A & 4B)**. Line up the threaded nut with the small hole directly in line with the mid-point, **(Figure 3)**.
- b. Repeat to install the 10mm Nut Plate as required in any/all locations.

Vehicles with factory threaded holes in floor panel: Skip to Step 4.

3. With assistance, hold the passenger Side Armor up in place against the back of the pinch weld. Line up the (3) brackets with the (6) factory holes in the pinch weld. Bolt the brackets to the **back** of the pinch weld with the included (6) 6mm x 25mm Hex Bolts, (12) 6mm Flat Washers and (6) 6mm Nylon Lock Nuts, **(Figures 5 & 6)**. Leave hardware loose at this time.
4. Bolt each top tab on the Side Armor to the vehicle:
 - a. Models with "open floor" requiring 10mm Nut Plate, attach each bracket to the Nut Plate with (1) 10mm x 35mm Hex Bolt, (1) 10mm Lock Washer and (1) 10mm Flat Washer, **(Figures 4B, 6 & 7)**. Repeat for any/all mounting locations.
 - b. Models with 8mm threaded factory holes, attach each bracket with (1) 8mm x 35mm Hex Bolt, (1) 8mm Lock Washer and (1) 8mm Flat Washer, **(Figures 2, 6 & 7)**. Repeat for any/all locations.
5. Level and adjust the Side Armor and tighten all hardware.

6. Repeat **Steps 2—6** for driver Side Armor installation.
7. Do periodic inspections to the installation to make sure that all hardware is secure and tight.

To protect your investment: Wax this product after installing. Regular waxing is recommended to add a protective layer over the finish. Do not use any type of polish or wax that may contain abrasives that could damage the finish. Mild soap may be used to clean the Side Armor.

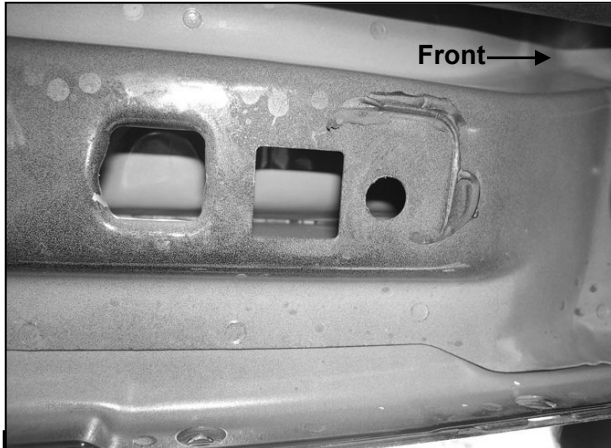

(Fig 1) 2007-10 driver side front mounting location

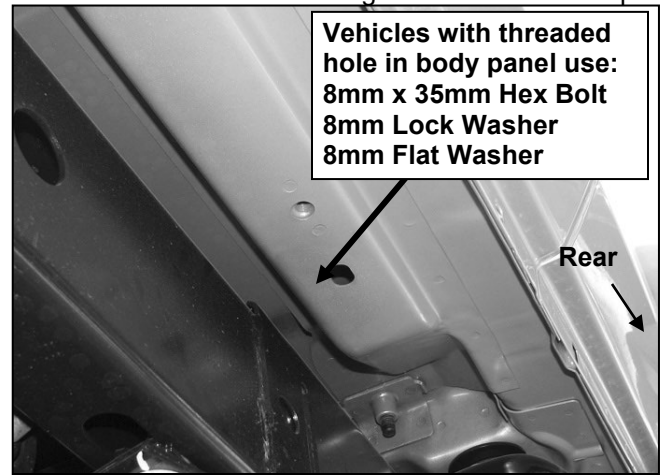

(Fig 2) Example of 2010-15 "closed" floor panel with 8mm threaded hole-10mm Nut Plate not required

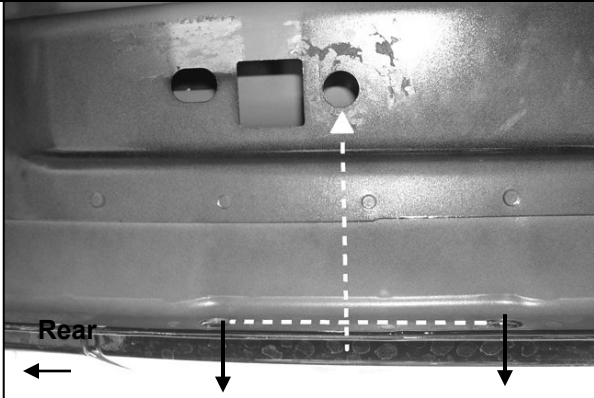

(Fig 3) 2007-10 driver side rear mounting location pictured from below. Locate the holes in the pinch weld first to determine correct mounting hole for 10mm Nut Plate

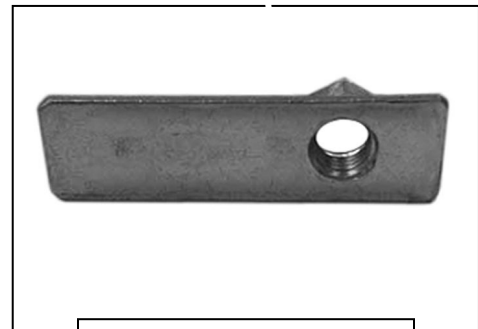

(Fig 4A) 10mm Nut Plate

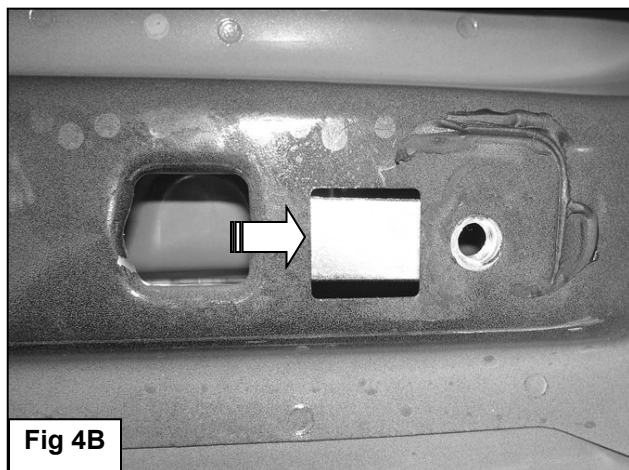

Fig 4B

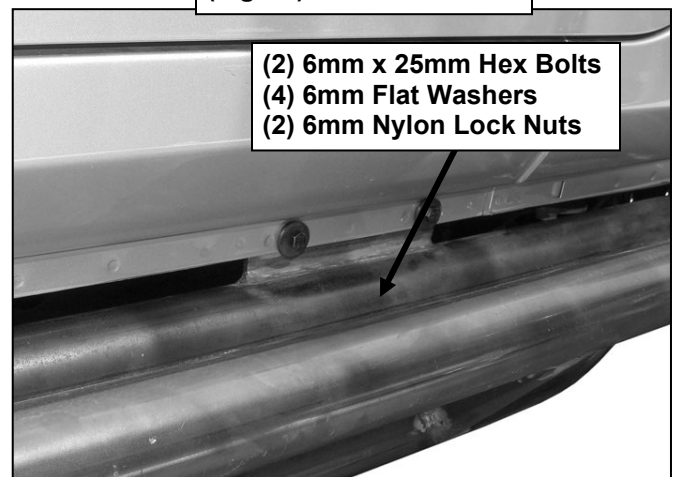
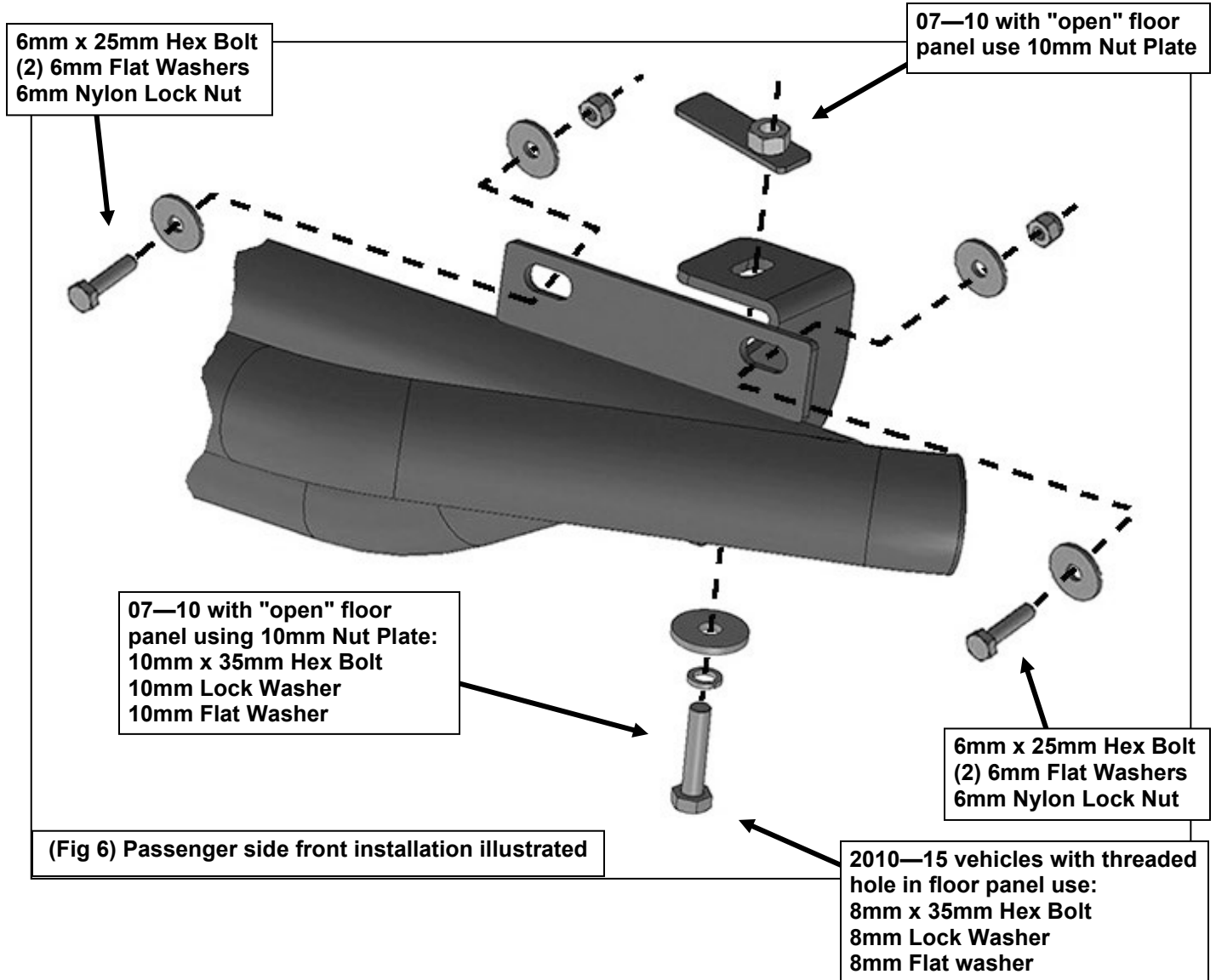

Fig 5



(Fig 7) Passenger rear installation pictured

