

# **REDROCK**<sup>4X4</sup>

## **INSTALLATION INSTRUCTIONS**

**FRONT TUBULAR BUMPER**

**07-17 WRANGLER JK/ 2018 WRANGLER JL**

**PARTS LIST:**

1	Front Tube Bumper	8	12-1.75mm Nylon Lock Nuts
2	L-Shaped Mounting Brackets	2	6mm Button Head Combo Bolts
8	12-1.75mm x 35mm Hex Bolts	1	4mm Allen Wrench
16	12mm x 37mm x 3mm Large Flat Washers		

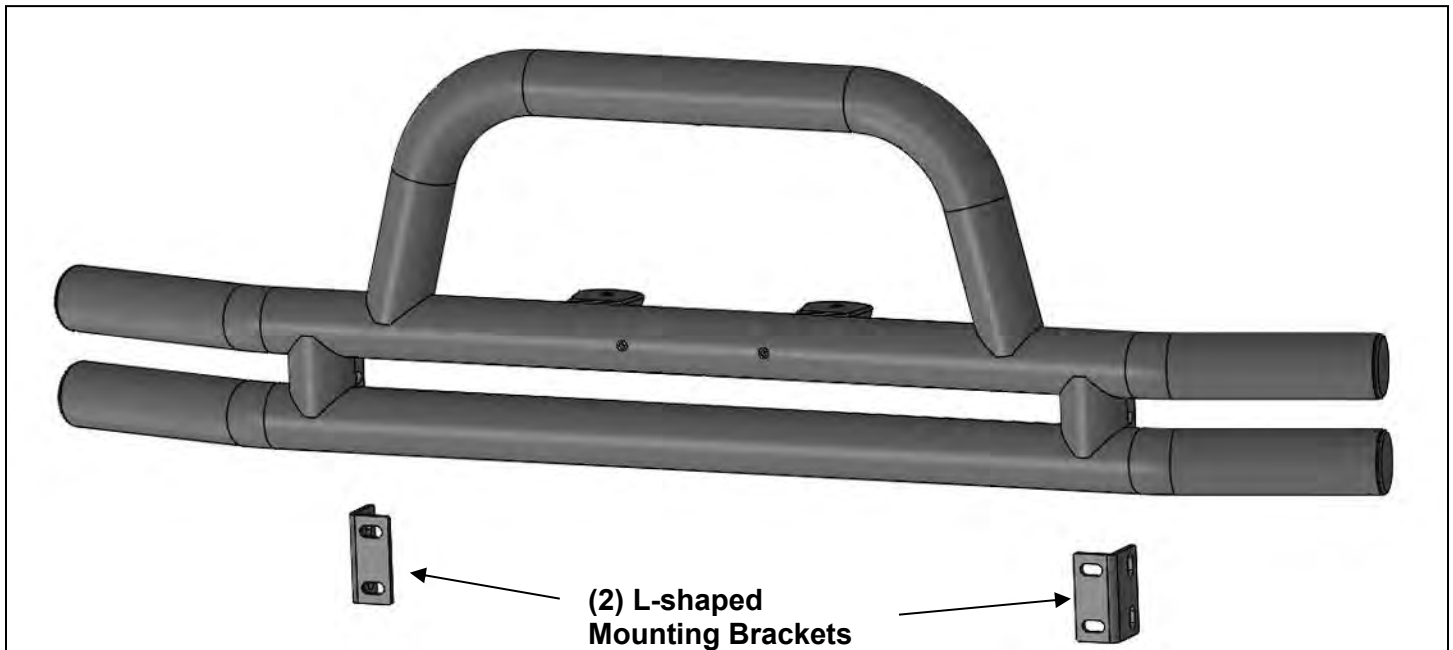

**PROCEDURE:**

**REMOVE CONTENTS FROM BOX. VERIFY ALL PARTS ARE PRESENT. READ INSTRUCTIONS CAREFULLY BEFORE STARTING INSTALLATION. CUTTING MAY BE REQUIRED. ASSISTANCE IS RECOMMENDED. FACTORY FOG LIGHT ASSEMBLIES AND/OR OE STEEL WINCH BUMPER CANNOT BE INSTALLED.**

1. Start under the front bumper of the vehicle and remove the plastic lower splash guard or skid plate, **(Figure 1)**.
2. On models with factory fog lights, unplug wiring harness leading to the bumper before removing bumper. **NOTE:** Fog lights cannot be reinstalled.
3. With assistance, remove the front bumper hardware and bumper, **(Figures 2—4)**. Move the factory bumper to a stable surface.
4. Select (1) Mounting Bracket, **(Figure 5)**. Use (2) 12mm Hex Bolts, (4) 12mm Flat Washers and (2) 12mm Nylon Lock Nuts to attach the Mounting Bracket to the outer factory frame bracket on the driver/left side of the frame, **(Figure 6)**. Leave hardware loose at this time.
5. Repeat **Step 4** to attach the remaining Mounting Bracket on the passenger/right side of the frame.
6. With assistance, align the mounting tabs on the Front Tube Bumper to the outside of the Mounting Brackets. Use (4) 12mm Hex Bolts, (8) 12mm Flat Washers and (4) 12mm Nylon Lock Nuts to attach the mounting tabs on the Bumper to the Mounting Brackets, **(Figures 7 & 8)**. Do not fully tighten hardware at this time.
7. Stand back from the vehicle and check to see that the Bumper is centered and level on the vehicle and adjust as required. Once properly aligned, fully tighten all hardware.

8. Use the provided (2) 6mm Button Head Combo Bolts to attach the License Plate to the front of the Tube Bumper.
9. Do periodic inspections of the installation to make sure that all hardware is secure and tight.  
**To protect your investment**, wax this product after installing. Regular waxing is recommended to add a protective layer over the finish. Do not use any type of polish or wax that may contain abrasives that could damage the finish. Mild soap may be used to clean the Front Bumper.

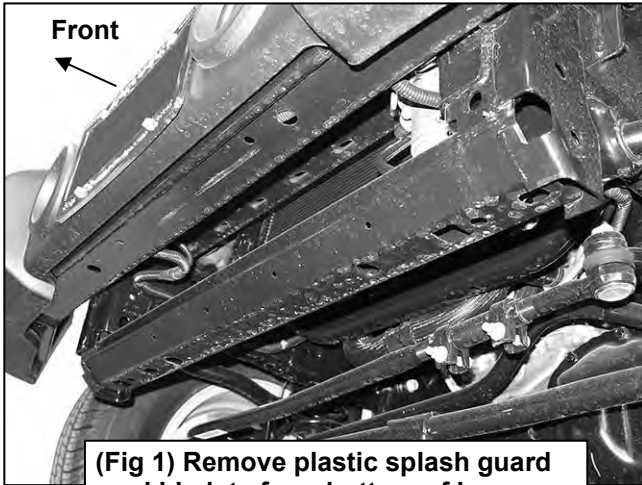

(Fig 1) Remove plastic splash guard or skid plate from bottom of bumper

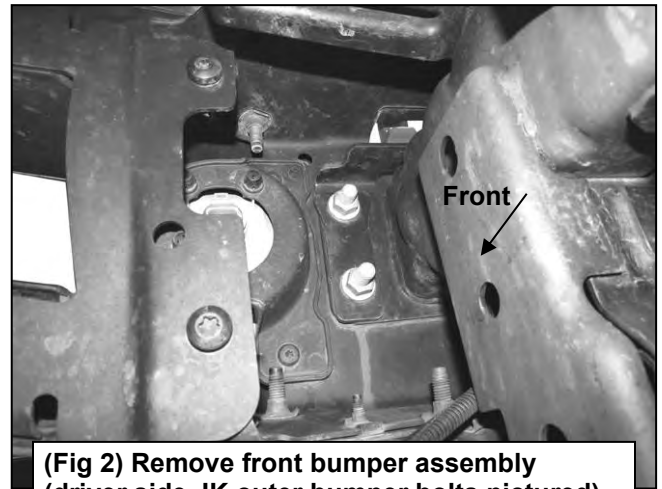

(Fig 2) Remove front bumper assembly (driver side JK outer bumper bolts pictured)



(Fig 3) Front Bumper and splash guard removed from 2007-18 JK model pictured



(Fig 4) Front Bumper and splash guard removed from 2018-on JL model pictured

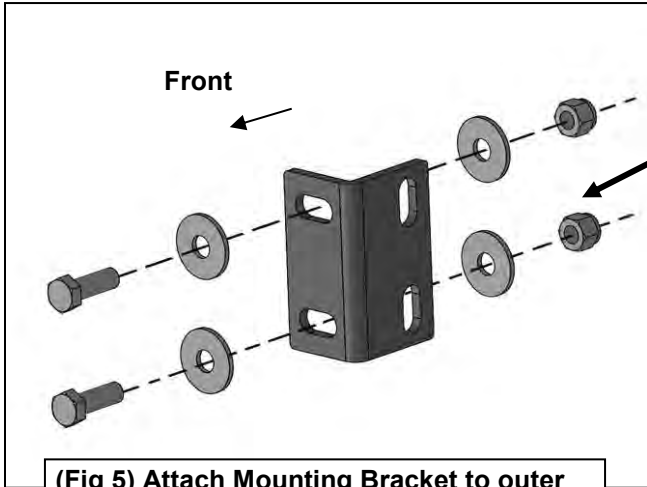

- (2) 12mm Hex Bolts
- (4) 12mm Flat Washers
- (2) 12mm Nylon Lock Nuts

(Fig 5) Attach Mounting Bracket to outer side of the driver/left side Frame Bracket

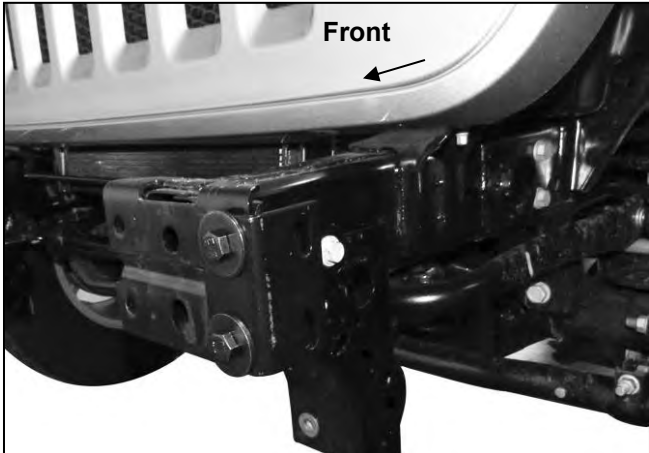

(Fig 6) Attach Mounting Bracket to outer side of the driver/left side Frame Bracket

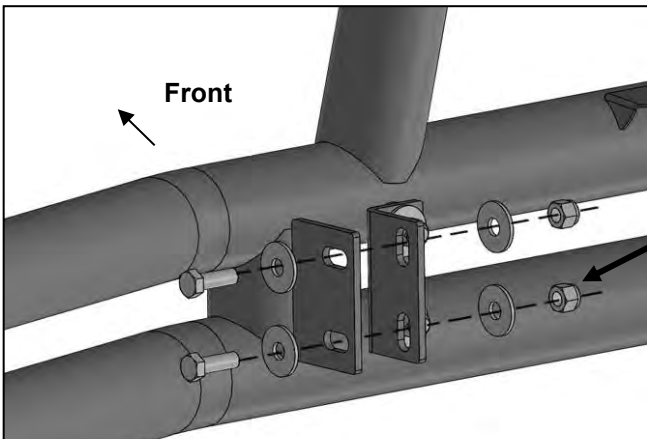

- (2) 12mm Hex Bolts
- (4) 12mm Flat Washers
- (2) 12mm Nylon Lock Nuts

(Fig 7) Driver side mounting tab on Tube Bumper attached to the outside of the Mounting Bracket

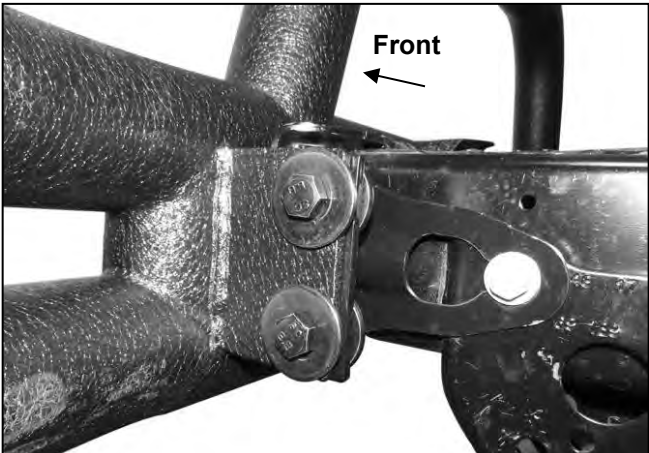

(Fig 8) Driver/left side complete install pictured



Complete Installation