



REDROCK

SPARE TIRE RELOCATION KIT
18-26 JEEP WRANGLER JL (INCL. 21-24 4XE)

PARTS LIST: J127065-JL

1	Spare Tire Carrier Relocation Bracket	2	8-1.25mm x 25mm Hex Bolts
2	Top Rectangular Spacers	8	8mm Plastic Retainers
2	Bottom Spacers	8	8mm x 24mm x 2mm Flat Washers
1	CHMSL Bracket	10	8mm x 16mm x 1.6mm Flat Washers
2	14-1.5mm x 50mm Fine Thread & 8-1.25mm x 20mm Lug Nuts	10	8mm Lock Washers
8	8-1.25mm x 55mm Hex Bolts	8	8-1.25mm Nylon Lock Nuts
4	8-1.25mm x 40mm Double Bolt Plates		

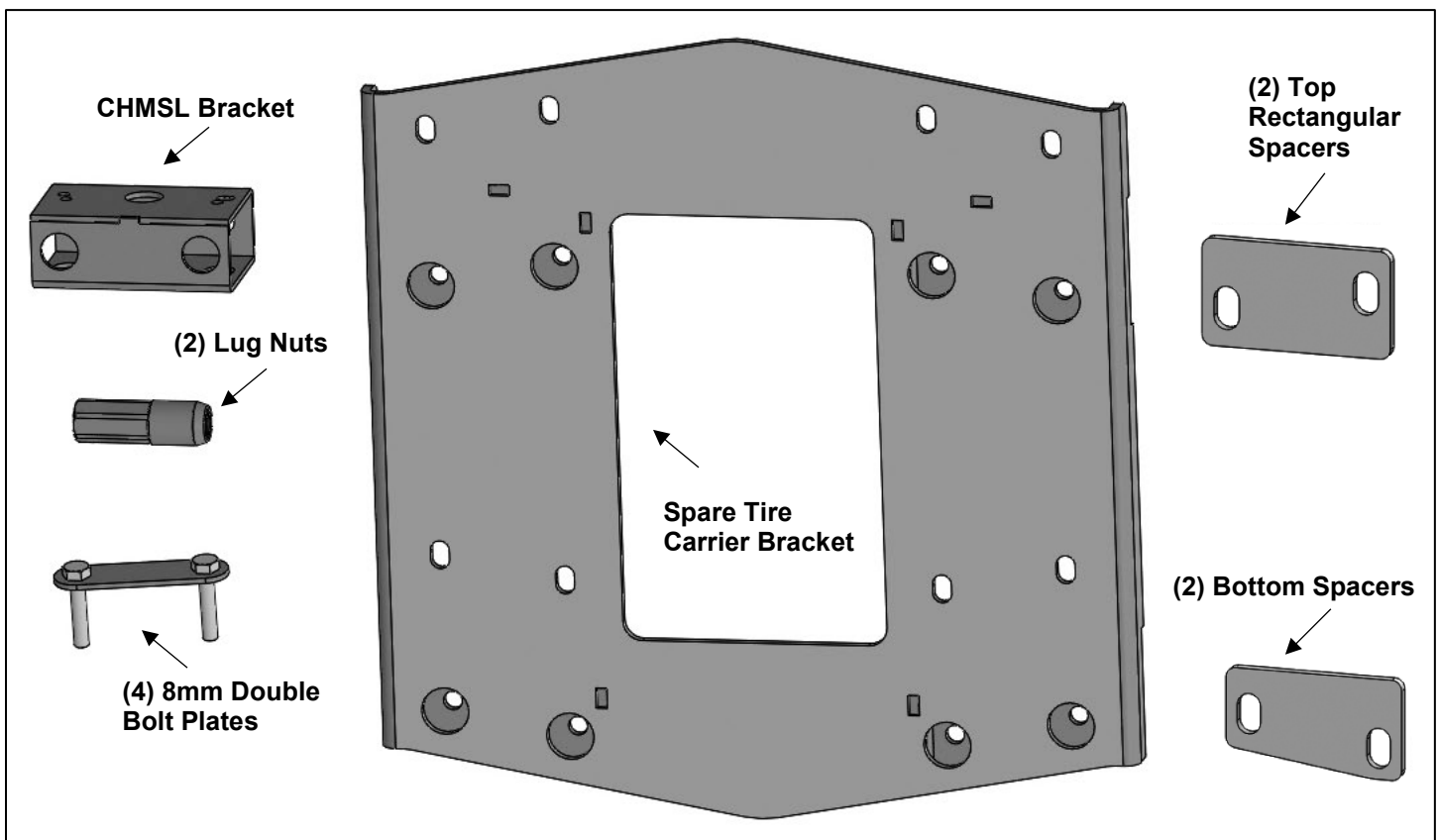

PROCEDURE:

REMOVE CONTENTS FROM BOX. VERIFY ALL PARTS ARE PRESENT. READ INSTRUCTIONS CAREFULLY BEFORE STARTING INSTALLATION. THE SPARE TIRE RELOCATION KIT CAN HOLD UP TO A 37IN DIAMETER TIRE.

1. **IMPORTANT:** Please read the following carefully and determine the proper installation.
 - a. If installing ONLY the **Spare Tire Relocation Kit**, then proceed to **Step 2**. **NOTE:** It is **highly recommended** to install the **Reinforcement Plate**, (Sold Separately), with the Spare Tire Relocation Kit.
 - OR
 - b. If installing the **Spare Tire Relocation Kit & Reinforcement Plate**, (Sold Separately), then proceed to **Step 5**. **NOTE:** Start installation with the Reinforcement Plate instructions first.

2. Start installation at the rear end of the vehicle, remove the (3) factory lug nuts holding the spare tire in place, **(Figure 1)**. Remove spare tire and set aside.
3. Next, open the tailgate and locate the camera and CHMSL, (3rd brake light), connectors, **(Figure 2)**. Unplug the connectors from the back and pull the wires out through the hole, **(Figure 3)**.
4. Remove the (8) factory bolts attaching the spare tire carrier to the tailgate and move to a stable clean surface, **(Figures 4 & 5)**.
5. Select the Spare Tire Carrier Relocation Bracket, (4) 8mm Double Bolt Plates and (8) 8mm Plastic Retainers. Insert (1) 8mm Double Bolt Plate through the back of the Bracket slots. Thread (2) 8mm Plastic Retainers up tight against the Bracket to hold the Bolt Plate in place during Bracket installation, **(Figure 6)**. Repeat this Step for the remaining (3) pairs of slots in the Bracket.
6. Select (1) Top Rectangular Spacer and (1) Bottom Spacer. Insert (2) 8mm x 55mm Hex Bolts, (2) 8mm Lock Washers and (2) 8mm x 24mm Flat Washers through the **driver/left side** large top holes of the Relocation Bracket and out through the Top Spacer holes. Repeat this step to attach the Bottom Spacer to the back of the **driver/left side** bottom of the Bracket, **(Figures 7 & 8)**.
7. **If installing both the Spare Tire Relocation Kit & the Reinforcement Plate**, then continue to **Step 9**.
8. **ONLY Spare Tire Relocation Kit installation:**
 - a. Select the remaining Top Rectangular Spacer and Bottom Spacer.
 - b. Repeat **Step 6** to install the Spacers on the **passenger/right side** of the Bracket, **(Figure 9)**.
9. Next, carefully hold the Relocation Bracket assembly up to the tailgate. Attach the Bracket to the tailgate using the (8) 8mm x 55mm Hex Bolts, (8) 8mm Lock Washers and (8) 8mm x 24mm Flat Washers, **(Figures 8 & 9)**. Center the Bracket and tighten Bracket hardware.
10. Select the factory spare tire carrier. Remove the (4) factory bolts attaching the main body of the spare tire carrier to the top CHMSL assembly, **(Figure 10)**.
11. Remove the (7) factory bolts from the top CHMSL assembly to uncover the mounting location of the light, **(Figure 11)**.
12. Remove the (2) factory bolts holding the brake light in place and unplug the connector from the light, **(Figures 12 & 13)**. Set the light aside.
13. Attach the main body of the spare tire carrier to the (4) 8mm Double Bolt Plates on the Relocation Bracket using (8) 8mm x 16mm Flat Washers and (8) 8mm Nylon Lock Nuts, **(Figure 14)**.
14. Level and adjust the spare tire carrier and tighten only the tire carrier hardware.
15. Push the camera and light connectors through the hole in the tailgate and plug in, **(Figures 2 & 3)**.
16. Reinstall the spare tire onto the tire carrier using the provided (2) **14mm/8mm** Special Lug Nuts and lower factory lug nut, **(Figure 15)**. **NOTE:** Move the light connector wire away from the spare tire.
17. Attach the CHMSL Bracket to the (2) **14mm/8mm** Lug Nuts using (2) 8mm x 25mm Hex Bolts, (2) 8mm Lock Washers and (2) 8mm x 16mm Flat Washers, **(Figure 16)**.
18. Next, run the light connector through the front center hole and up through the top center hole on the Bracket, **(Figure 17)**. Plug the connector to the light. Reuse the (2) factory bolts to attach the brake light to the top of the Bracket, **(Figure 18)**.
19. Level and center the CHMSL assembly and tighten all hardware.
20. **On installations for both the Spare Tire Relocation Kit & Reinforcement Plate:** Tighten and adjust the 10mm hardware on the door hinge to properly align the marked line or tape (See separate Reinforcement Plate instruction sheet **Step 3 & Figure 6)**.
21. Do periodic inspections to the installation to make sure that all hardware is secure and tight.

To protect your investment, wax this product after installing. Regular waxing is recommended to add a protective layer over the finish. Do not use any type of polish or wax that may contain abrasives that could damage the finish. Mild soap may be used to clean the Spare Tire Relocation Kit.



(Fig 1) Remove the (3) factory lug nuts to remove the Spare Tire from the back of the vehicle

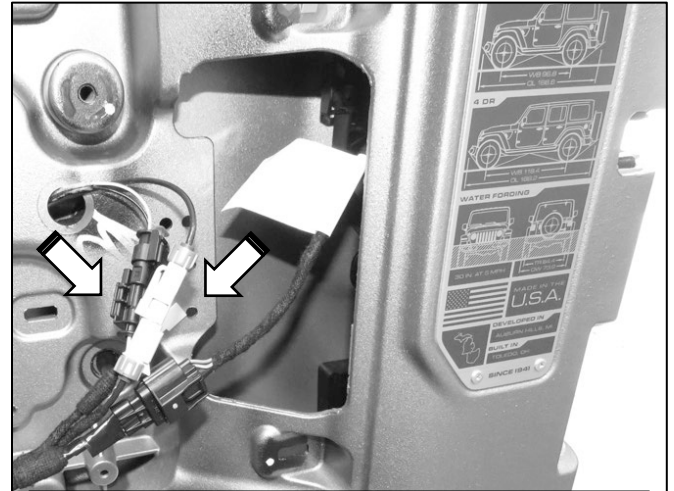

(Fig 2) Open the tailgate of the vehicle and locate the camera and light connectors

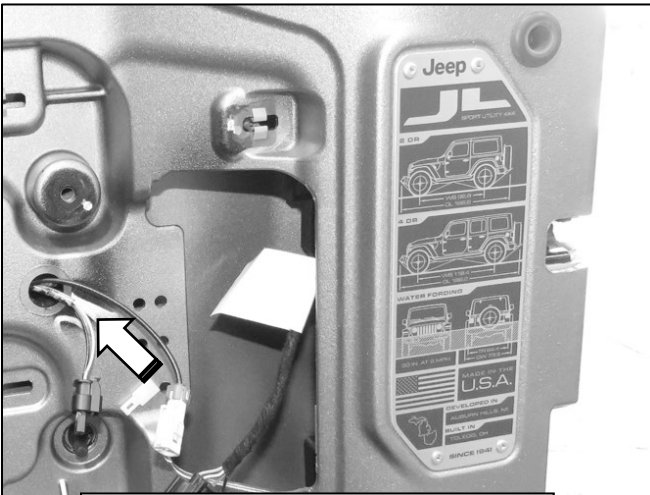

(Fig 3) Disconnect the wires and pull the wires out through the hole

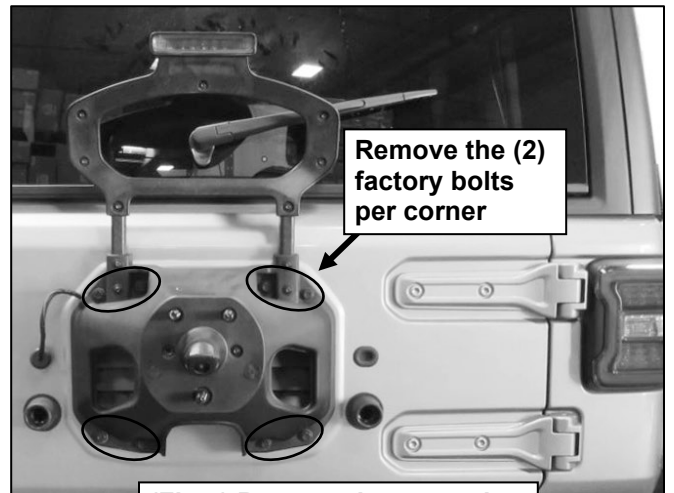

Remove the (2) factory bolts per corner

(Fig 4) Remove the spare tire carrier from the tailgate



(Fig 5) Spare tire carrier removed from tailgate

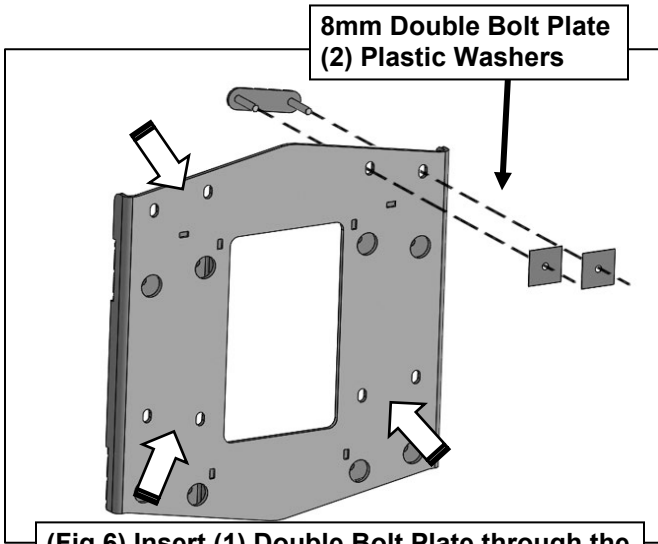

8mm Double Bolt Plate
(2) Plastic Washers

(Fig 6) Insert (1) Double Bolt Plate through the back of the Spare Tire Bracket slots and out through the front for each corner, (arrows). **NOTE:** The Plastic Washers are used to keep the Bolt Plate in place during installation.

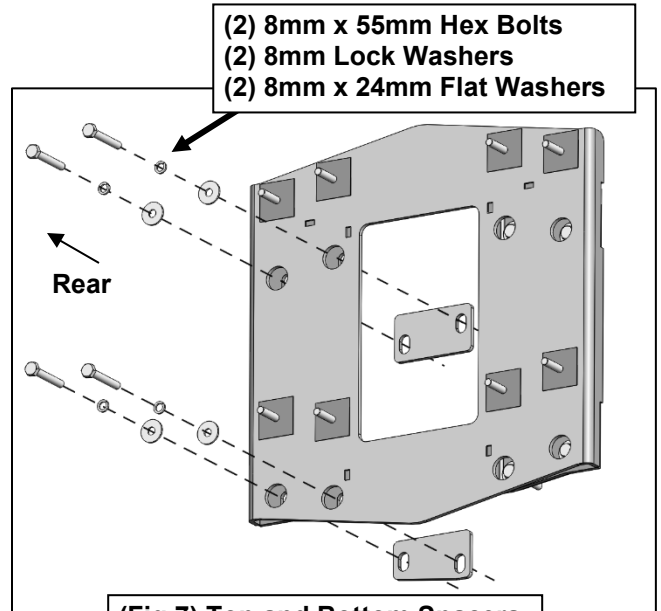

(2) 8mm x 55mm Hex Bolts
(2) 8mm Lock Washers
(2) 8mm x 24mm Flat Washers

Rear

(Fig 7) Top and Bottom Spacers attached to the Bracket

NOTE: If installing the Spare Tire Relocation Kit & the Reinforcement Bracket, then **ONLY** install the driver/left side Top and Bottom Spacers.

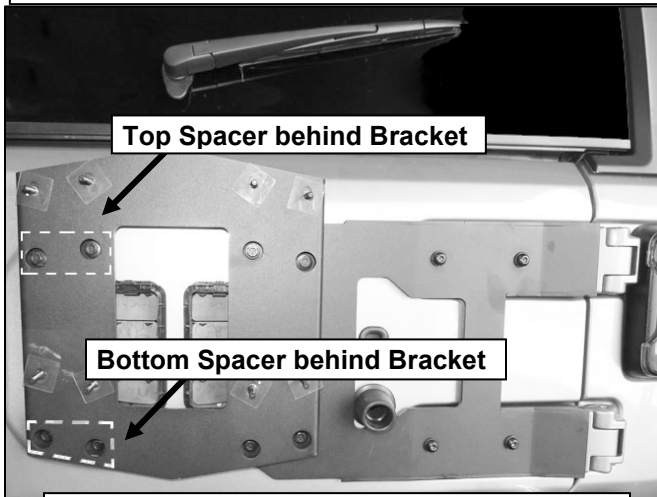

Top Spacer behind Bracket

Bottom Spacer behind Bracket

(Fig 8) Spare Tire Carrier Bracket attached to the tailgate and Reinforcement Bracket

IMPORTANT: It is highly recommended to install the Reinforcement Bracket (Sold separately) with the Spare Tire Carrier Bracket.

NOTE: If **ONLY** installing the Spare Tire Bracket, then install all 4 Top and Bottom Spacers.

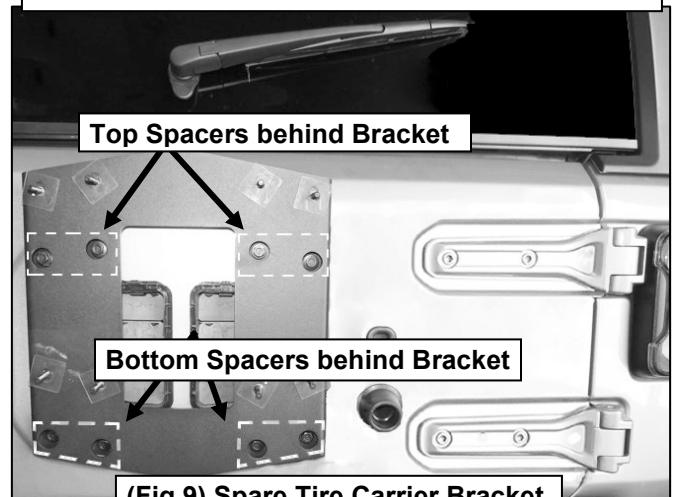

Top Spacers behind Bracket

Bottom Spacers behind Bracket

(Fig 9) Spare Tire Carrier Bracket attached to tailgate **ONLY**



(Fig 10) Remove the (4) factory bolts to detach the main body of the spare tire carrier from the top CHMSL assembly

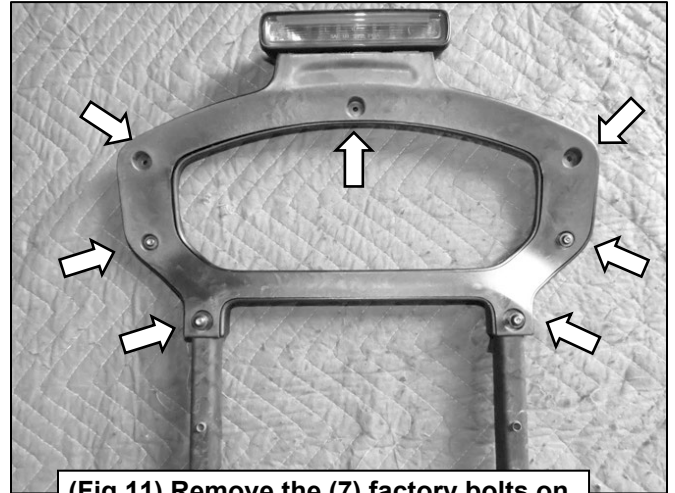

(Fig 11) Remove the (7) factory bolts on the assembly to uncover the mounting location of the CHMSL, (3rd brake light)

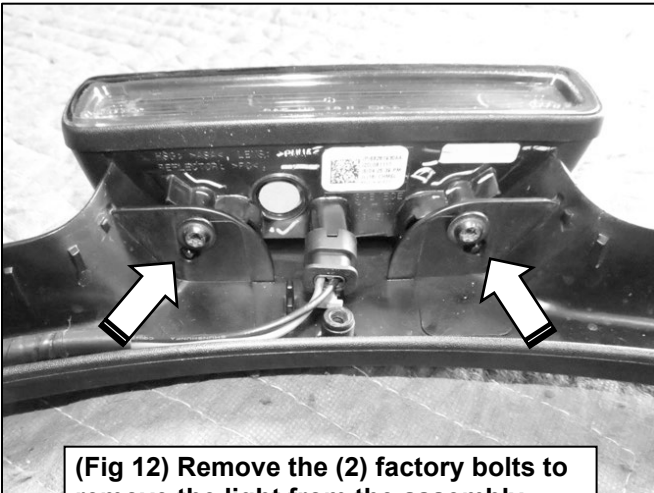

(Fig 12) Remove the (2) factory bolts to remove the light from the assembly

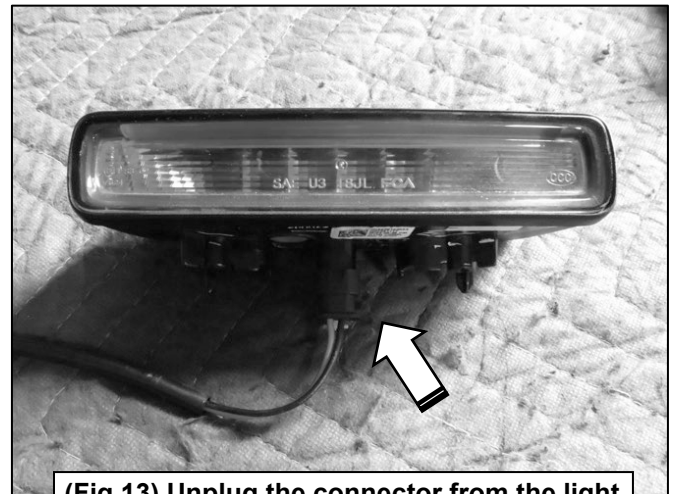

(Fig 13) Unplug the connector from the light

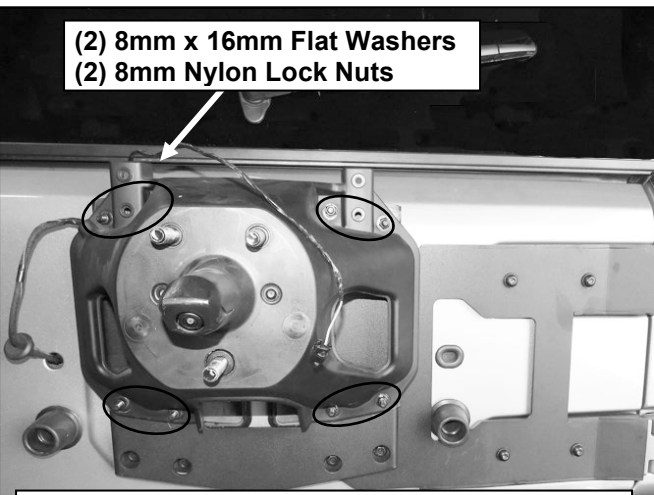

- (2) 8mm x 16mm Flat Washers
- (2) 8mm Nylon Lock Nuts

(Fig 14) Attach the main body of the spare tire carrier to the (4) Bolt Plates on the Bracket

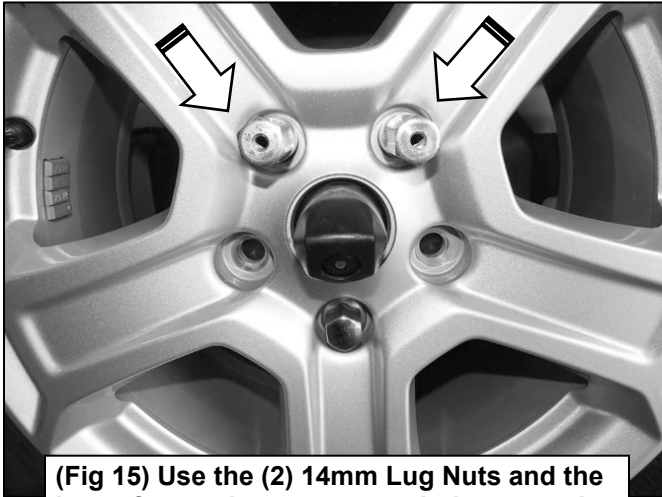

(Fig 15) Use the (2) 14mm Lug Nuts and the lower factory lug nut to attach the spare tire

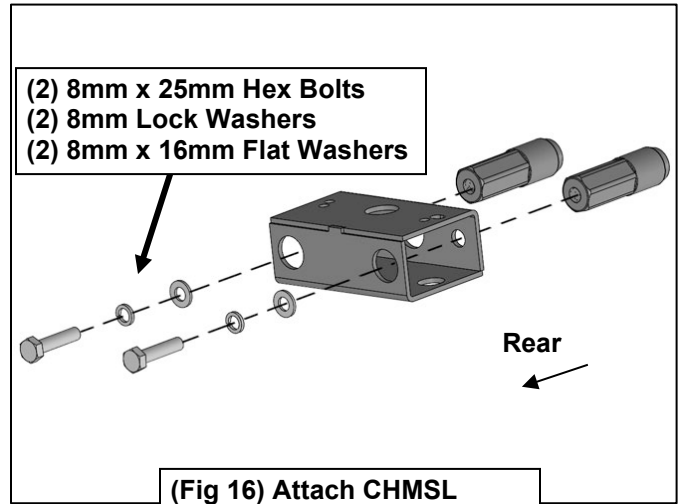

(Fig 16) Attach CHMSL Bracket to the (2) Lug Nuts

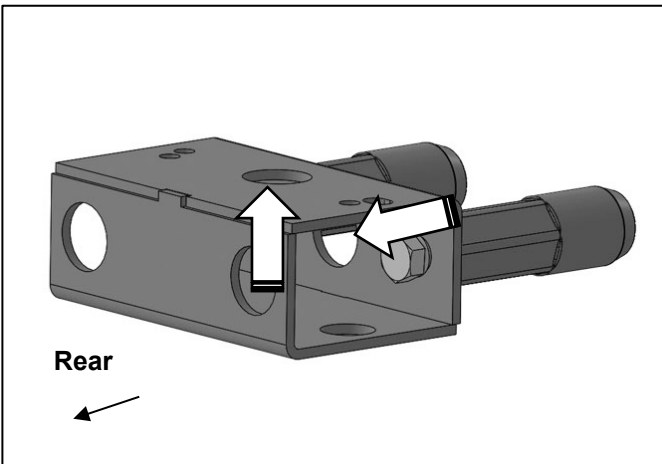

(Fig 17) Run the light wire through the front center hole and up the top center hole on the Bracket



(Fig 18) Reuse the (2) factory bolts to attach the light to the top of the Bracket



Complete