

**GT**  
**MOMENTUM™**

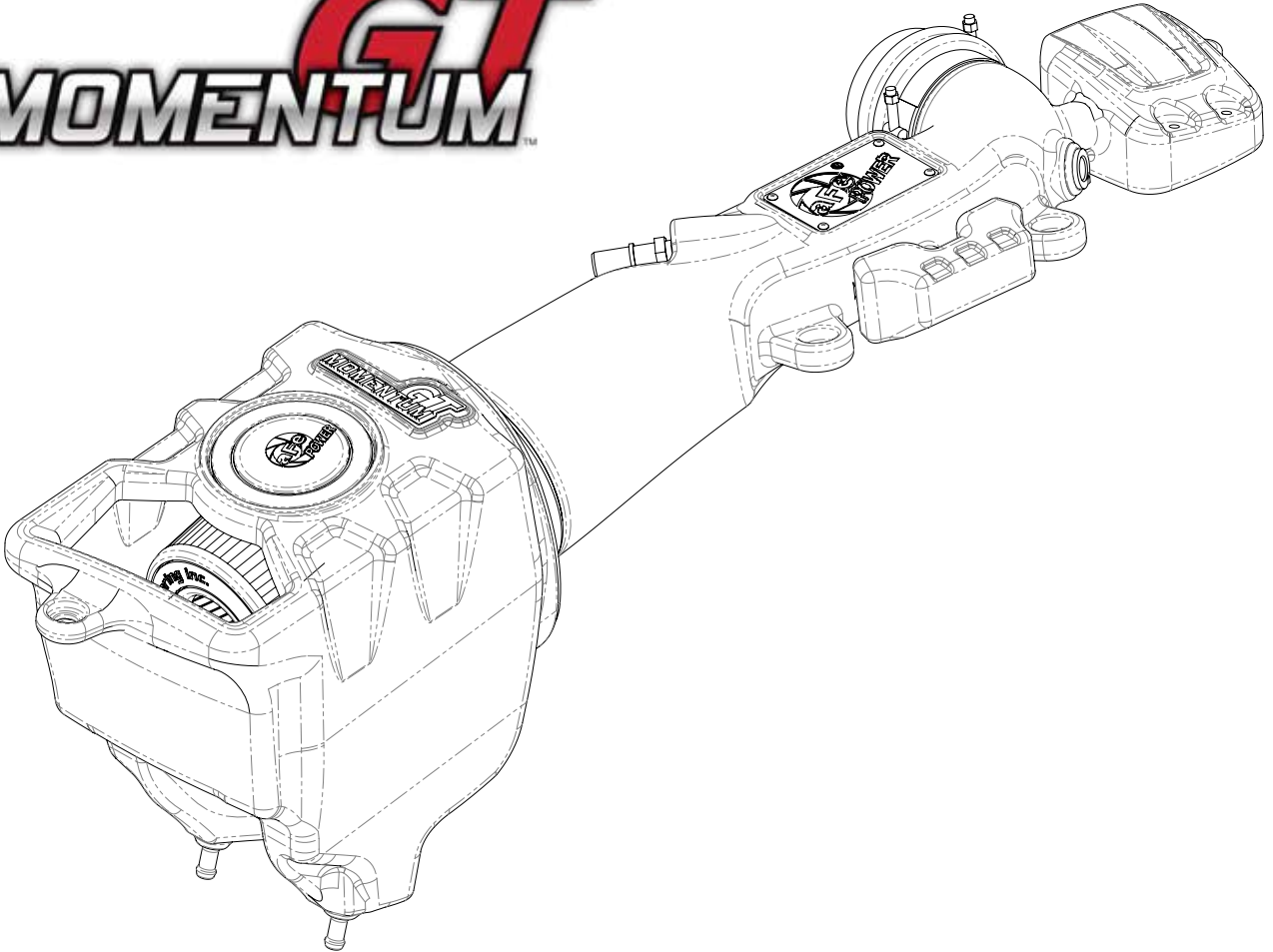

**advanced FLOW engineering** Momentum Air Intake

**Instruction Manual** P/N: 51-76217 / 54-76217 / 75-76217

Make: **Jeep** Model: **Wrangler (JL)** Year: **2018** Engine: **V6-3.6L**



- Please read the entire instruction manual before proceeding.
- Ensure all components listed are present.
- If you are missing any of the components, call customer support at 951-493-7100.
- Ensure you have all necessary tools before proceeding.
- Do not attempt to work on your vehicle when the engine is hot.
- Disconnect the negative battery terminal before proceeding.
- Retain factory parts for future use.

Label	Qty.	Description	Part Number
A1	1	Air Filter (Pro DRY S)	21-91126
A2	1	Air Filter (Pro 5R)	24-91126
A3	1	Air Filter (Pro GUARD 7)	72-91126
B	1	Tube	05-76217B1
C	1	Housing	05-76217B2
D	1	Coupling, Silicone Bellow	05-01480
E	2	Clamp, T-bolt	03-50292
F	1	Fitting, Vent Tube	05-01339
G	1	Grommet	03-50167
H	1	IAT Sensor Adaptor	05-01454

Tools needed: 8mm nut driver, 10mm deep socket and driver, 11mm deep socket or nut driver, panel popper tool, and needle nose pliers.

Note: Legal in California for use on race vehicles only. The use of this device on vehicles used on public streets or highways is strictly prohibited in California and others states that have adopted California emission regulations.

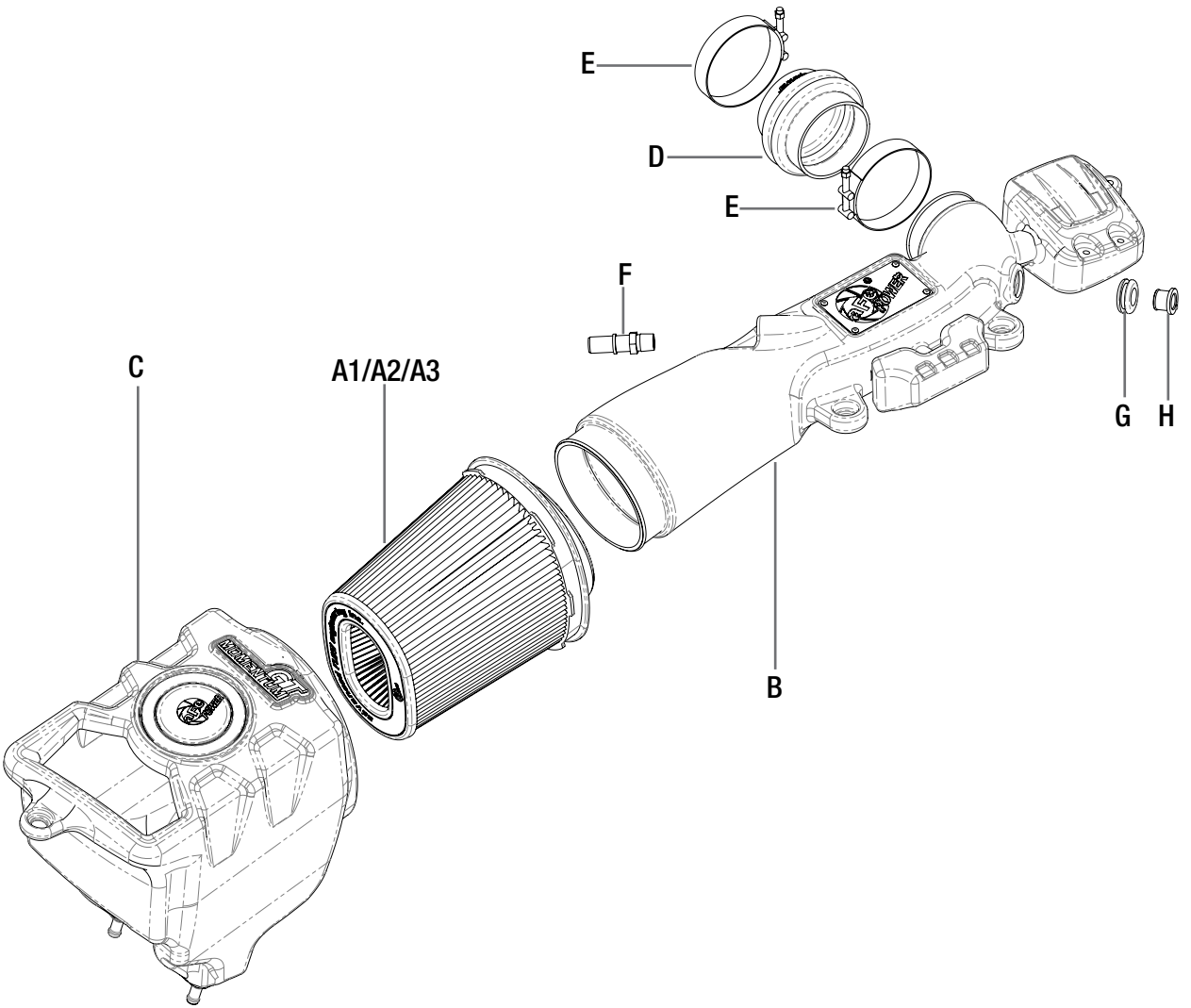

**Figure A****Refer to Figure A for Steps 1-2.**

Step 1: Remove the (3) bolts securing the intake to the vehicle using a 10mm socket and driver.

Step 2: Loosen the two clamps on the intake tube with an 8mm nut driver.

**Figure B****Refer to Figure B for Steps 3-5.**

Step 3: Disconnect the Crank Case Vent (CCV) by pushing on the grey clip and sliding the tube off the fitting.

Step 4: Disconnect the Intake Air Temperature (IAT) sensor.

Step 5: Remove the (2) connectors for the IAT sensor harness and the (1) connector for the coolant line from the right side of the intake tube. ①



**Refer to Figure C for Steps 6-8.**

Step 6: Remove the intake tube from the vehicle.

Step 7: Remove the housing from the vehicle by lifting straight upward. If the rubber grommets pop off with the housing, then remove them from the housing and place them back into the holes in the mounting bracket.

Step 8: If the connectors on the IAT sensor harness and the coolant line are bent out of shape, then repair them so that they look like the connector shown.

**Figure D****Refer to Figure D for Steps 9-13.**

- Step 9: Remove the metal sleeves and rubber grommets from the OE intake tube and reinstall them into the aFe intake tube. (2)
- Step 10: Install the grommet and temp sensor adaptor into the hole on the front of the intake tube. Make sure that the bead on the adaptor is positioned on correctly in the grommet so that it cannot pop out during use.
- Step 11: Carefully remove the IAT sensor from the OE intake tube by lifting up slightly on the plastic tab and rotating the sensor 1/4 turn counterclockwise.
- Step 12: Reinstall the IAT sensor into the temp sensor adaptor on the aFe intake tube and make sure to lock it into position by rotating it clockwise until the small tab clicks into place.
- Step 13: Install the aluminum fitting into the threaded insert on the tube and tighten it securely. Liquid Loctite or Teflon tape should be used to provide a proper seal. Do not over tighten the fitting. (3)



Figure E

**Refer to Figure E for Step 14.**

Step 14: Remove the metal sleeve and rubber grommet from the OE housing and reinstall them into the aFe housing as shown.





Figure F

**Refer to Figure F for Steps 15-16.**

- Step 15: Install the aFe housing into the vehicle by lining up the pegs into the grommets and then pressing down firmly to lock them into place. Use one of the bolts removed in Step 1 to secure the housing to the fender.
- Step 16: Install the aFe air filter into the housing and make sure that all the tabs on the filter lock into place on the housing. Leave the clamp very loose to ensure easy installation of the intake tube.

**Figure G****Refer to Figure G for Steps 17-22.**

- Step 17: Install the coupler onto the intake tube and place the clamps loosely over both ends of the coupler.
- Step 18: Insert the large end of the tube into the air filter and then rotate the coupler onto the throttle body. Make sure that the coolant line is routed on top of the intake tube before proceeding.
- Step 19: Connect the CCV to the aluminum fitting on the intake tube.
- Step 20: Plug in the IAT sensor and connect the harness to the two designated spots on the intake tube.
- Step 21: Connect the coolant line retaining clip to the designated spot on the intake tube.
- Step 22: Using the remaining bolts removed in Step 1, secure the intake tube to the core support.



Figure H

**Refer to Figure H for Steps 23-25.**

Step 23: Tighten all (3) clamps using an 11mm nut driver or a deep socket and driver. Do not over tighten the clamps.

Step 24: Verify that all connectors are secure and the (3) bolts are tightened properly.

Step 25: Your installation is now complete! Thank you for choosing aFe POWER!

**NOTE: Check all bolts, clamps, and hose connections after 100-200 miles.**



Page left blank intentionally

Page left blank intentionally



Pro DRY S Air Filter



P/N: 21-91126

Pro 5R Air Filter



P/N: 24-91126

Pro-GUARD 7 Air Filter



P/N: 72-91126

Pre-Filter



P/N: 28-10283

Pro DRY S Restore Kit



P/N: 90-59999

Blue Squeeze Restore Kit



P/N: 90-50501

Gold Squeeze Restore Kit



P/N: 90-50500

SCORCHER GT Module



P/N: 77-46205

Throttle Body Spacer



P/N: 46-35008

Loop Delete Pipe



P/N: 48-48024

Cat-Back Exhaust System



P/N: 49-48065-P (Pol. Tips)  
49-48065-B (Blk. Tips)

RaceRunner Leveling Kit

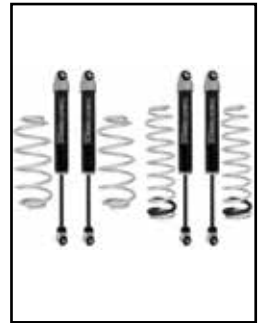

P/N: 37-L7001P

To purchase any of the items above, view airflow charts, dyno graphs, photos, and video; please go to [aFepower.com](http://aFepower.com).

# Warranty

## General Terms:

- aFe warrants their products to be free from manufacturer's defects due to workmanship and material.
- This warranty applies only to the original purchaser of the product and is nontransferable.
- Proof of purchase of the aFe product is required for all warranty claims.
- Warranty is valid provided aFe instructions for installation and/or cleaning were properly followed.
- Proper maintenance with regular inspections of product is required to insure warranty coverage.
- Damage due to improper installation, abuse, unauthorized repair or alteration is not warranted.
- Incidental or consequential damages or cost, including installation and removal of part, incurred due to failure of aFe product is not covered under this warranty.
- All warranty is limited to the repair and/or replacement of the aFe part. To request Return Goods Authorization ("RGA"), email [RGA@afepower.com](mailto:RGA@afepower.com) or call (951)493-7100. Upon receipt of the RGA, you must return the product to the address provided in the RGA, freight prepaid and accompanied with a dated proof of purchase and the RGA. Upon receipt of the defective product and upon verification of proof of purchase, aFe will either repair or replace the defective product within a reasonable time, not to exceed thirty days.

Product Category	P/N Prefix	Warranty duration
Direct OE Replacement Filters	10, 11, 30, 31, 71, 73	Life of the vehicle
Racing Filters	18	1 year
Universal	21, 24, 72	2 years
Air Intake Systems	50, 51, 54, 55, 75	2 years
Exhaust Systems	49	2 years
Intercoolers & Intercooler Tubes	46-2	2 years
Intake Manifolds	46-1	2 years
Differential Cover	46-7	Life of the vehicle
Exhaust Manifolds	46	2 years
Throttle Body Spacers	46-3	2 years
Fluid Filters	44	90 days
Pre-Filters	28	2 years
Heavy Duty OE Replacement	70	2 years
PowerSports OE Replacement	81, 87	2 years
PowerSports Intake Systems	85	2 years

No other warranty expressed or implied applies nor is any person or advanced FLOW engineering authorized to assume any other warranty. Some States do not allow the exclusion or limitation of incidental or consequential damages or do not allow limitations on how long an implied warranty lasts, so the above limitations or exclusions may not apply to you. This warranty gives you specific legal rights, and you may also have other rights which vary from State to State.

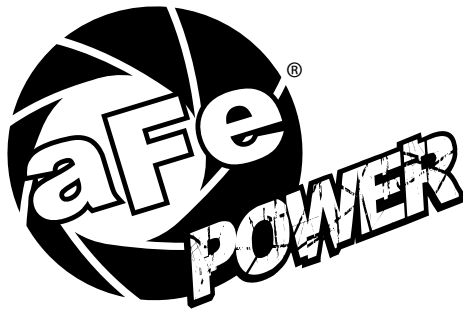

**advanced FLOW engineering, inc.**  
252 Granite Street Corona, CA 92879  
TEL: 951.493.7100 • TECH: 951.493.7134  
E-Mail: [Tech@aFepower.com](mailto:Tech@aFepower.com)