



JK Front SpeedBump Kit

www.teraflex.com

#1958251 Front Prerunner & 2.5"-3"

#1958401 Front 4"

#1958601 Front 6"

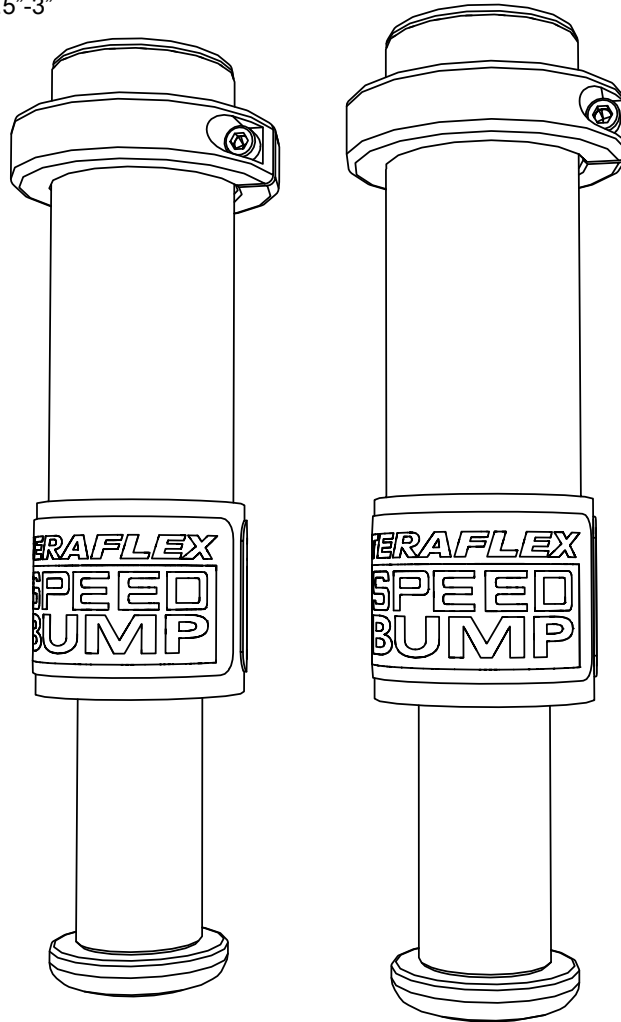

Important Notes:

Prior to beginning this or any installation read these instructions to familiarize yourself with the required steps and evaluate if you are experienced and capable to personally perform these modifications. A factory service manual should be used in conjunction with these installation instructions.

Refer to the parts list to ensure that all necessary components and hardware has been included. If any parts are missing please contact your local TeraFlex dealer for assistance.

Tools needed:

- This installation guide
- Basic mechanics tool set
- Cut-Off Tool

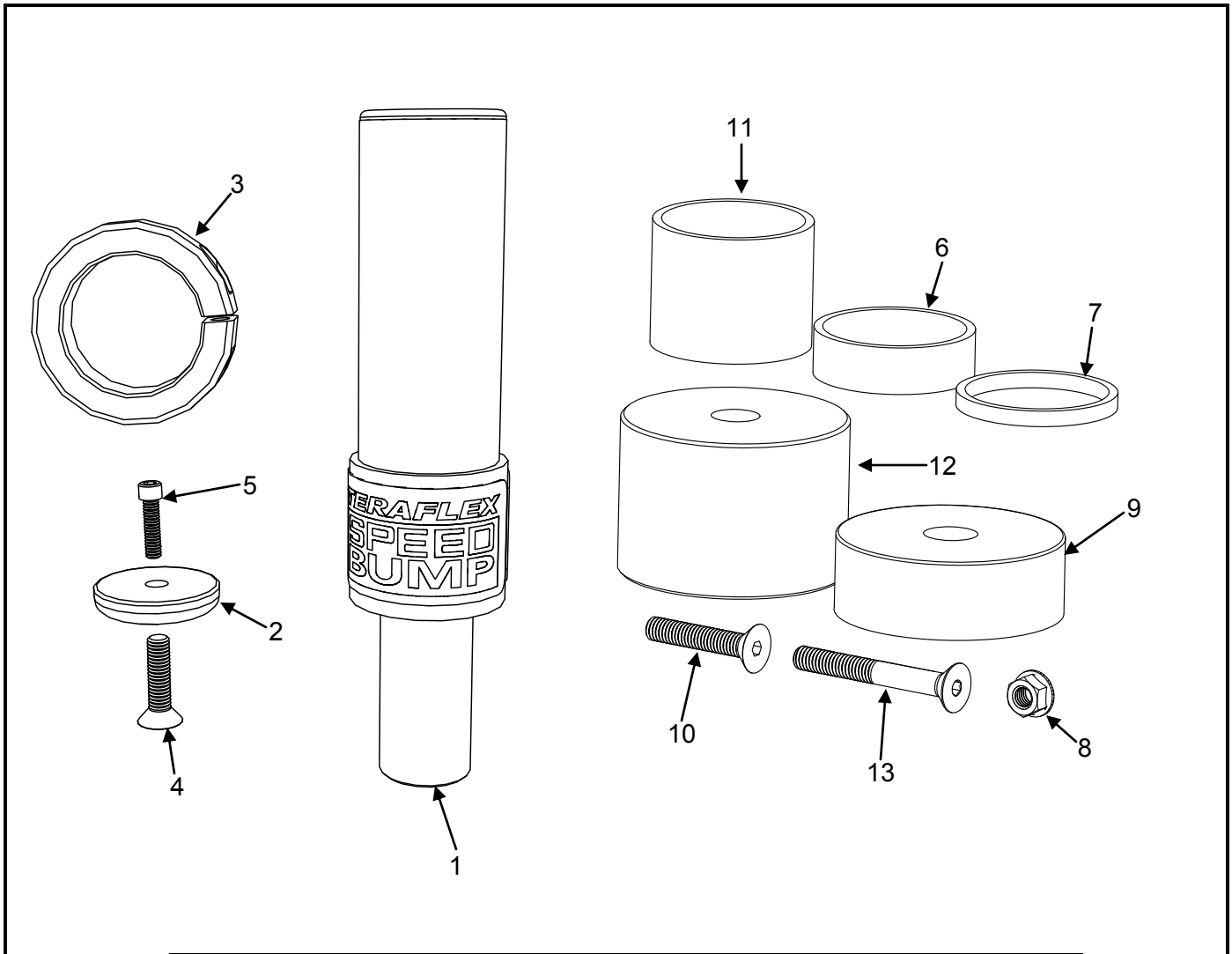

Parts List- Kit #1958251 Prerunner & 2.5"-3" Front Speedbump Kit			
Item Number	Part Number	Description	Quantity
1	953750	3" Front Speedbump	2
2	953757	Impact Tip For Bumpstop	2
3	953756	Mounting Clamp	2
4	50	Bolt 3/8-16 x 1.5 Socket Cap Screw Stainless	2
5	20	Bolt 1/4-20 x 1" Socket Cap Screw Stainless	2
6	944775	Front Spacer Sleeve 0.75"	2
7	944725	Front Spacer Sleeve 0.25"	2
8	85	Nut 3/8"-16 Flanged Serrated	2
9	467125	Front Speedbump Bumpstop 1.25" Tall	2
10	315	Bolt 3/8-16 x 2" Socket Cap Screw Black	2

Parts List- Kit #1958401 4" Front Speedbump Kit			
Item Number	Part Number	Description	Quantity
1	953900	4" Front Speedbump	2
2	953757	Impact Tip For Bumpstop	2
3	953756	Mounting Clamp	2
4	50	Bolt 3/8-16 x 1.5 Socket Cap Screw Stainless	2
5	20	Bolt 1/4-20 x 1" Socket Cap Screw Stainless	2
6	944775	Front Spacer Sleeve 0.75"	2
7	944725	Front Spacer Sleeve 0.25"	2
11	944700	Front Spacer Sleeve 2"	2
8	85	Nut 3/8"-16 Flanged Serrated	2
9	467125	Front Speedbump Bumpstop 1.25" Tall	2
10	315	Bolt 3/8-16 x 2" Socket Cap Screw Black	2

Parts List- Kit #1958601 6" Front Speedbump Kit			
Item Number	Part Number	Description	Quantity
1	953900	4" Front Speedbump	2
2	953757	Impact Tip For Bumpstop	2
3	953756	Mounting Clamp	2
4	50	Bolt 3/8-16 x 1.5 Socket Cap Screw Stainless	2
5	20	Bolt 1/4-20 x 1" Socket Cap Screw Stainless	2
6	944775	Front Spacer Sleeve 0.75"	2
7	944725	Front Spacer Sleeve 0.25"	2
11	944700	Front Spacer Sleeve 2"	2
8	85	Nut 3/8"-16 Flanged Serrated	2
12	467250	Front Speedbump Bumpstop 2.5" Tall	2
13	3151	Bolt 3/8-16 x 3" Socket Cap Screw Black	2

Park the vehicle on a level surface and set the parking brake. Raise and support the vehicle so the axle can droop. See the factory service manual for safe support locations.

1

Support the axle and disconnect the track bar at the axle with an 18mm. The nut is a flag nut.

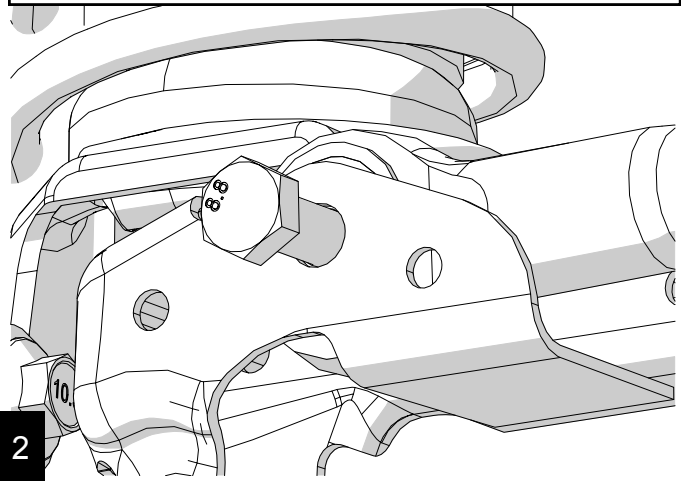

2

Disconnect the shocks from the axle with an 18mm.

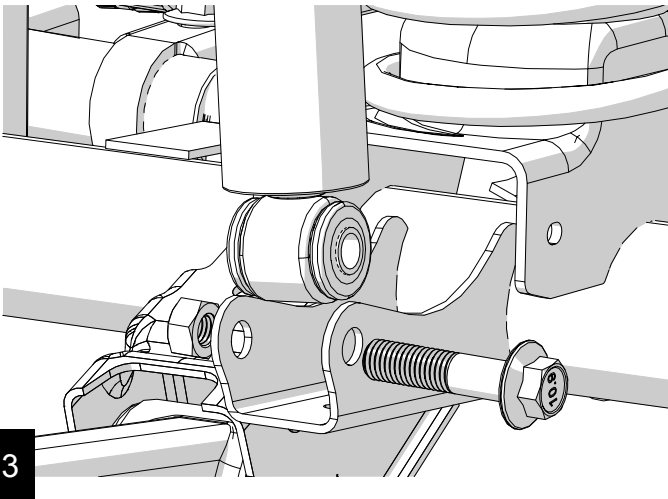

3

Lower the axle enough for the springs to be removed. Do not over stretch the ABS and brake lines.

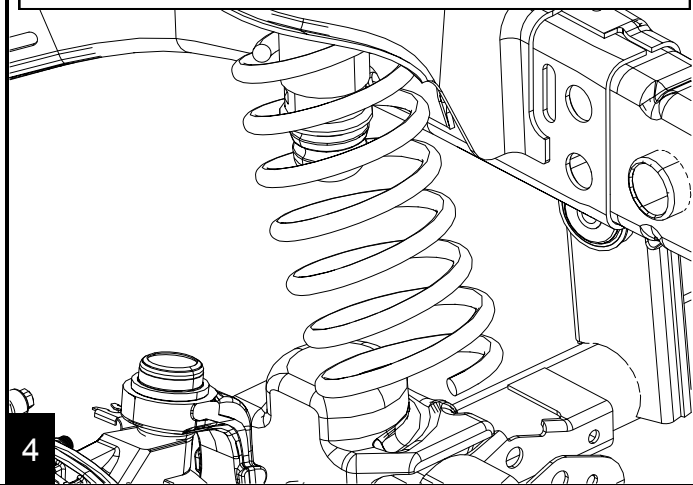

4

Remove the factory spring isolator. Remove the bumpstop by twisting and pulling to the side.

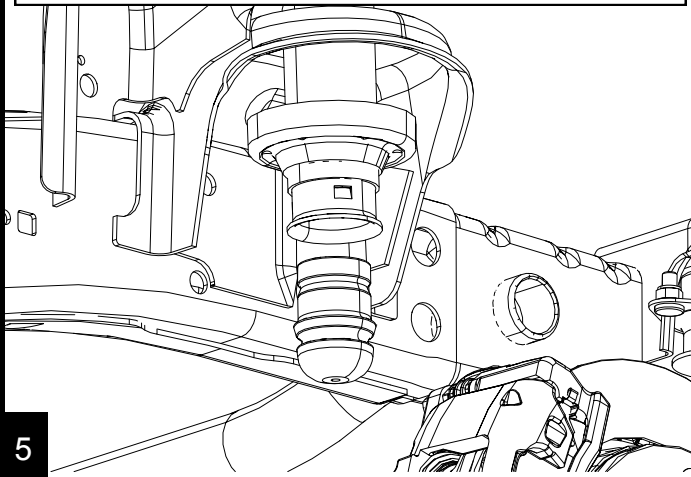

5

Measure down from the spring pocket 3.5" and mark the tube. Use tape as a straight guide for your cut. It is crucial that your cut is straight and square. Cut the tube.



6

Use a half-round file to de-burr the inner and outer edge of the tube. Check the inside of the tube for weld spatter. Remove with a chisel or file if necessary.



7

Slide the speedbump into place, check for a good fit between the speedbump and the cut factory tube.

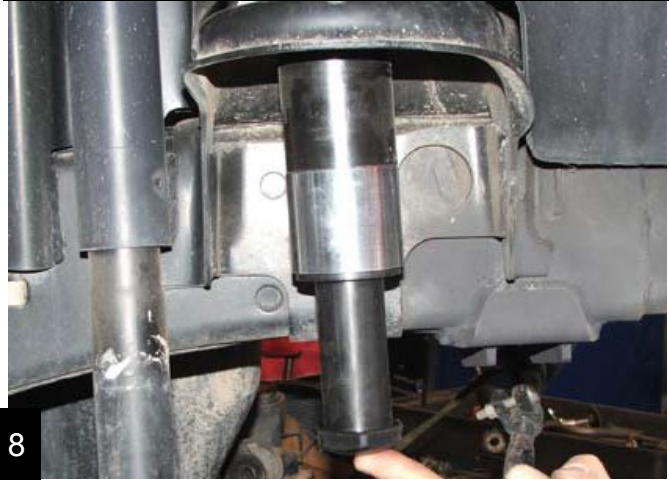

8

Remove the speedbump and center the strike pad on the spring perch. Use a center punch through the hole to mark the center.



9

Drill a 3/8" hole; We recommend first drilling a pilot hole. Set the strike pad in place for measurements.



10

With the tires on and shocks installed, cycle the suspension up until any interference occurs. Lower the axle 1/2" and measure the distance from the strike pad to the cut tube.

If the distance is 2.75" or less, remove the strike pad and adjust the speedbump with the provided spacers as required. If the distance is more than 2.75", use the provided spacers to lower the speedbump and adjust as necessary.

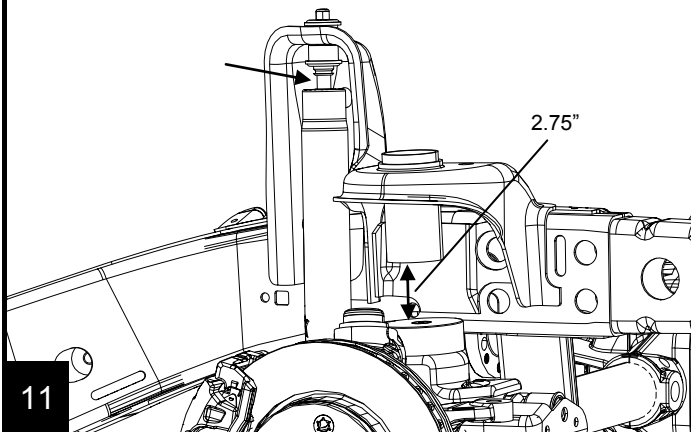

11



12

With the necessary shims in place, apply a coat of silicone sealant (not adhesive) over the cylinder of the Speedbump where it will be in contact with the factory tube.



13

Insert the speedbump into the tube, install the lock collar and torque the lock collar to 11 ft-lbs (15 Nm) Repeat process on opposite side.



14

Install the springs and strike pad as an assembly. Install the 3/8" bolt (7/32" allen) into strike pad with the nut between the spring perch and the axle. Rotate the spring until it seats in the groove.

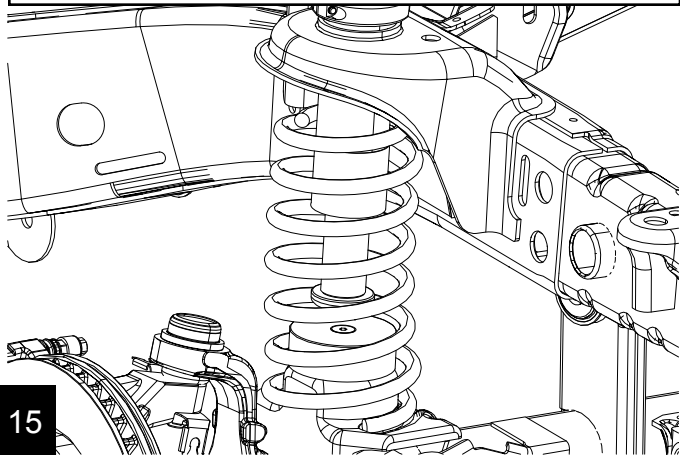

15

Reconnect the shocks, torque to 56 ft-lbs (76 Nm).

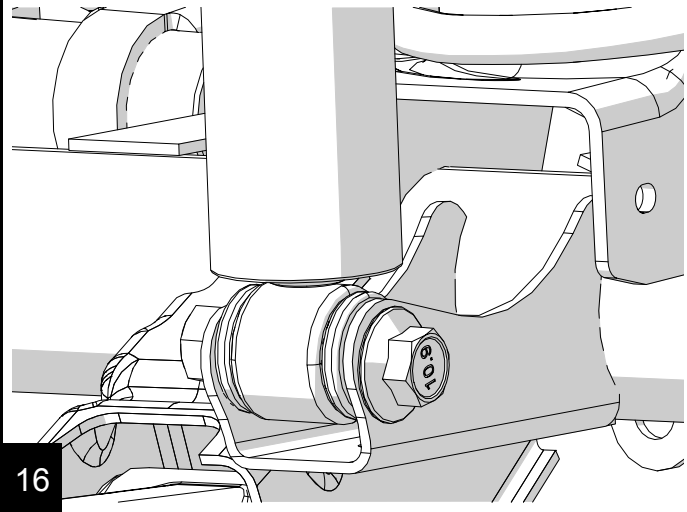

16

Reinstall the tires, torque lug nuts to 95-115 ft-lbs (128-156 Nm). Lower the vehicle to the ground and reconnect the track bar. Torque to 125 ft-lbs. Have an assistant turn the wheel back and forth to help align the track bar.

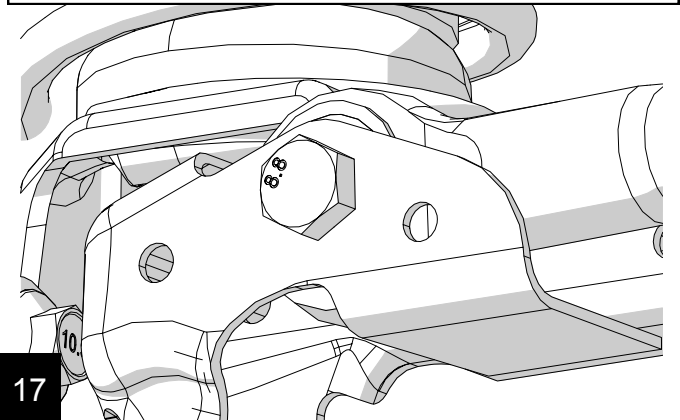

17

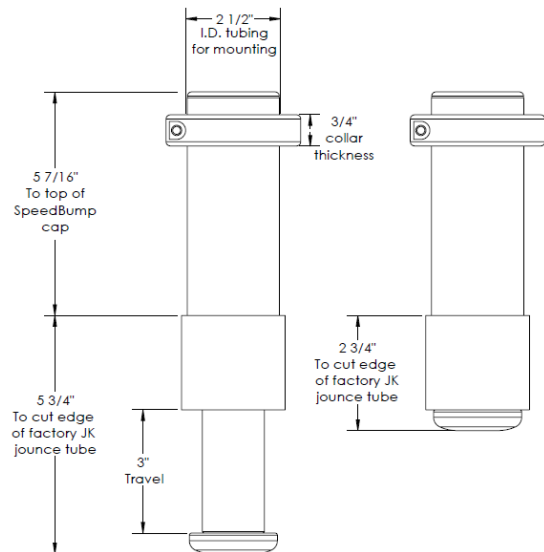

18

PRODUCT INFORMATION

MAINTENANCE INFORMATION:

It is the buyer's responsibility to have all suspension, drivetrain, steering, and other components checked for proper tightness and torque after the first 100 miles and every 3000 miles after that.

NOTICE TO INSTALLER:

The enclosed "Warning to Driver" sticker must be installed in the vehicle in driver's view. This sticker is to act as a constant safety reminder when operating the vehicle. It is your responsibility as the equipment installer to install the provided sticker and to forward the product instructions to the vehicle's owner for review. If a "Warning to Driver" sticker or product installation guide were not included in the kit, FREE replacement stickers and instructions are available by request. It is the installer's duty to ensure a safe and controllable vehicle after the modifications have been performed.

WARNING:

Neither the seller nor the manufacturer will be liable for any loss, damage, or injury directly or indirectly arising from the use of or inability to determine the use of these products. Before using, the user shall determine the suitability of the products for its intended use, and the user shall assume all responsibility and risk in connection therewith.

WARNING TO DRIVER:

This vehicle has been modified to enhance off road performance and has unique handling characteristics. Use in harsh environments can cause extreme stress on the components. Vehicle should be inspected after being off road to make sure that all the components are in working order and safe to travel on the highway. All fasteners should be checked so that they are at the correct torque specifications as the vibration and stresses from off roading may cause critical fasteners to work loose. Extra care should be taken to inspect the critical components, steering, and brake systems. During each oil change components such as arms, tie rod ends, etc should be greased and checked for excessive wear. Any worn components should be replaced. When returning to the pavement always set or restore tire air pressure to the factory recommendation and connect or engage any disabled sway bar mechanisms. Because of the higher center of gravity and larger tires, this vehicle handles and reacts differently than many passenger cars, both on and off road. You must drive it safely! Extreme care should be taken to prevent vehicle rollover or loss of control, which can result in serious injury or death. Avoid sudden sharp turns or abrupt maneuvers. Generally, braking performance and capabilities are decreased when significantly larger/heavier tires are used, especially when used in combination with transfer case low-range reduction kits. Take this into consideration while driving. Do not add, alter or fabricate any factory or aftermarket parts to increase vehicle height over the intended height of the TeraFlex product purchased. Mixing component brand is not recommended. TeraFlex Inc. will not be responsible for any altered product or any improper installation or use of our products. We will be happy to answer any questions concerning the design, function, and correct use of our products. It is ultimately the buyer's responsibility to have all bolts/nuts checked for tightness after the first 100 miles and then every 3000 miles. Wheel alignment, steering system, suspension and drive line systems must be inspected by a qualified professional mechanic at least every 3000 miles.

TERAFLEX PRODUCT WARRANTY:

TeraFlex Inc. warrants TeraFlex Suspension products to the original retail purchaser to be free of defects in material and workmanship for as long as the original purchaser owns the vehicle on which products were originally installed.

Failure to complete regular maintenance (grease every 3000 miles) on TeraFlex FlexArms will void this warranty. All other conditions of the standard TeraFlex product warranty apply.

All TeraLow products are covered by the TeraFlex two (2) year warranty to be free of defects in material and workmanship for two years from date purchased.

TeraFlex axles are covered by a 12-month warranty to be free of defects in materials and workmanship.

This warranty does not cover or include product finish, improperly installed or applied products, improperly maintained products, products or components used for racing or competition or damage due to abuse or neglect, products that fail due to the use of larger tire and wheel combinations.

All returns must be accompanied by an original invoice. It is the customer's responsibility to remove the product from the vehicle. Shipping charges are the responsibility of the customer. TeraFlex Inc. will pay the return freight if the product meets the terms of warranty.

This warranty is for the replacement or repair of defective TeraFlex products only and does not include freight charges, labor charges for removal of or installation of TeraFlex or related products or components, costs incurred due to down time of the vehicle, or lost profits due to vehicle down time.

A returned goods authorization number (RGA#) must accompany any returned products. For more information please contact a TeraFlex customer service representative.

COPYRIGHT

©Copyright 2014. All rights reserved, TeraFlex Inc. Reproduction of this catalog and/or any of its contents without written permission is strictly prohibited.

TeraFlex® is a registered trademark of TeraFlex Inc. All trade names and logos including but not limited to TeraFlex, FlexArms, RockGuard, Monster, and LCG are protected by law and duplication of trade names and/or logos are strictly prohibited.

TeraFlex Inc. reserves the right to update, discontinue, redesign, modify finish, part number or component build parts if deemed necessary without written notice.

TeraFlex Inc., and any associated dealers are not responsible for misprints or typographical errors that may have inadvertently been made within this instruction sheet.

Jeep® and the Jeep® grill are registered trademarks of Fiat Chrysler Automobiles N.V., and have no affiliation with TeraFlex Inc.

TERAFLEX, Inc.

5680 West Dannon Way
West Jordan, Utah 84081
Phone/801.713.3314
Fax/801.713.2313
www.teraflex.com



JK Rear Speedbumps

www.teraflex.com

#1954760 Rear 3"-4"

#1958602 Rear 6"



Important Notes:

Prior to beginning this or any installation read these instructions to familiarize yourself with the required steps and evaluate if you are experienced and capable to personally perform these modifications. A factory service manual should be used in conjunction with these installation instructions.

Teraflex Speedbump kits require at least 3" of lift for proper function.

Refer to the parts list to ensure that all necessary components and hardware has been included. If any parts are missing please contact your local TeraFlex dealer for assistance.

Tools needed:

- This installation guide
- Basic mechanics tool set

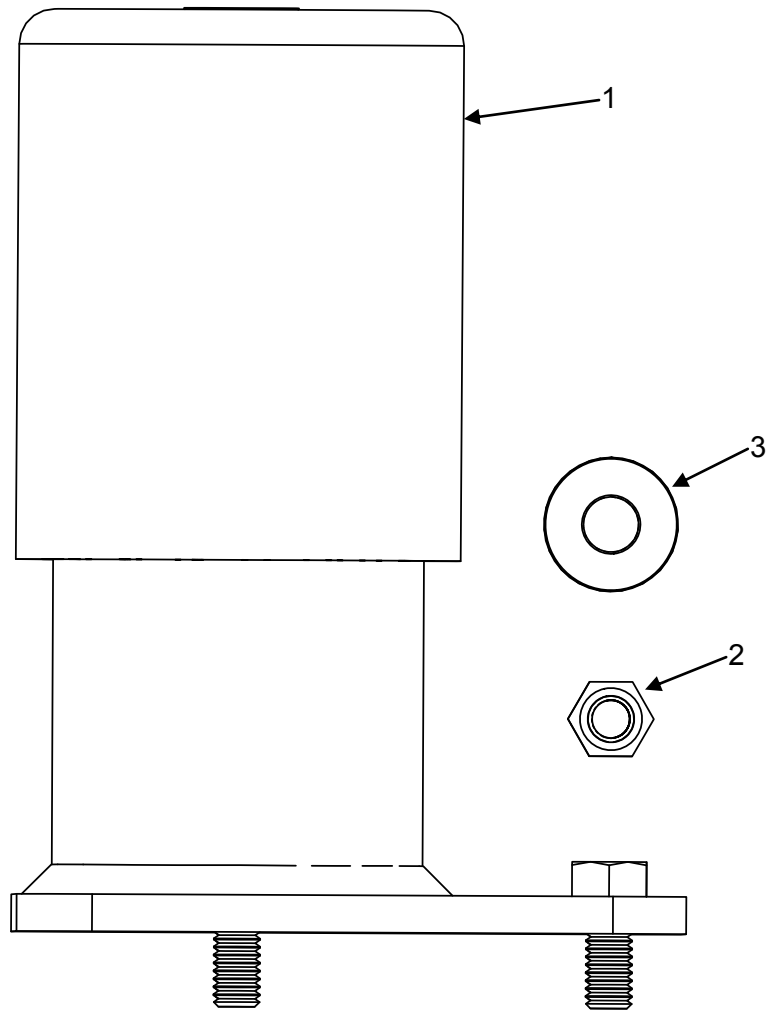

Parts List- Kit #1744014			
Item Number	Part Number	Description	Quantity
1	954760	Speed Bump Rear JK Complete Assembly	2
2	632	Nut 5/16-16 Stover Locknut	4
3	38	Washer 5/16" Flat Zinc	4

If you have a lift kit installed, remove any existing bumpstop extensions.



Install the speedbump with the cylinder towards the front of the vehicle. The studs will install into the factory holes in the axle bracket.

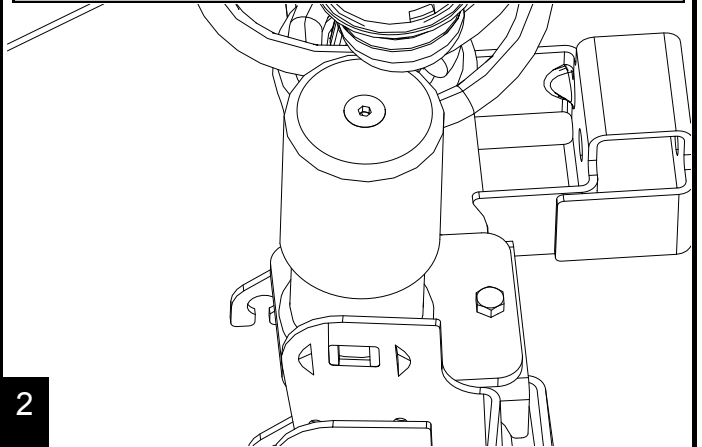

Install the washers and nuts. Torque to 30 ft-lbs. For 3"-4" kits, install is complete.

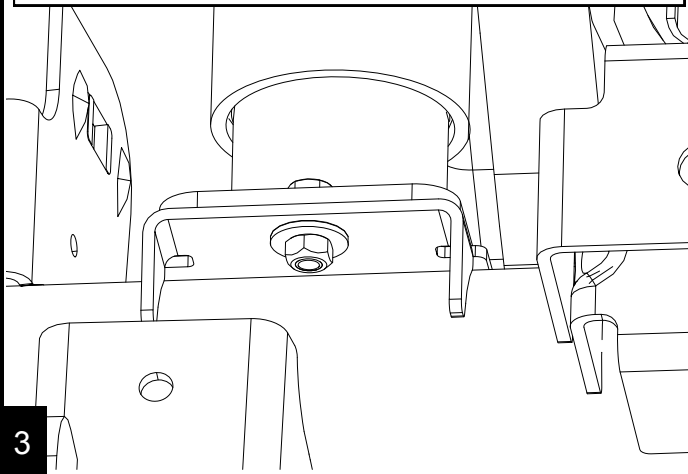

For 6" Applications Only: Remove the factory bumpstop from the cup on the frame by twisting and pulling to the side.

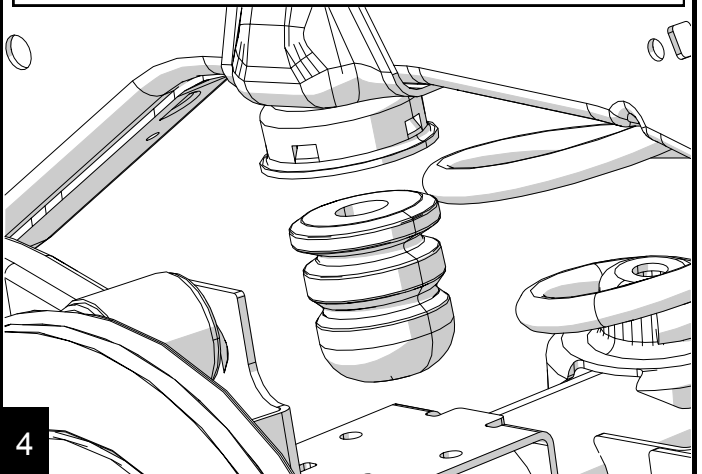

Apply grease to the bumpstop and the extension. Or just the strike pad.

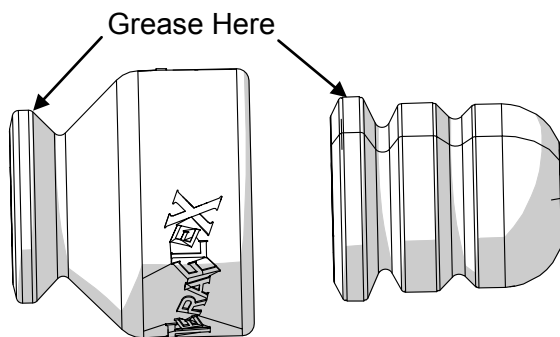

Place a block between the frame and the axle bump pad. Raise the axle until the bumpstop and extension seat.

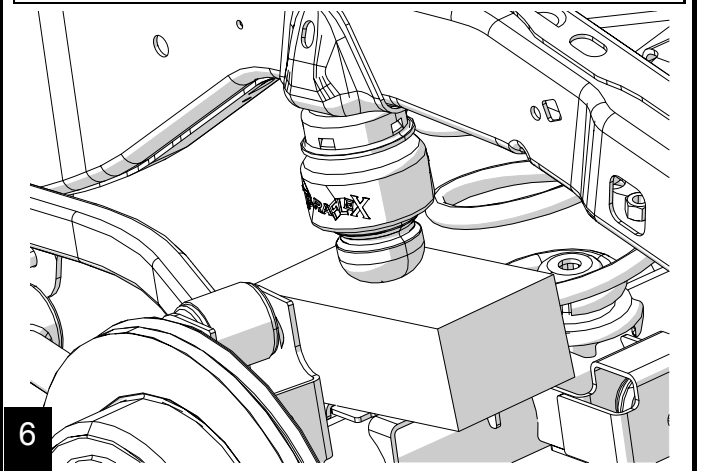

PRODUCT INFORMATION

MAINTENANCE INFORMATION:

It is the buyer's responsibility to have all suspension, drivetrain, steering, and other components checked for proper tightness and torque after the first 100 miles and every 3000 miles after that.

NOTICE TO INSTALLER:

The enclosed "Warning to Driver" sticker must be installed in the vehicle in driver's view. This sticker is to act as a constant safety reminder when operating the vehicle. It is your responsibility as the equipment installer to install the provided sticker and to forward the product instructions to the vehicle's owner for review. If a "Warning to Driver" sticker or product installation guide were not included in the kit, FREE replacement stickers and instructions are available by request. It is the installer's duty to ensure a safe and controllable vehicle after the modifications have been performed.

WARNING:

Neither the seller nor the manufacturer will be liable for any loss, damage, or injury directly or indirectly arising from the use of or inability to determine the use of these products. Before using, the user shall determine the suitability of the products for its intended use, and the user shall assume all responsibility and risk in connection therewith.

WARNING TO DRIVER:

This vehicle has been modified to enhance off road performance and has unique handling characteristics. Use in harsh environments can cause extreme stress on the components. Vehicle should be inspected after being off road to make sure that all the components are in working order and safe to travel on the highway. All fasteners should be checked so that they are at the correct torque specifications as the vibration and stresses from off roading may cause critical fasteners to work loose. Extra care should be taken to inspect the critical components, steering, and brake systems. During each oil change components such as arms, tie rod ends, etc should be greased and checked for excessive wear. Any worn components should be replaced. When returning to the pavement always set or restore tire air pressure to the factory recommendation and connect or engage any disabled sway bar mechanisms. Because of the higher center of gravity and larger tires, this vehicle handles and reacts differently than many passenger cars, both on and off road. You must drive it safely! Extreme care should be taken to prevent vehicle rollover or loss of control, which can result in serious injury or death. Avoid sudden sharp turns or abrupt maneuvers. Generally, braking performance and capabilities are decreased when significantly larger/heavier tires are used, especially when used in combination with transfer case low-range reduction kits. Take this into consideration while driving. Do not add, alter or fabricate any factory or aftermarket parts to increase vehicle height over the intended height of the TeraFlex product purchased. Mixing component brand is not recommended. TeraFlex Inc. will not be responsible for any altered product or any improper installation or use of our products. We will be happy to answer any questions concerning the design, function, and correct use of our products. It is ultimately the buyer's responsibility to have all bolts/nuts checked for tightness after the first 100 miles and then every 3000 miles. Wheel alignment, steering system, suspension and drive line systems must be inspected by a qualified professional mechanic at least every 3000 miles.

TERAFLEX PRODUCT WARRANTY:

TeraFlex Inc. warrants TeraFlex Suspension products to the original retail purchaser to be free of defects in material and workmanship for as long as the original purchaser owns the vehicle on which products were originally installed.

Failure to complete regular maintenance (grease every 3000 miles) on TeraFlex FlexArms will void this warranty. All other conditions of the standard TeraFlex product warranty apply.

All TeraLow products are covered by the TeraFlex two (2) year warranty to be free of defects in material and workmanship for two years from date purchased.

TeraFlex axles are covered by a 12-month warranty to be free of defects in materials and workmanship.

This warranty does not cover or include product finish, improperly installed or applied products, improperly maintained products, products or components used for racing or competition or damage due to abuse or neglect, products that fail due to the use of larger tire and wheel combinations.

All returns must be accompanied by an original invoice. It is the customer's responsibility to remove the product from the vehicle. Shipping charges are the responsibility of the customer. TeraFlex Inc. will pay the return freight if the product meets the terms of warranty.

This warranty is for the replacement or repair of defective TeraFlex products only and does not include freight charges, labor charges for removal of or installation of TeraFlex or related products or components, costs incurred due to down time of the vehicle, or lost profits due to vehicle down time.

A returned goods authorization number (RGA#) must accompany any returned products. For more information please contact a TeraFlex customer service representative.

COPYRIGHT

©Copyright 2014. All rights reserved, TeraFlex Inc. Reproduction of this catalog and/or any of its contents without written permission is strictly prohibited.

TeraFlex® is a registered trademark of TeraFlex Inc. All trade names and logos including but not limited to TeraFlex, FlexArms, RockGuard, Monster, and LCG are protected by law and duplication of trade names and/or logos are strictly prohibited.

TeraFlex Inc. reserves the right to update, discontinue, redesign, modify finish, part number or component build parts if deemed necessary without written notice.

TeraFlex Inc., and any associated dealers are not responsible for misprints or typographical errors that may have inadvertently been made within this instruction sheet.

Jeep® and the Jeep® grill are registered trademarks of Fiat Chrysler Automobiles N.V., and have no affiliation with TeraFlex Inc.

TERAFLEX, Inc.
5680 West Dannon Way
West Jordan, Utah 84081
Phone/801.713.3314
Fax/801.713.2313
www.teraflex.com