



## **FITTING INSTRUCTIONS**

**Part Number:** 3450210      **F/KIT:** 6172210

**Product Description:**      **JEEP ROCK CRAWLER BAR**

**Suited to vehicle/s:**      **CHRYSLER WRANGLER JK JEEP 2006 ON**

### **WARNING**

- ◆ This product must be installed exactly as per these instructions using only the hardware supplied.
- ◆ In the event of damage to any bull bar component, contact your nearest authorised ARB stockist.
- ◆ Do not use this product for any vehicle make or model, other than those specified by ARB.
- ◆ Do not remove labels from this bull bar.
- ◆ This product or its fixing must not be modified in any way.
- ◆ The installation of this product may require the use of specialized tools and/or techniques
- ◆ It is recommended that this product is only installed by trained personnel
- ◆ These instructions are correct as at the publication date. ARB Corporation Ltd. cannot be held responsible for the impact of any changes subsequently made by the vehicle manufacturer
- ◆ During installation, it is the duty of the installer to check correct operation/clearances of all components
- ◆ Work safely at all times
- ◆ Unless otherwise instructed, tighten fasteners to specified torque

---

## **ARB 4x4 ACCESSORIES**

### **Corporate Head Office**

42-44 Garden St  
Kilsyth, Victoria  
AUSTRALIA 3137

**Tel:** +61 (3) 9761 6622  
**Fax:** +61 (3) 9761 6807

Australian enquiries  
North & South American enquiries  
Other international enquiries

[sales@arb.com.au](mailto:sales@arb.com.au)  
[sales@arbusa.com](mailto:sales@arbusa.com)  
[exports@arb.com.au](mailto:exports@arb.com.au)

[www.arb.com.au](http://www.arb.com.au)

# GENERAL CARE AND MAINTENANCE

By choosing an ARB Bar, you have bought a product that is one of the most sought after 4WD products in the world. Your bar is a properly engineered, reliable, quality accessory that represents excellent value. To keep your bar in original condition it is important to care and maintain it following these recommendations.

- Prior to exposure to the weather your bar should be treated to a Canuba based polish on all exposed surfaces. It is recommended that this is performed on a six monthly basis or following exposure to salt, mud, sand or other contaminants.
- As part of any Pre Trip Preparation, or on an annual basis, it is recommended that a thorough visual inspection of the bar is carried out, making sure that all bolts and other components are torqued to the correct specification. Also check that all wiring sheaths, connectors, and fittings are free of damage. Replace any components as necessary.
- Please contact local Authorised ARB Stockist if you would like to have this service carried out on your behalf.

## HAVE AVAILABLE THESE SAFETY ITEMS WHEN FITTING PRODUCT:

### BASIC TOOL KIT

Protective eyewear



Hearing protection



**NOTE:** 'WARNING' notes in the fitting procedure relate to OHS situations, where to avoid a potentially hazardous situation it is suggested that protective safety gear be worn or a safe work procedure be employed. If these notes and warnings are not heeded, injury may result.

## FASTENER TORQUE SETTINGS:

SIZE	Torque Nm	Torque lbft
M6	9Nm	4lbft
M8	22Nm	16lbft
M10	44Nm	32lbft
M12	77Nm	57lbft

**OPTIONAL LIGHT SETS TO SUIT THIS PRODUCT:**  
Up to IPF 900 SERIES FOG OR DRIVING LIGHT SETS

**WARN WINCHES TO FIT THIS PRODUCT**  
MID SIZE FRAME 6000LB – 9500LB  
TI SERIES 9500LB  
POWER PLANT 9500LB – 12000LB  
RC SERIES 9000LB

USE	PART No	QTY	DESCRIPTION
TO FIT BAR TO VEHICLE CHASSIS	6151357	8	BOLT M10 x 1.5 x 30mm SEMS ASSY
	6151168	2	BOLT M12 X 1.75 X 80mm
	4581050	2	WASHER SPRING 1/2"
	4581049	2	WASHER FLAT 1/2"
	3199848	2	NUT PLATE CAGED M12
	6151305	2	NUT CAGED M12 X 1.75
	5848342	2	PACKER
CONTROL BOX BRACKET	6151021	2	BOLT M8 x 20mm
	4581044	2	WASHER FLAT M8
	3756262	1	CONTROL BOX BRACKET
	6151132	2	NUT FLANGE M8
LIGHT BRACKETS	3757047	2	BRACKETS LIGHT BOLT ON
	6151021	4	BOLT M8 X 25MM
	4581063	8	WASHER FLAT M8 GOLD ZINC
	6151212	4	NUT NYLOC M8
NUMBER PLATE BRACKET ASSEMBLY	6151180	4	BOLT M6 x 20MM
	6151017	2	BOLT M6 X 16MM
	5848302	2	PACKER NYLON BLACK
	4581072	4	WASHER FLAT M6 x 13mm
	6151128	4	NUT FLANGE M6
	6151162	2	NUT NYLOC M6
	3757048	1	NUMBER PLATE MOUNT
	3757049	1	NUMBER PLATE PIVOT
WINCH FITMENT	180302	10	CABLE TIES
	6151073	2	BOLT 3/8" X 1 1/2"
	4581040	6	WASHER FLAT M10
	6151357	2	BOLT M10 x 1.5 x 30mm SEMS ASSY
	6151321	2	NUT FLANGE M10
WING BRACE TO WINGS	4681011L	1	BRACE WING LHS
	4681011R	1	BRACE WING RHS
	6151021	8	BOLT M8 X 25MM
	4581044	8	WASHER FLAT M8
	4581046	8	WASHER SPRING M8
	6151132	8	NUT FLANGE M8

**ASSEMBLY SEQUENCE FOR BULL BAR INSTALLATION.  
PLEASE READ AND UNDERSTAND FITTING INSTRUCTIONS BEFORE  
ATTEMPTING TO FIT BAR TO VEHICLE**



**1. To fit a bar to vehicle, the plastic bumper and all hardware behind bumper must be removed from vehicle.**

**See photos below.**

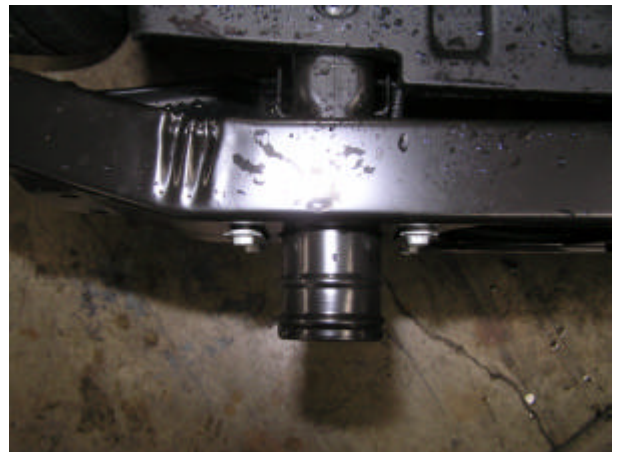



**2. This is how the vehicle must be prepared before fitting a bar to the vehicle.**

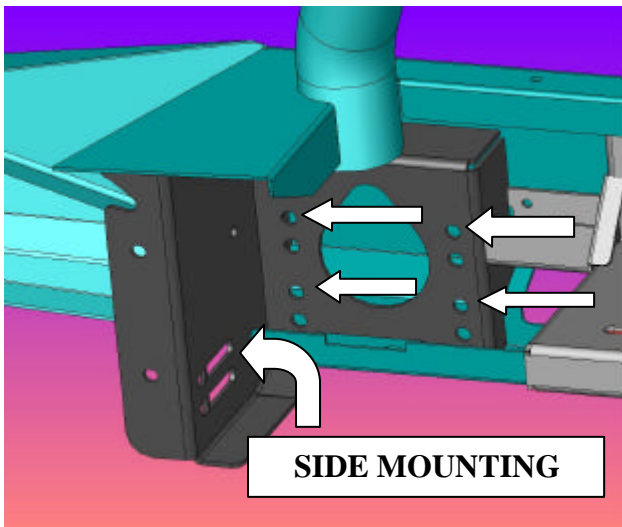

**3. Arrows indicate which bolt holes to use when fitting the bar to the vehicle.**

**4. The set of mounting holes under arrowed holes are for vehicles that have been fitted with a body lift kit.**

**I.e. This set of mounting holes will lift the bar 25mm.**

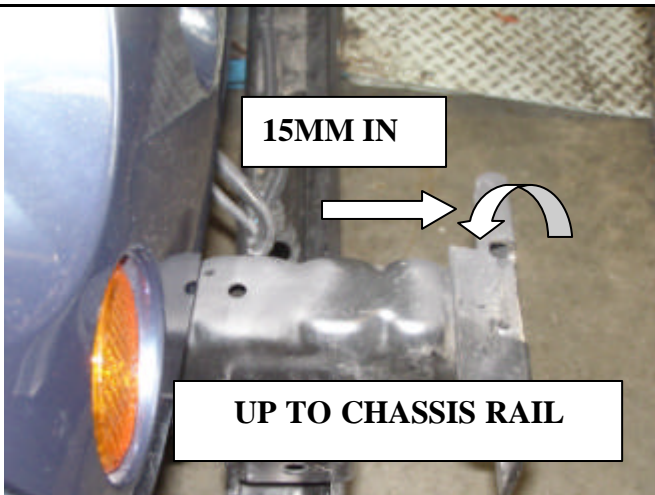

**5. If a winch is going to be fitted, the right hand side mounting plate on end of chassis has to be notched for winch clearance.**

**6. Cut top flange up to chassis rail and 15mm in.**

**VIEWED FROM RHS OF VEHICLE**

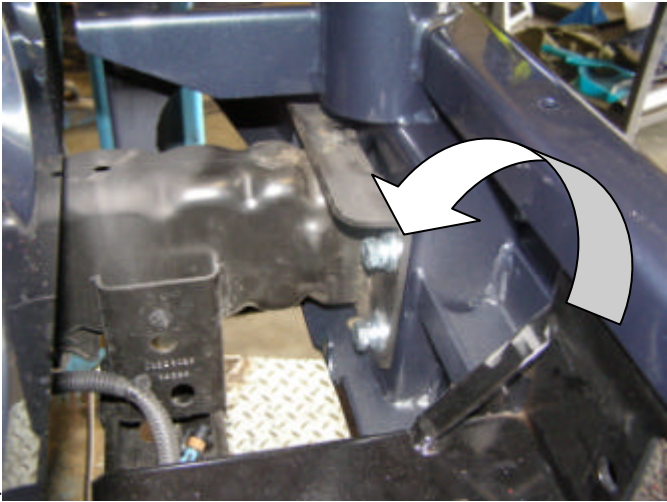

**6. With the help of a friend, lift bar onto chassis and secure using 10mm hardware, Finger tighten only.**

**4 BOLTS PER SIDE**

**VIEWED FROM LHS OF VEHICLE**

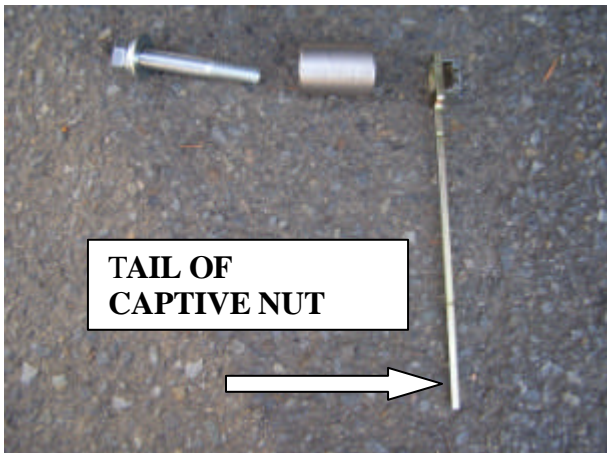

**TAIL OF  
CAPTIVE NUT**

**Set up RHS of vehicle**

**7. This hardware is for side mounting as per paragraph 3-4**



**Caged nut fitted to nut plate**

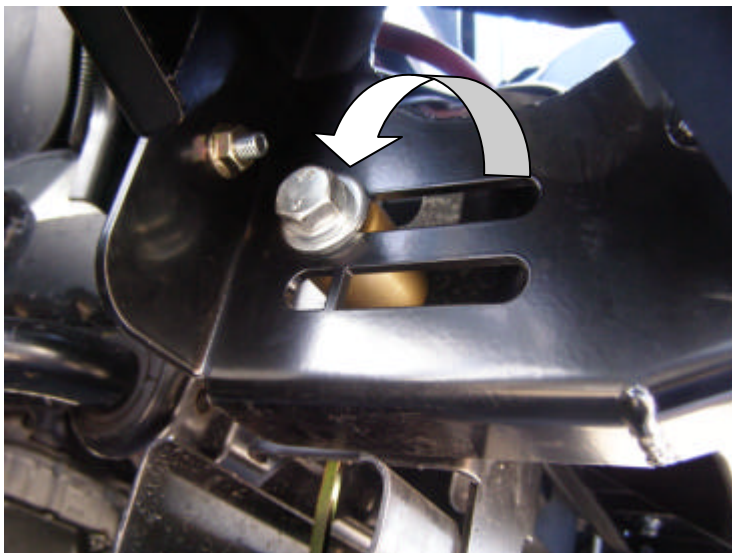

**VIEWED FROM UNDER RHS OF VEHICLE.**

**8. Packer fits in between inside of chassis rail and bar in rear part of captive slot**

**9. Pass 12mm bolt plus washers through outside of bar, through packer and just protruding into chassis rail.**

**10. Pass caged nut assembly into open end of chassis rail and secure with previously fitted 12mm bolt, see photo on paragraph 11.**

**YOU WILL HAVE TO BEND  
TAIL OF CAPTIVE NUT PLATE  
TO FIT INTO CHASSIS RAILS.**

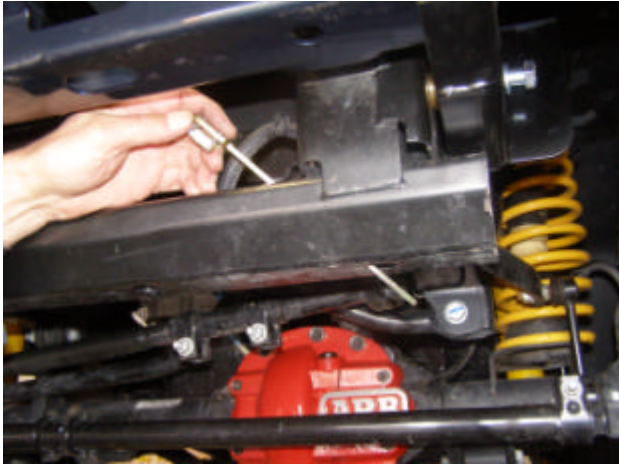

**11. Pass caged nut plate from top through crossmember, then upwards into open end of chassis rails.**



**12. When all bolts are tighten to correct torque, brake off the part of the captive nut plate which hangs through the hole in vehicle crossmember with a pair of pliers.**



**TOP VIEW LHS OF VEHICLE.**

- 13. If a number plate is to be fitted to vehicle, you must assemble as per photo opposite.**
- 14. To assemble, using a 6mm x 25mm bolt, flat washer, pass through outer frame, fit black nylon packer then pass through inner frame and secure using a 6mm nyloc nut.**
- 15. Tighten just enough so the assembly can pivot.**
- 16. The reason for a pivoting number plate assembly is to allow the number plate to pivot up when the winch is being operated.**



**17. When the number plate assembly is assembled, fit to bar using 6mm x 25mm bolt plus 6mm hardware.**

**18. Tighten bolts to torque specifications.**



**WINCH MOUNTING PLATFORM**

**19. As mentioned above, this bar can be fitted with a series of different Warn winches.**

**20. If a mid size frame type winch is to be used, a control box bracket has to be fitted to bar.**

**21. Lower winch onto mounting platform of bar. Fit 3/8" square nuts into winch retaining cavities.**

**22. Bolt up from under bar using 3/8" x 1 1/2" bolts, spring and flat washers**



**23. Fit control box bracket to bar using M8 x 25mm bolts plus 8mm hardware.**

**24. Fit control box to control box bracket and wire up winch as per Warn instructions.**

**25. Cable tie all power cables together and keep clear of all moving parts, hot parts and sharp edges.**

**26. If a RC Series winch is to be fitted, the same as above applies except the RC winch has its own bolt on control box mount.**



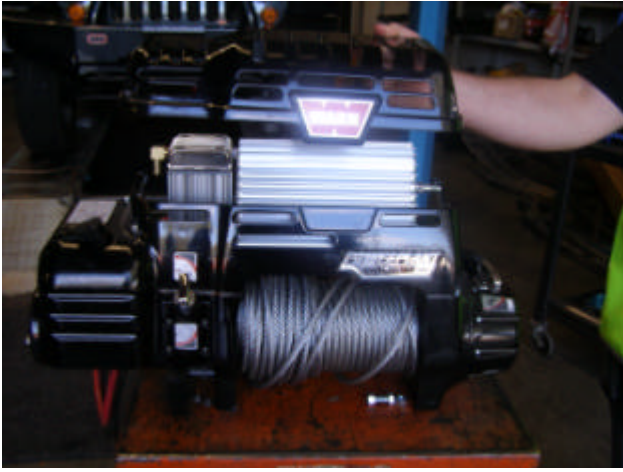

**27. If a Power Plant 9500LB – 12000LB is going to be used. The top compressor cover must be removed by undoing the 4 capped head screws.**



- 27. Place protective cloths over top of bar and lift winch onto winch mounting platform.**
- 28. Refit top cover.**
- 29. Secure and wire up the same method as paragraph 21-22.**
- 30. Winch has built in control box feature, therefore no control box bracket required.**

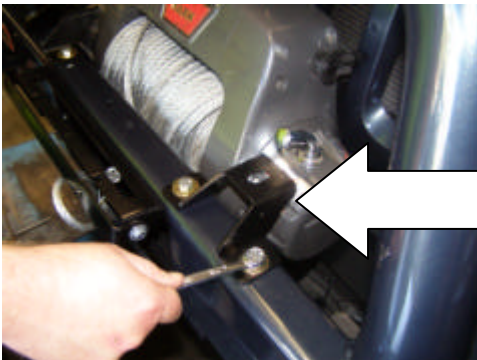

- 31. Lastly, fitting a TI 9500LB winch, is same as paragraph 21-22-30.**
- 32. If fitting lights to bar, the light mounting brackets must be fitted at this stage.**
- 33. The brackets is bolted to bar using 8mm hardware and secured using a 8mm nyloc nuts.**
- 34. The bracket faces towards the winch so when the lights are fitted the high lift jack, if used, does not hit the light.**
- 35. If lights are going to be fitted to a bar fitted with a power plant winch, the brackets face outwards, therefore a hi lift jack cannot be used.**



Hold nyloc nut  
Using 1/4" drive  
Ratchet with  
extension

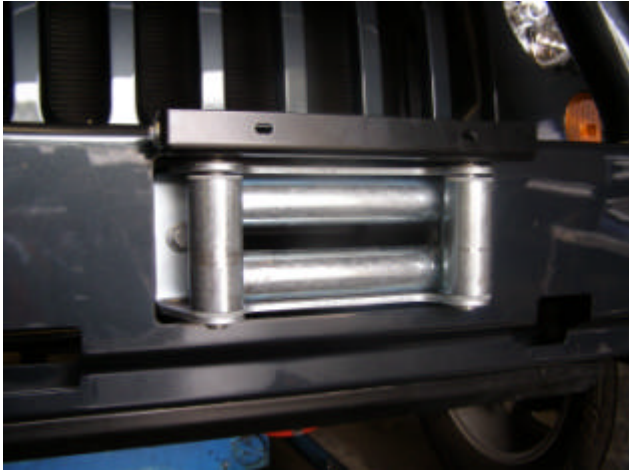

**36. The next part to fit to bar is the roller fairlead. This is secured to bar using 10mm hardware.**

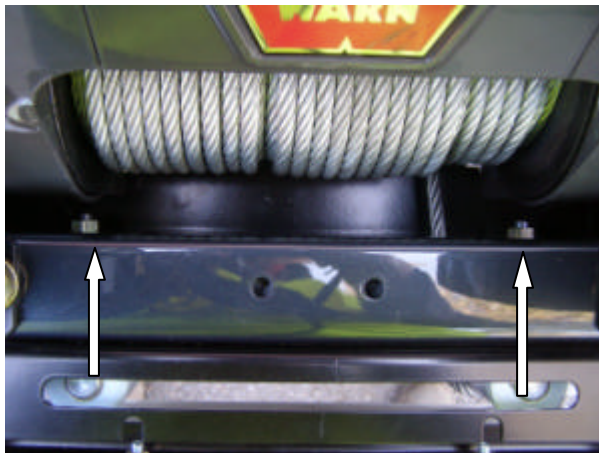

**37. Pass 10mm bolt assembly through front of roller fairlead, through bar and secure from behind using a 10mm flange nut.**

**ARROWS INDICATE 10MM FLANGE NUTS**



**38. Fit wing braces to bar using 8mm hardware.**

**39. When all bolts are fitted, tighten to torque specifications.**





**Bolt number plate to number plate bracket using 6mm hardware.**



**Number Plate in up position during winching**



**PHOTO IS A OPTIONAL COLOURED BAR**