



## Installation Instructions

Standard Rear Seat (Part # 80xxN)  
1955-1995 CJ & Wranglers

### Installation Instructions: Standard tilt forward rear seat (1955-1995) CJ – YJ

#### Rear Seat Installation

1. Remove seat mounting bolts from floor.
2. Remove the following parts from parts bag:
  - (i) 2 EA Mounting Bracket
  - (ii) 2 EA Flat Washer
  - (iii) 2 EA Hex Nuts (M8 x P1.25)
  - (iv) 2 EA Hex Bolts (M8 x P1.25 x 1.50)
3. Locate mounting tabs on the bottom of the seat and cut a slit 2" long to expose tabs. They are located about 4" from each side of the seat bottom.

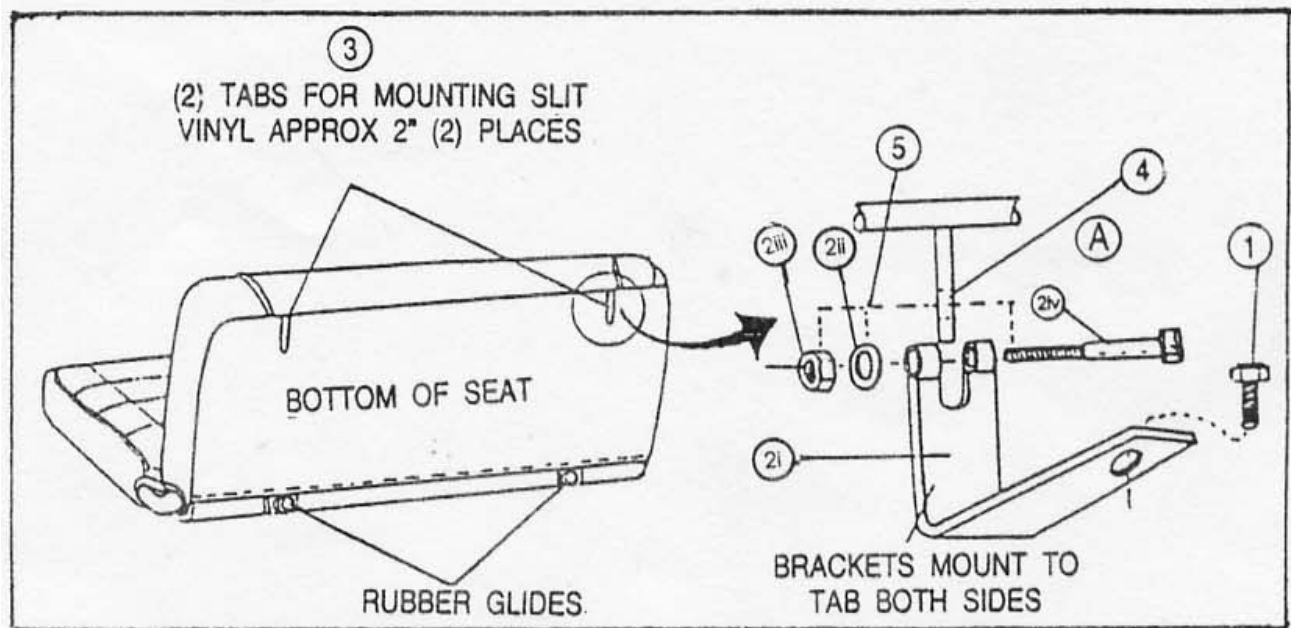

4. Put hinge bolts through front mounting bracket and tab.
5. Install washer and hex nut on threaded bolt. DO NOT OVER TIGHTEN.
6. Align mounting tab over front mounting holes and securely tighten with seat mounting bolt.

For Technical Support/Warranty Information please call 310-762-9944

Smittybilt, 400 West Artesia Blvd, Compton, CA 90220



## Installation Instructions

Standard Rear Seat (Part # 80xxN)  
1955-1995 CJ & Wranglers

### Rear Seat Lock

1. Remove seat belt anchor bolt from floor.
2. Position lock underneath seat belt & eyelets as shown. Please note that more than one hole is supplied to align the bracket with the floor mounting hole and seat lock. If desired an additional hole can be drilled and the bracket secured with two bolts. Grade 5 or higher bolt and large washer are recommended (supplied by customer).

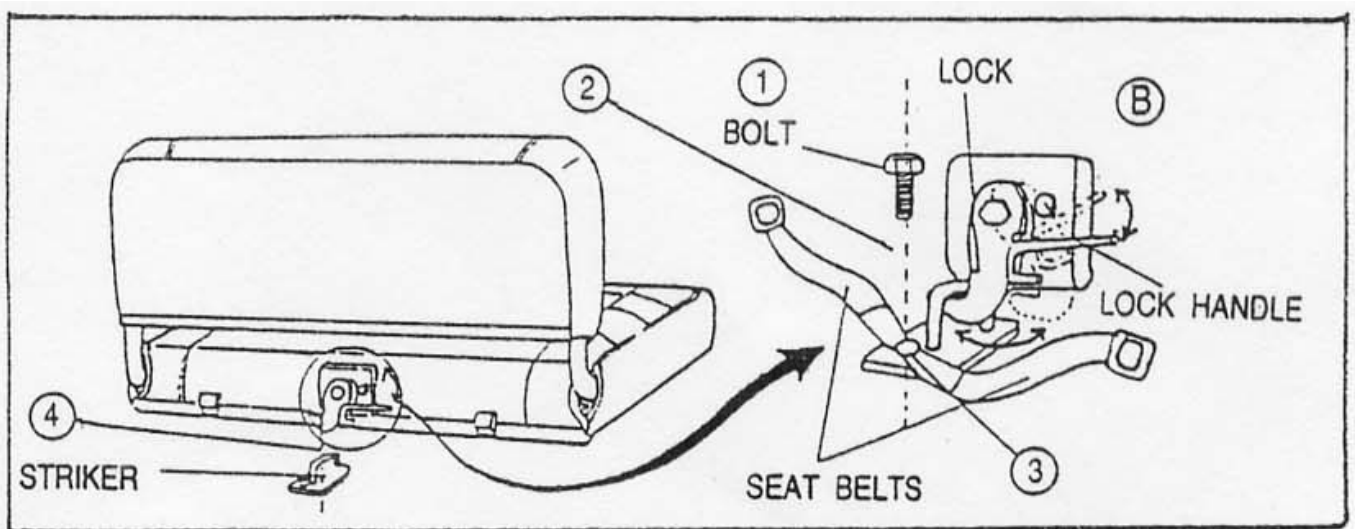

3. Reinstall seat belt anchor bolt through seat belt eyelets and seat lock. **DO NOT TIGHTEN YET.**
4. Align seat lock with striker so that seat locks when the seat is pushed down into position.
5. Tighten seat belt anchor bolt. At this time a second hole, if desired, can be drilled and additional hardware added (supplied by customer).

**For Technical Support/Warranty Information please call 310-762-9944**

**Smittybilt, 400 West Artesia Blvd, Compton, CA 90220**