

Raptor Series



Your satisfaction is important to us, please let us help!

If you have any questions or concerns during the installation, our support representatives are available to assist you.

Please call: 1-877-769-3765 or Live Chat at www.raptorseries.com

If you have damaged or missing parts please contact the company you purchased the product from and notify them of the issue right away.



CAUTION: Do not install damaged parts!!!

Raptor Series

Easy Return / Easy Exchange

Want to return an item or exchange? Not satisfied with purchase?

No problem. We strongly believe in service after the sale and we stand behind our products and our service to you, our valued customer. There is no problem we can't solve for you!

Items that have been installed and/or damaged after receipt, are no longer in new and ready-to-sell condition and cannot be refunded, replaced or exchanged unless it has a manufacturer defect or was damaged in shipping. In addition, we cannot accept return on items that are not in the original packaging. Items returned in poor condition or having parts missing will not be credited.

Please note: Your request for return or replacement must be initiated within 30 days of delivery of your merchandise.

Did your order arrive damaged?

Please do not install damaged products. Contact the company you purchased your product from as soon as possible and notify them of the damages. They will make arrangements with you to assist with the problem.

Did you order the wrong part or receive the wrong item?

Don't worry. From time to time human error can result in problems with ordering or shipping. Contact the company you purchased your product from as soon as you notice the error. Every company has their own policy on returning parts that have been ordered incorrectly or shipped incorrectly.

In the event that you need to ship your part back to return/exchange, please ship to the warehouse below:

**CYC Returns Warehouse
2415 Cathy Lane
Jasper, IN 47546**

The logo for Raptor Series features the word "Raptor" in a stylized, green, cursive font, with the word "Series" in a bold, black, sans-serif font directly below it. The background of the logo is a light green silhouette of a raptor in flight.

Raptor Series Warranty

LIMITED TEN (10) YEAR WARRANTY

For Powder Coated Steel Products

CYC Engineering, Inc. guarantees the original purchaser of our products a limited ten (10) year warranty from the date of original purchase against manufacturer defects in materials, workmanship and finish under normal use. The step pads are covered under warranty for 1 year. This warranty does not include damage resulting from road hazards such as gravel or other debris, product misuse, improper installation, impairments from accidents, product modifications, product neglect or scratches during the life of the product. This limited ten year warranty applies only to new products and is limited to the repair or replacement of company's products. Warranty does not include costs of removal, installation, labor, inconvenience or consequential damages. Original purchaser must return defective merchandise along with the purchase receipt, to the original place of purchase.

LIMITED LIFETIME WARRANTY



For Stainless Steel Products

CYC Engineering, Inc. guarantees the original purchaser of our products a limited lifetime warranty from the date of original purchase against manufacturer defects in materials, workmanship and finish under normal use. The step pads are covered under warranty for 1 year. This warranty does not include damage resulting from road hazards such as gravel or other debris, product misuse, improper installation, impairments from accidents, product modifications, product neglect or scratches during the life of the product. This limited lifetime warranty applies only to new products and is limited to the repair or replacement of company's products. Warranty does not include costs of removal, installation, labor, inconvenience or consequential damages. Original purchaser must return defective merchandise along with the purchase receipt, to the original place of purchase.

5" CURVED BAR

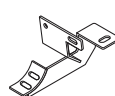
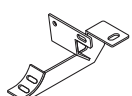

Components:

-  Driver & Passenger Side Step Bar
Qty 1
-  Passenger Front Mounting Bracket (Medium)
Qty 1
-  Passenger Center Mounting Bracket (Long)
Qty 1
-  Passenger Rear Mounting Bracket (Short)
Qty 1
-  Rubber Gasket
Qty 6

Hardware:

- | | |
|---|--|
|  M10 Nut Plate
Qty 6 |  M10 Flat Washer (30MM OD)
Qty 6 |
|  M10 x 25MM Hex Head Bolt
Qty 6 |  M10 Flat Washer (23MM OD)
Qty 12 |
|  M10 x 30MM Button Head Bolt
Qty 12 |  M10 Lock Washer
Qty 12 |
|  M6 Hex Head Nut
Qty 12 |  M6 Flat Washer
Qty 24 |
|  M8 Lock Washer
Qty 6 |  M6 x 25MM Button Head Bolt
Qty 12 |
|  M8 Flat Washer
Qty 6 |  M6 Lock Washer
Qty 12 |
|  M8 x 35MM Hex Head Bolt
Qty 6 | |

Tools Required:

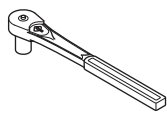

RATCHET

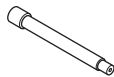

EXTENSION

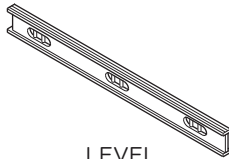

LEVEL



13MM SOCKET



10MM HEX BIT

Torque Specifications:

For Rocker Panel Mount Installations
M8 through M12 bolts and nuts are set to 15-20 ft lbs.

Note: When installing the brackets and bars, all hardware must be left loose until all the items are attached.

1. On passenger side of jeep, align Front, Center and Rear Brackets as shown.

Rev 5

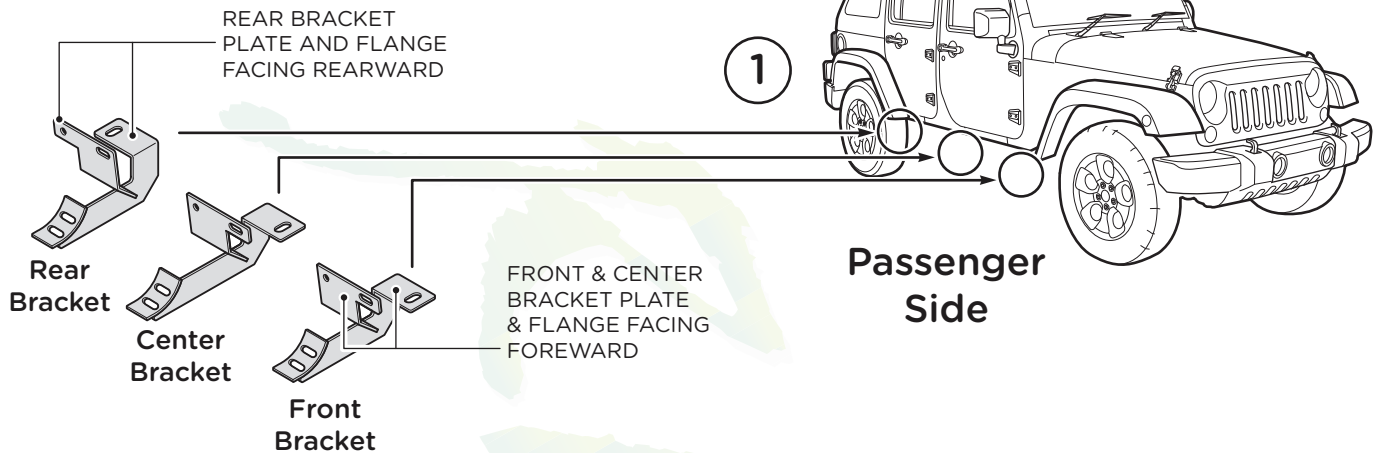

2. Starting on the passenger side front, locate the bracket mounting location on the underside of the Jeep body.

IF THE FRAME IS NOT PRE-THREADED

3. If the frame is not Pre-Threaded then you will install the brackets to the frame using the Non-Threaded Hardware Pack. Locate the square opening in the floor frame channel. Insert one (1) M10 Nut Plate into the opening. Next, fasten the bracket to the M10 Nut Plate using one (1) M10 x 25MM Hex Head Bolt, one (1) M10 Lock Washer and one (1) M10 Flat Washer.

Non-Threaded Hardware Pack

- M10 Nut Plate - Qty 6
- M10 x 25MM Hex Head Bolt - Qty 6
- M10 Flat Washer - Qty 6
- M10 Lock Washer - Qty 6

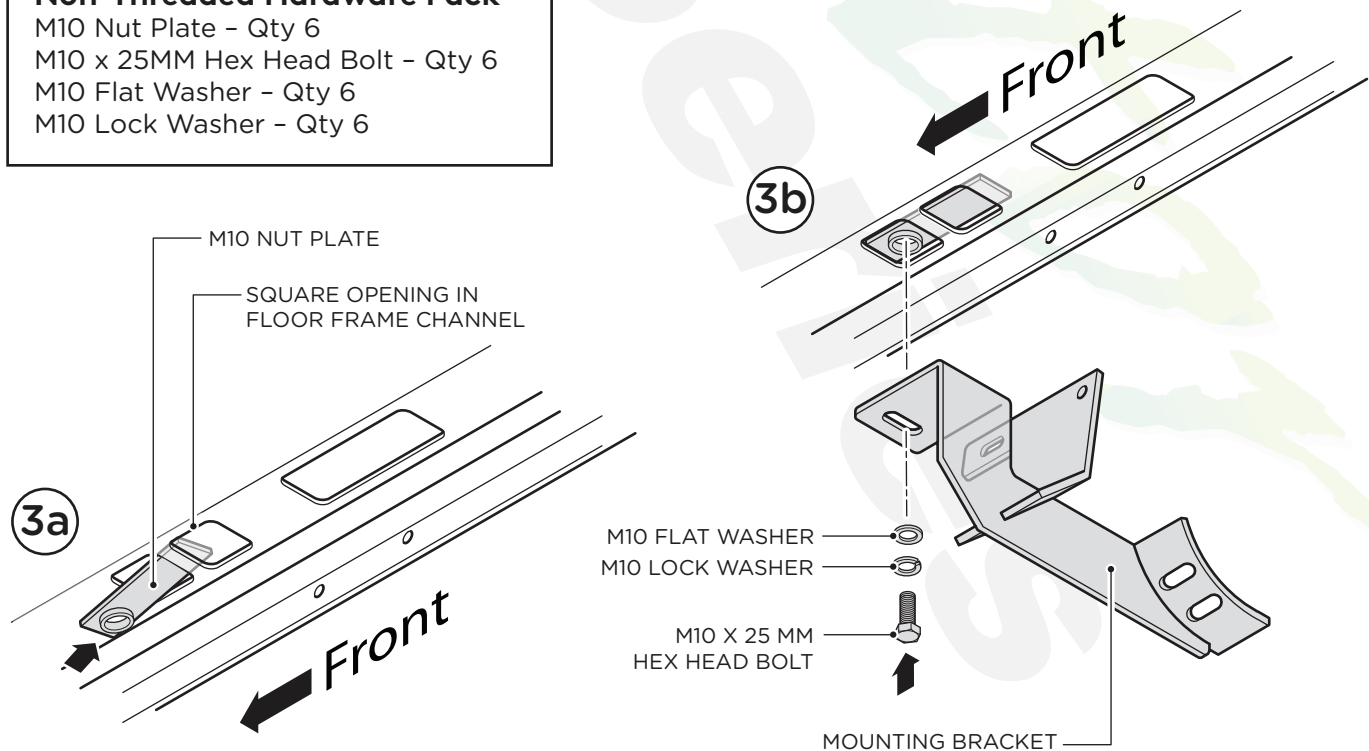

IF THE FRAME IS PRE-THREADED

4. If the frame is Pre-Threaded then you will install the brackets to the frame using the Pre-Threaded Hardware Pack. Start by fastening the bracket to the pre-threaded hole using one (1) M8 x 35MM Hex Head Bolt, one (1) M8 Lock Washer and one (1) M8 Flat Washer.

Pre-Threaded Hardware Pack

M8 x 35MM Hex Head Bolt - Qty 6

M8 Flat Washer - Qty 6

M8 Lock Washer - Qty 6

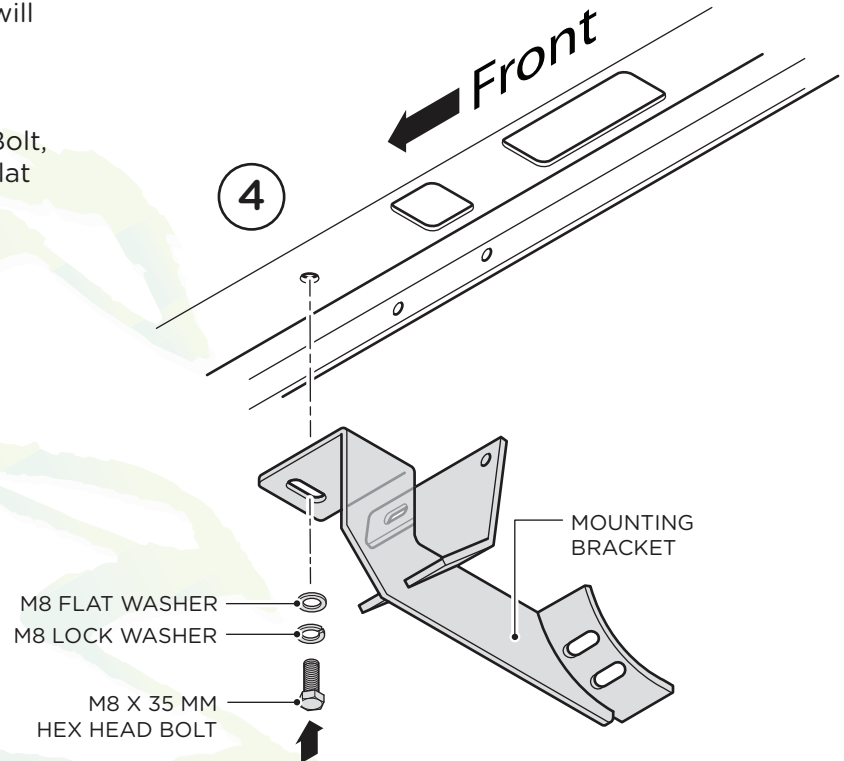

5. For both the Non-Threaded scenario and the Pre-Threaded scenario, attach the bracket to the pinch weld using two (2) M6 x 25MM Button Head Bolts, two (2) M6 Lock Washers and two (2) M6 Flat Washers.

Repeat this procedure for the remaining brackets.

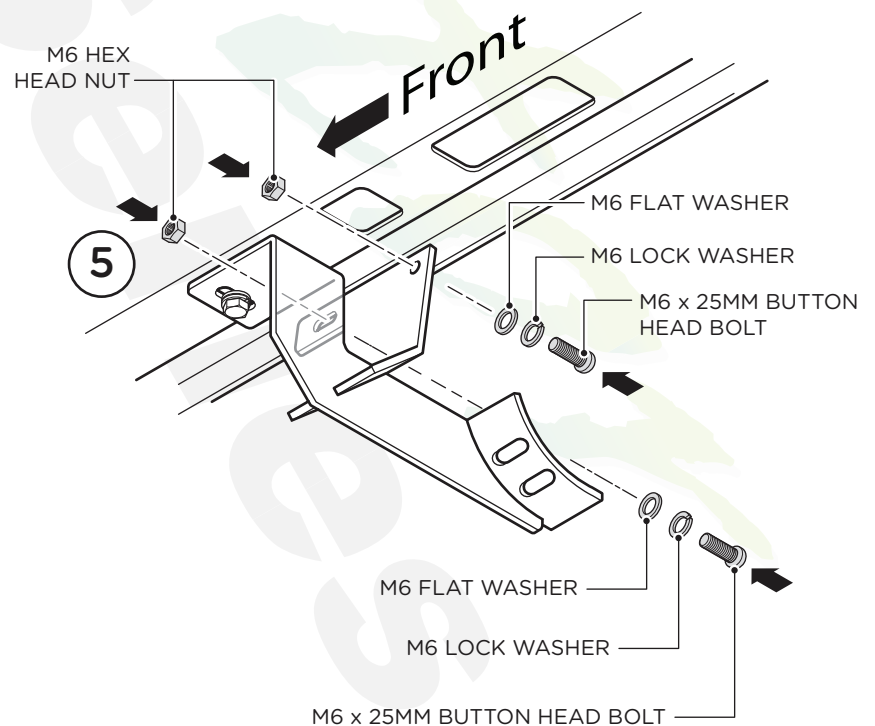

6. Place Step Bar and three (3) Rubber Gaskets onto Brackets.

7. Install Step Bar and Rubber Gasket onto each Bracket and attach using two (2) M10 Button Head Bolts, two (2) M10 Lock Washers and two (2) M10 Flat Washers per bracket.

Tighten until the split lock washer is flat against bracket and snug. DO NOT over tighten and strip the threaded insert in the tube.

Repeat these steps for driver side installation. When all hardware is in place, everything must be tightened. See Page 1 for Torque Specifications.

