

**STEP 1**

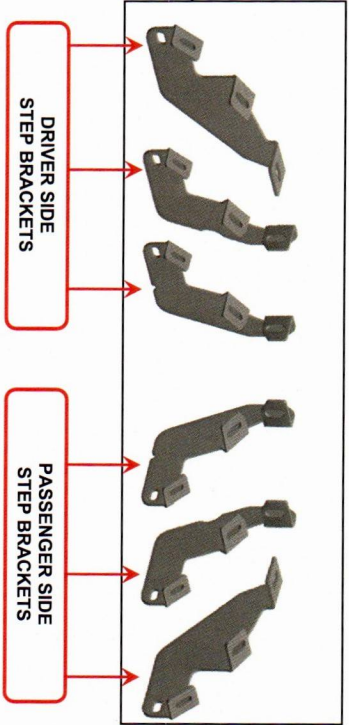

Please identify each mounting bracket using the engraved location identifier. **Notice:** Mounting Brackets look very similar but are unique.

DF: Driver Front  
DC: Driver Center  
DR: Driver Rear

PF: Passenger Front  
PC: Passenger Center  
PR: Passenger Rear

**STEP 2**

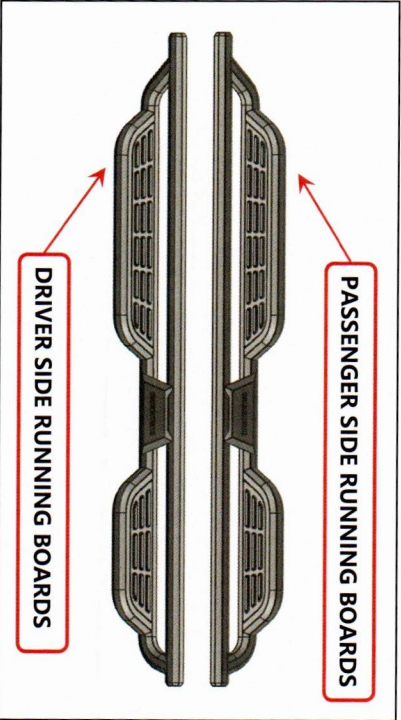

Identify each running board by identifier on the front. **Notice:** "D" for Driver/Left Side; "P" for Passenger/Right Side.

**STEP 3**

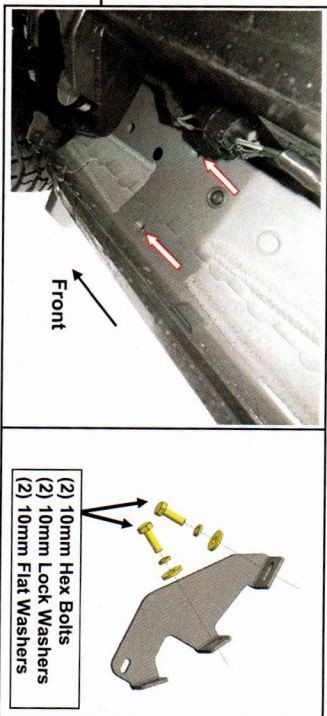

Start installation toward the front of the Passenger/Right side of the vehicle.

Loosely fit the (1) Passenger Front step bracket to the vehicle threaded body hole using (2) M10 x 30mm bolt, (2) M10 lock washer, and (2) M10 flat washer. Do not fully tighten to allow for later adjustments.

**STEP 4**

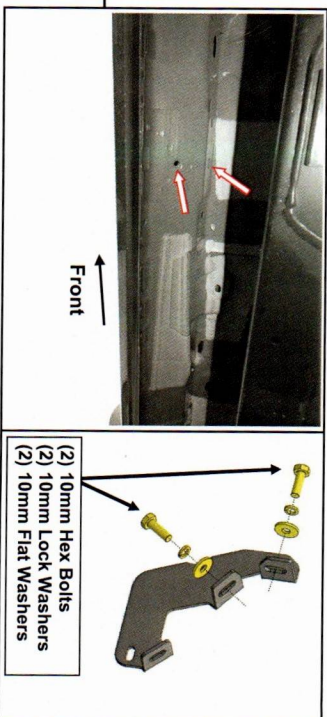

Loosely fit the (1) Passenger Center step bracket to the vehicle threaded body hole using (2) M10 x 30mm bolt, (2) M10 lock washer, and (2) M10 flat washer. Do not fully tighten to allow for later adjustments. Repeat this step for the Passenger Rear step brackets.

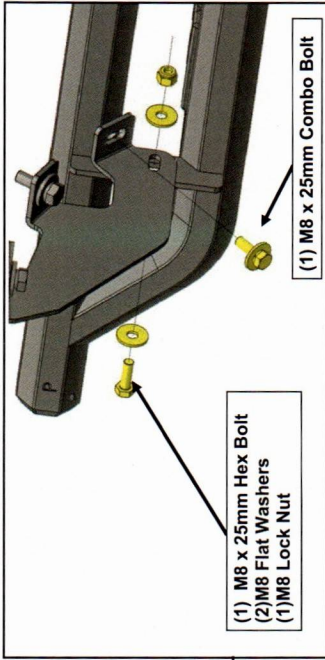
**STEP 5**

With all brackets loosely mounted to the vehicle, fit the running board onto the front bracket, and loosely secure into place using (1) M8 x 25mm combo bolt, (1) M8 x 25mm hex bolt, (2) M8 flat washer, (1) M8 lock nut. Repeat the step for other (2) PS step brackets.

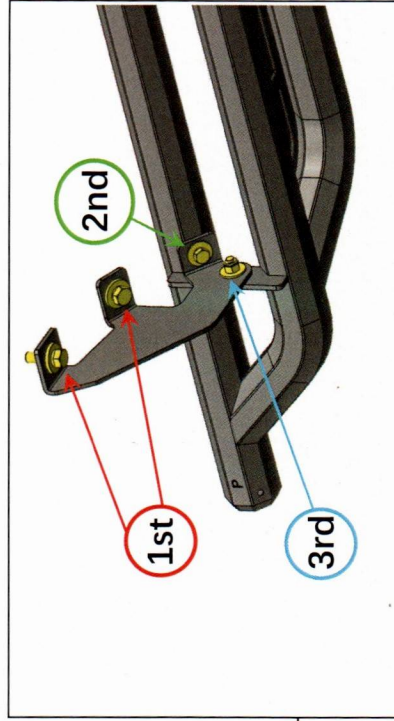
**STEP 6**

Tighten the mounting brackets to the vehicle. Adjust the running board to the desired angle, and tighten the bolts to secure the step into place. See photo for tightening order visual.

Repeat steps 1-6 for the remaining running board.  
Installation is now complete.



# TC4 HD RUNNING BOARDS

(2021-2025+ FORD BRONCO 4 DOOR)

## INSTALLATION INSTRUCTIONS

### CONTENTS

- (1) LH Running Board
- (1) RH Running Board
- (3) LH Step Brackets
- (3) RH Step Brackets
- (12) M10 x 30mm Hex Bolts
- (12) M10 x 27mm OD x 3mm Flat Washers
- (12) M10 Lock Washers
- (12) M8 x 24mm OD x 2mm Flat Washers
- (6) M8 x 25mm Combo Bolts
- (6) M8 x 25mm Hex Bolts
- (6) M8 Lock Nuts

### TOOLS REQUIRED

- 13mm/16mm
- Sockets/Wrenches
- Ratchet