

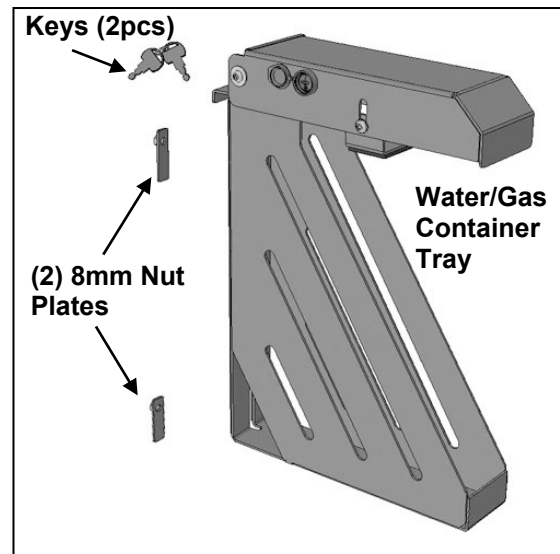

FB1 WATER/GAS CONTAINER TRAY
EQUIPPED WITH 37in MAX HD SPARE TIRE CARRIER
(COMPATIBLE WITH 2 GALLON ROTOPAX WATER/GAS CONTAINER)
2021-2023+ BRONCO – SKU # FB28234

PARTS LIST:

1	Water/Gas Container Tray
2	8-1.25mm Nut Plates
2	8-1.25mm x 25mm Button Head Bolts
2	8mm x 24mm x 2mm Flat Washers
2	8mm Lock Washers
1	Set of Lock Keys (2 pcs)
1	5mm Hex Wrench



PROCEDURE:

REMOVE CONTENTS FROM BOX. VERIFY ALL PARTS ARE PRESENT. READ INSTRUCTIONS CAREFULLY BEFORE STARTING INSTALLATION.

1. Carefully unwrap the Water/Gas Container Tray assembly.
2. Hang the Tray from the slot in the top of the tire mount, **(Figure 1)**.
3. Select (1) 8mm Nut Plate. Insert the Nut Plate up and into the slot in the tire mount, **(Figures 2 & 3)**. Line up the Nut Plate with the mounting holes in the Water/Gas Container Tray and tire mount. Attach the Water/Gas Container Tray to the Nut Plate in the tire carrier with the included (1) 8mm x 25mm Button Head Bolt, (1) 8mm Lock Washer and (1) 8mm Flat Washer, **(Figure 4)**. Leave loose.
4. Repeat **Step 3** to attach the bottom of the Tray to the lower leg on the tire mount, **(Figures 2, 4 & 5)**.
5. Align and adjust the Water/Gas Container Tray as necessary and fully tighten all mounting hardware.
6. Insert Water/Gas Container, (not included), into the Tray. Check fit between locking top latch and Water/Gas Container. Adjust height of inner Stop and tighten hardware, **(Figure 6)**.
7. Do periodic inspections to the installation to make sure that all hardware is secure and tight.

To protect your investment: Do not use any type of polish or wax that may contain abrasives that could damage the finish. Mild soap may be used to clean the Water/Gas Container Tray assembly.

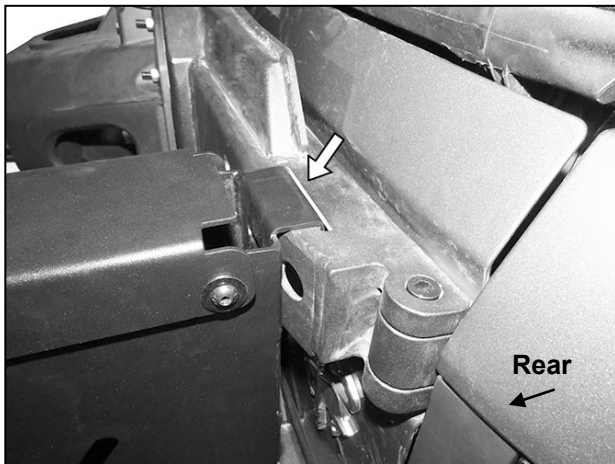

(Fig 1) Hang Water/Gas Container Tray from slot in top of tire mount

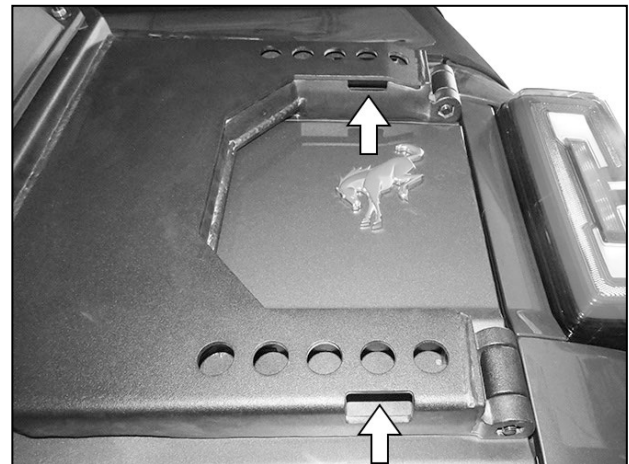

(Fig 2) Insert 8mm Nut Plates up into slots (arrows)

FB1 WATER/GAS CONTAINER TRAY
EQUIPPED WITH 37in MAX HD SPARE TIRE CARRIER
(COMPATIBLE WITH 2 GALLON ROTOPAX WATER/GAS CONTAINER)
2021-2023+ BRONCO – SKU # FB28234

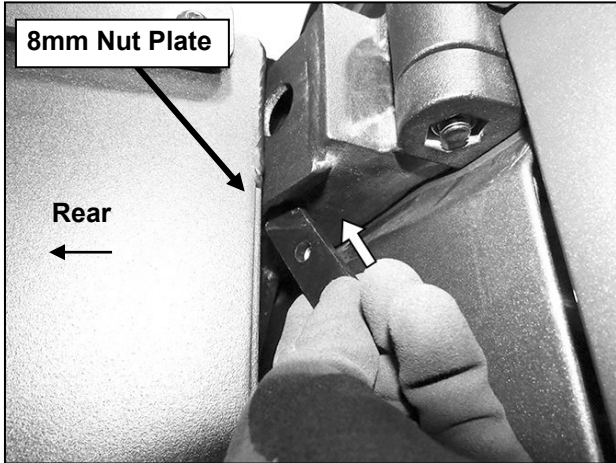

(Fig 3) Insert Nut Plate up and into top leg on Tire Mount

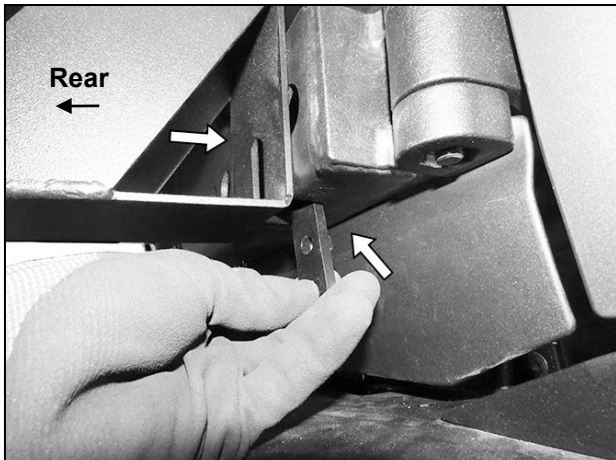

(Fig 5) Insert Nut Plate up into bottom leg on tire mount. Attach bottom of Water/Gas Container Tray to Nut Plate in tire mount (see Fig 4)



Complete Installation
(Water/Gas Container not included)

- (2) 8mm x 25mm Button Head Bolts
- (2) 8mm Lock Washers
- (2) 8mm Flat Washers

- (2) 8mm Nut Plates

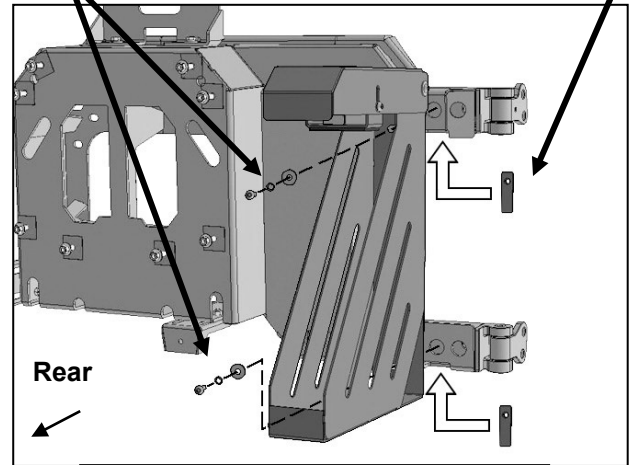

(Fig 4) Attach Water/Gas Container Tray to Nut Plates in tire mount

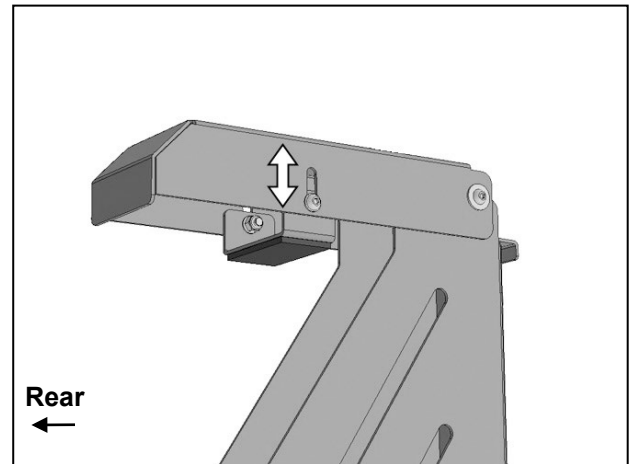

(Fig 6) Insert Water/Gas Container into the Tray. Adjust inner stop up or down to fit against Water/Gas Container and tighten hardware