

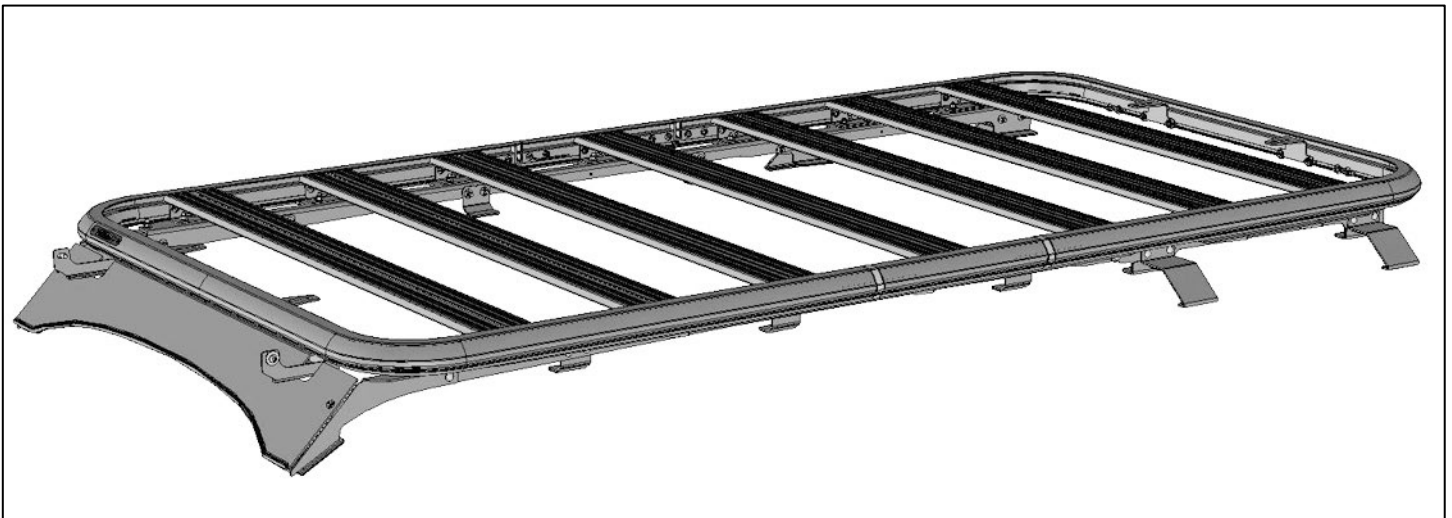

**PR-1 PLATFORM RACK
2021-22 FORD BRONCO 4-DOOR
EXCLUDES MODELS WITH SOFT TOP**

PARTS LIST: FB17169

1	Front Wind Fairing	(A)	4	2-Hole Rear Bracket Spacer Plates	(P)
1	Rubber Edge Trim for Fairing	(B)	2	Forward Outer Clamping Brackets	(Q)
2	Front/rear Platform Assemblies	(C)	2	Rear Outer Clamping Brackets	(R)
2	Center Platform End Rails	(D)	1	Driver/left Front Light Bracket	(S)
2	End Rail "C" Channel Brackets	(E)	1	Passenger/right Front Light Bracket	(T)
1	Center Cross Rail	(F)	4	Accessory/Light brackets	(U)
4	Molded Platform Connectors	(G)	14	6mm x 25mm Double Bolt Plates	(V)
1	Driver/left Front Side Rail Mount	(H)	2	8-1.25 x 16mm Button Head Bolts	
1	Passenger/right Front Side Rail Mount	(I)	2	8mm x 24mm x 2mm Large Flat Washers	
1	Driver/left Center Side Rail	(J)	2	8mm Lock Washers	
1	Passenger/right Center Side Rail	(K)	4	6mm x 20mm T-Bolts	
1	Driver/left Rear Side Rail Mount	(L)	28	6mm x 25mm Carriage Bolts	
1	Passenger/right Rear Side Rail Mount	(M)	22	6-1.0 x 25mm Button Head Combo Bolts	
2	Front Side Rail Bracket Spacers	(N)	60	6mm x 18mm x 1.6mm Flat Washers	
6	Center Support "L" Brackets	(O)	56	6mm Nylon Lock Nuts	
6	Center Support Square Foam Pads		10	6-1.0mm Flange Nuts	
4	Rear Medium Rectangular Foam Pads		1	5mm Wrench	
4	Rear Clamp Bracket Foam Pads		1	4mm Wrench	



**PR-1 PLATFORM RACK
2021-22 FORD BRONCO 4-DOOR
EXCLUDES MODELS WITH SOFT TOP**

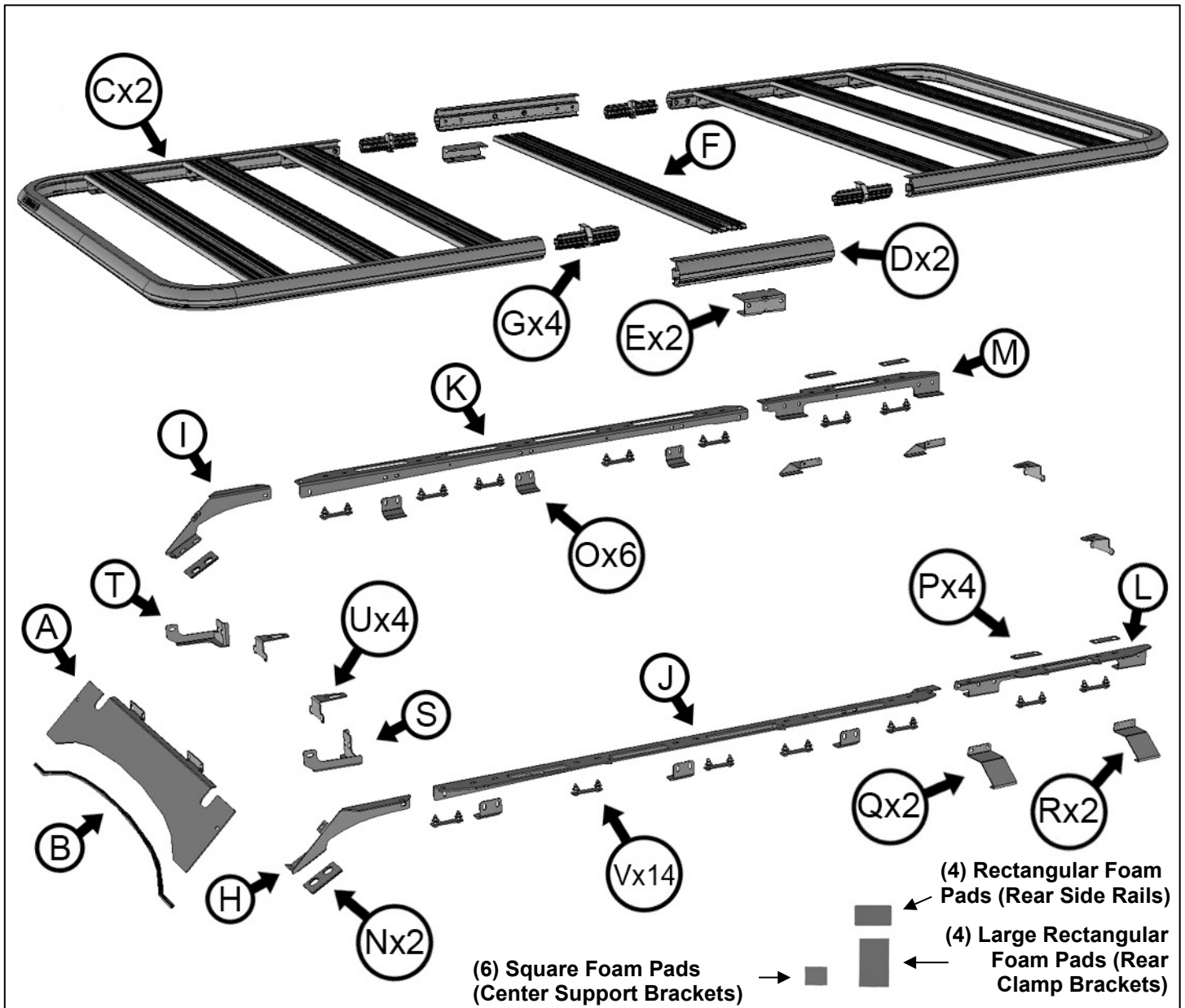

PROCEDURE:

REMOVE CONTENTS FROM BOX. VERIFY ALL PARTS ARE PRESENT. READ INSTRUCTIONS CAREFULLY. ASSISTANCE IS REQUIRED. MODELS WITH FACTORY ROOF RACK, COMPLETE ROOF RACK MUST BE REMOVED.

1. Remove the plastic cover over the accessory mounting location, **(Figure 1)**. Remove the inner clip, **(Figure 2)**.
2. Select (1) Front Side Rail Bracket Spacer, **(Figure 3)**, Slide the Spacer over the driver/left side mounting studs. Repeat **Steps** to remove the passenger/right side cover and attach the Spacer.
3. Select the driver/left Front Side Panel Bracket and driver/left Center Side Panel, **(Figure 4)**. Attach the Front Side Panel Bracket to the Center Panel with the included (2) 6mm Carriage Bolts, (2) 6mm Flat Washers and (2) 6mm Nylon Lock Nuts. Snug but do not fully tighten hardware.
4. Next, select (3) Center Support "L" Brackets and (3) Small Square Adhesive Backed Foam Pads, **(Figure 5)**. Remove the backing on the Foam Pads and apply the Pads to the bottom of the "L" Support Brackets, **(Figure 6)**.

**PR-1 PLATFORM RACK
2021-22 FORD BRONCO 4-DOOR
EXCLUDES MODELS WITH SOFT TOP**

5. Attach the “L” Support Brackets to the back of the Center Side Rail with the included (6) 6mm Carriage Bolts, (6) 6mm Flat Washers and (6) 6mm Nylon Lock Nuts, **(Figure 6 & 7)**. Leave hardware loose.
6. Select the driver/left Rear Side Panel, **(Figure 8)**. Attach the Rear Side Panel to the Center Panel with the included (2) 6mm Carriage Bolts, (2) 6mm Flat Washers and (2) 6mm Nylon Lock Nuts. Snug but do not fully tighten hardware.
7. Select (2) Medium Rectangular Adhesive Backed Foam Pads, **(Figure 5)**. Remove the backing on the Foam Pads and apply the Pads to the bottom of the support base on the Rear Side Rail, **(Figure 8)**.
8. Select the Front Outer Clamp Bracket and (1) Large Rectangular Adhesive Backed Foam Pad, **(Figures 5 & 9)**. Apply the Foam Pad to the inside of the Outer Clamp, **(Figure 10)**. Attach the Outer Clamp to the front mounting holes in the Rear Side Rail with (2) 6mm Carriage Bolts, (2) 6mm Flat Washers and (2) 6mm Nylon Lock Nuts. Leave hardware loose.
9. Select the Rear Outer Clamp Bracket and (1) Large Rectangular Adhesive Backed Foam Pad, **(Figure 9)**. Apply the Foam Pad to the inside of the Outer Clamp. Attach the Outer Clamp to the rear mounting holes in the Rear Side Rail with (2) 6mm Carriage Bolts, (2) 6mm Flat Washers and (2) 6mm Nylon Lock Nuts, **(Figure 11)**. Leave hardware loose. The driver/left Side Rail is assembled, **(Figure 12)**.
10. Repeat **Steps 3—9** to assemble the passenger/right Side Rail.
11. Next, select (1) “C” Channel Bracket and (1) Center Platform Connector, **(Figure 13)**. Attach the “C” Channel to the threaded holes on the inside of the Center Connector with the included (2) 6mm Button Head Combo Bolts. Tighten Bolts attaching “C” Channel to Connector only at this time. Repeat this **Step** to attach the remaining “C” Channel to the other Connector Rail.
12. Next, select the Center Platform Cross Panel. Slide (2) 6mm “T” Bolts into the channels in the end of the Panel, **(Figure 14)**. Attach the Panel and “T” Bolts to the top of the (1) Platform Connector “C” Channel Bracket with the included (2) 6mm Flat Washers and (2) 6mm Nylon Lock Nuts. Repeat this **Step** to attach the remaining Connector to the other end of the Center Panel.
13. Carefully unwrap (1) Platform Panel End Assembly. Slide (2) Molded Connectors into the open ends on the Platform Assembly, **(Figure 15)**. Slide the Center Platform Assembly over the Molded Connectors, **(Figure 16)**. Secure the End and Center Platforms to the Molded Connectors with (8) 6mm Combo Bolts. Push Panels all the way in against the Connectors and fully tighten hardware.
14. Repeat **Step 13** to insert the remaining (2) Molded Connectors into the open ends on the 2nd Platform Assembly, **(Figure 16)**. Slide the 2nd Platform Assembly into the Main Platform Assembly. Secure the 2nd Platform to the Assembly with (8) 6mm Combo Bolts. Push Panel all the way in against the Connectors and fully tighten hardware.
15. Carefully place the Platform Assembly onto the driver/left Side Rail Assembly. Locate the (5) attachment points along the top of the Side Rail Assembly, **(Figure 17)**. Align the “C” Channel Brackets on the inside of the Platform with the (7) mounting locations.
16. Select (1) 6mm Double Bolt Plate. Insert the Bolt Plate up from the outside of the front mounting holes in the Side Rail and through the (2) mounting holes on the Platform, **(Figure 17)**. Secure the Platform to the Bolt Plate and Side Rail with (2) 6mm Flat Washers and (2) 6mm Nylon Lock Nuts. Leave hardware loose at this time. Repeat this **Step** to insert (4) 6mm Double Bolt Plates through the #2 — #5 mounting locations along the center of the Side Rail, **(Figures 17 & 18)**.
17. Next, select (1) 2-hole Spacer Plate. Move to the #6 mounting location on the Rear Side Rail. Insert the Spacer Plate between the top of the Side Rail and the “C” Channel on the Platform, **(Figure 19)**. Secure the Platform to the Bolt Plate with (2) 6mm Flat Washers and (2) 6mm Nylon Lock Nuts. Leave hardware loose at this time. Repeat this **Step** to insert (1) Spacer Plate between the top of the last mounting location, (#7), on the Side Rail and the “C” Channel on the Platform, **(Figure 19)**. Secure the Platform and Spacer to the Bolt Plate with (2) 6mm Flat Washers and (2) 6mm Nylon Lock Nuts. Do not fully tighten hardware at this time.
18. Repeat **Steps 15—17** to attach the passenger/right side of the Platform to the passenger/right Side Rail Assembly.
19. With assistance, carefully lift the complete Platform assembly up and onto the vehicle. Do not slide the Platform on the roof of the vehicle to prevent damage to the finish.
20. Attach the front end of both Side Rails to the threaded studs and previously installed Bracket Spacers with the included (4) 6mm Flange Nuts or reuse the factory flange nuts, **(Figures 20 & 21)**.

**PR-1 PLATFORM RACK
2021-22 FORD BRONCO 4-DOOR
EXCLUDES MODELS WITH SOFT TOP**

21. Move to the driver/left rear of the Platform Assembly. Hook the end of the (2) Outer Clamp Brackets into the slots above the rear side window, **(Figure 22)**. Repeat this **Step** to attach the passenger/right Outer Clamping Brackets.
22. Adjust the (6) "L" Center Support Brackets up or down as necessary to properly level and support the center of the Platform assembly and fully tighten Support Bracket hardware only, **(Figure 23)**.
23. Next, select the Front Wind Fairing and Edge Trim. Push the Edge Trim onto the forward edge of the Fairing, **(Figure 24)**.
24. Remove the (4) 6mm Flange Nuts and Washers from the (4) preinstalled inner 6mm T-Bolts, **(Figure 25)**. Reuse the Flange Nuts and Washers to attach the bent end of the Wind Fairing to the T-Bolts on the inside of the Platform. Attach the front of the Fairing to the tabs on the end of the Siderails with (2) 6mm Button Head Combo Bolts and (2) 6mm Flange Nuts, **(Figure 26)**. Align the Fairing to the Platform and Side Rails. **NOTE:** An extra (2) T-Bolts have been preinstalled in each Platform section for customer use as needed.
25. Check the Platform assembly for alignment, adjust as necessary and fully tighten all hardware.
26. Determine if included light brackets will be installed (optional-lights not included).

Bar style LED Light Brackets (install through Wind Fairing).

- a. Remove the (2) 6mm Flange Nuts and Washers from the (2) preinstalled outer 6mm T-Bolts, **(Figure 27)**. Select the driver/left Front Light Bracket. Insert the Bracket through the back of the opening in the Wind Fairing, **(Figure 28)**. Reuse the Flange Nuts and Washers to attach the inner end of the Bracket to the T-Bolts. Repeat this **Step** to attach the passenger/right Light Bracket.
- b. Attach light to the Brackets with the included (2) 8mm x 16mm Button Head Bolts, (2) 8mm Lock Washers and (2) 8mm Flat Washers, **(Figure 28)**.

Accessory or Light Brackets.

- a. Remove the (4) 6mm Flange Nuts and Washers attaching the Wind Fairing to the inner 6mm T-Bolts, **(Figure 29)**. Reuse the Flange Nuts and Washers to attach the Accessory Bracket to the T-Bolts and over the tabs on the Fairing.
 - b. Repeat previous **Step** to attach the rear Accessory/Light Brackets as desired, **(Figure 30)**.
27. Do periodic inspections to the installation to make sure that all hardware is secure and tight.

To protect your investment, Do not use any type of polish or wax that may contain abrasives that could damage the finish. Mild soap may be used to clean the Roof Rack.

Driver/left Side Installation Pictured



(Fig 1) Remove cover and inner clip

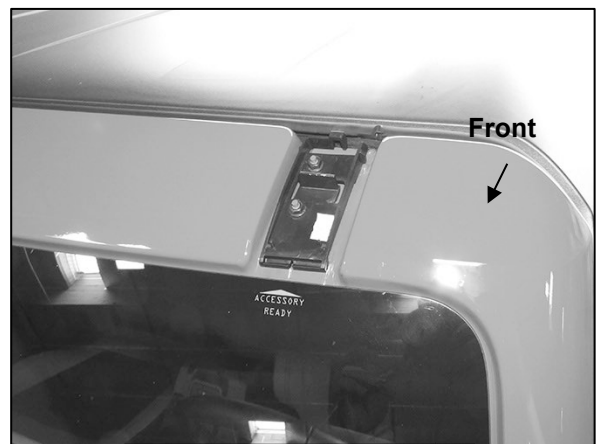

(Fig 2) Remove inner clip

**PR-1 PLATFORM RACK
2021-22 FORD BRONCO 4-DOOR
EXCLUDES MODELS WITH SOFT TOP**

Driver/left Side Installation Pictured

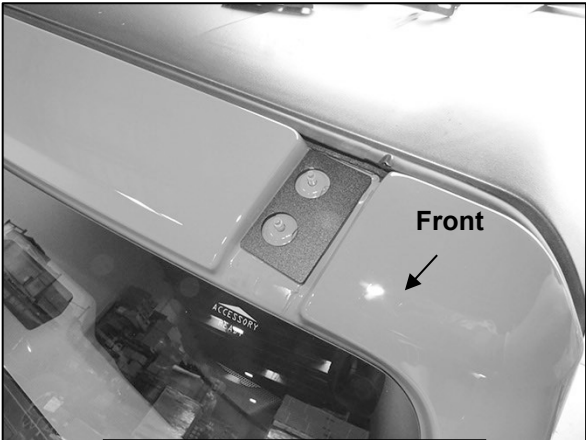

(Fig 3) Place Bracket Spacer over threaded studs

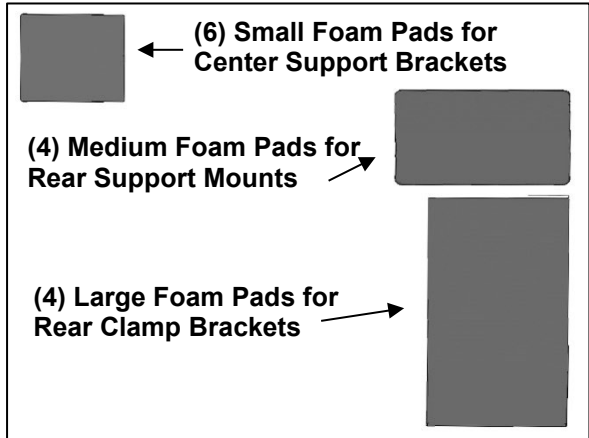

(Fig 5) Adhesive Backed Foam Pad identification illustration

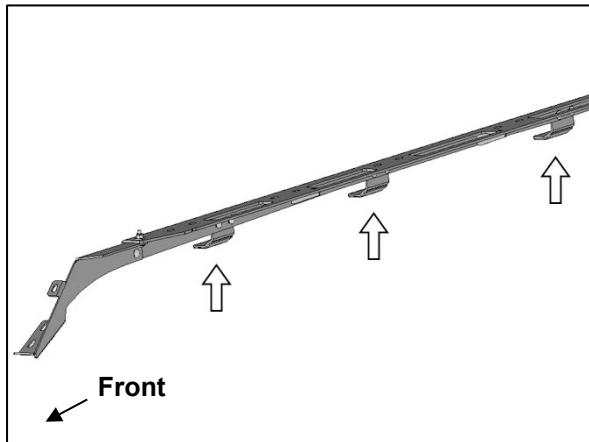

(Fig 7) Attach (3) "L" Support Brackets to the back of the driver/left Center Rail

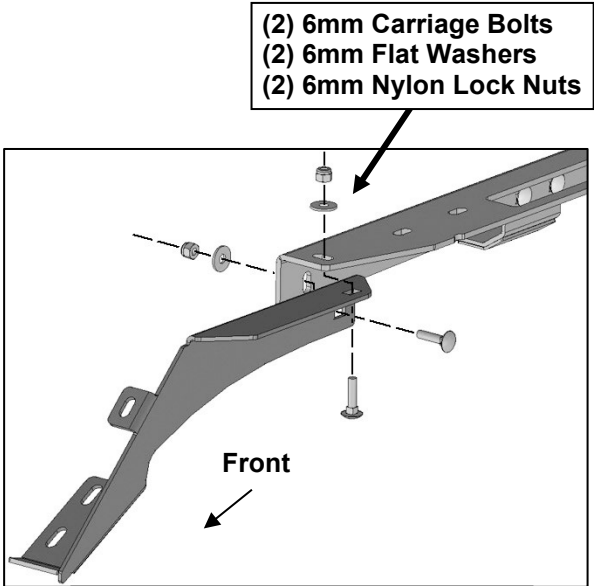

(Fig 4) Attach driver/left front Side Rail Mount to Center Side Rail

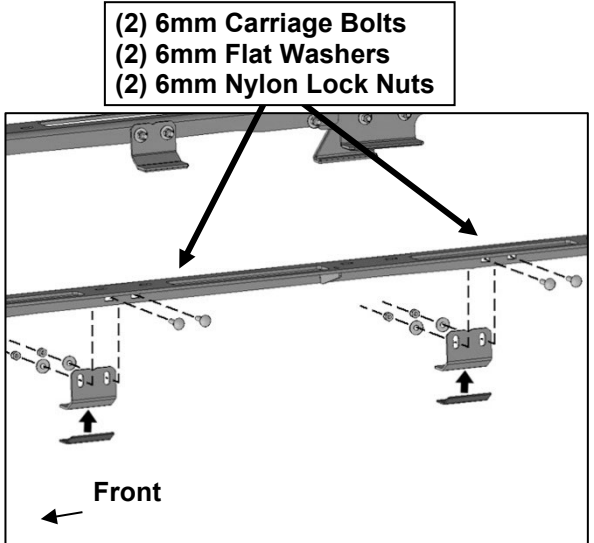

(Fig 6) Attach (3) "L" Support Brackets to the back of the driver/left Center Rail. Apply Adhesive Backed Foam Pads to bottom of Support Brackets

**PR-1 PLATFORM RACK
2021-22 FORD BRONCO 4-DOOR
EXCLUDES MODELS WITH SOFT TOP**

Driver/left Side Installation Pictured

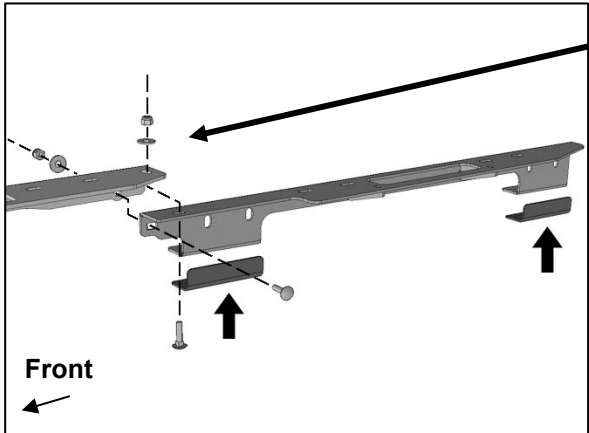

- (2) 6mm Carriage Bolts
- (2) 6mm Flat Washers
- (2) 6mm Nylon Lock Nuts

(Fig 8) Attach driver/left Rear Side Rail to Center Rail. Apply Adhesive Backed Medium Foam Pads to bottom of Side Rail Mounts

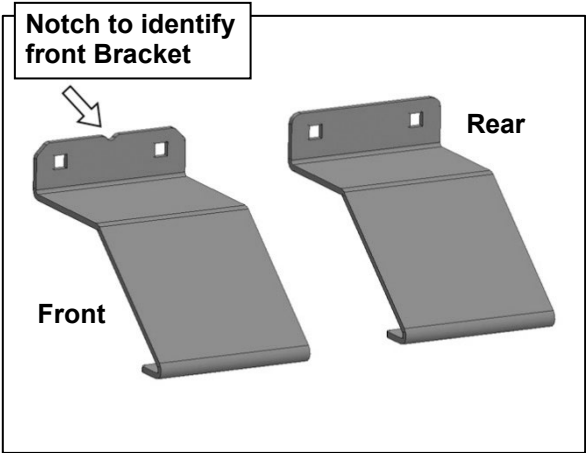

Notch to identify front Bracket

(Fig 9) Select (1) Front Clamping Bracket. Apply Adhesive Backed Large Foam Pad to inside of Clamping Bracket

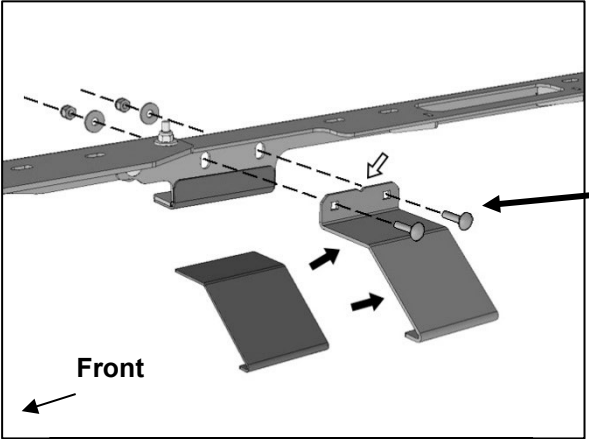

- (2) 6mm Carriage Bolts
- (2) 6mm Flat Washers
- (2) 6mm Nylon Lock Nuts

(Fig 10) Attach Front Clamping Bracket to outside of Rear Side Rail

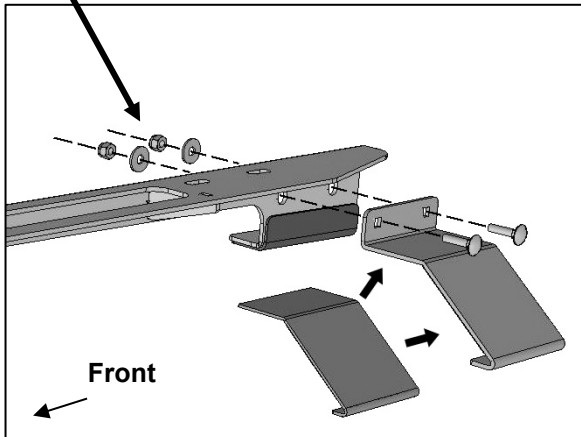

(Fig 11) Attach Rear Clamping Bracket to outside of Rear Side Rail. Apply Adhesive Backed Large Foam Pad to inside of Clamping Bracket

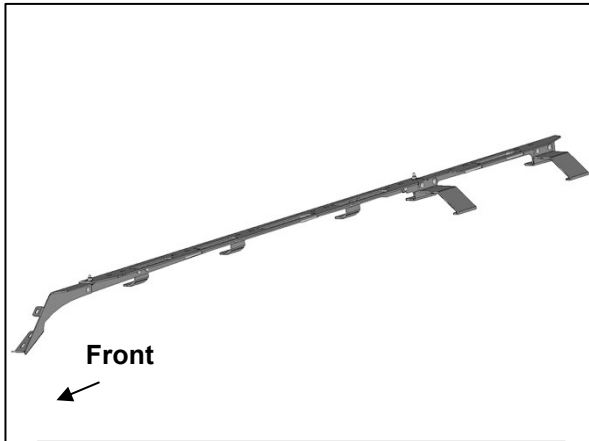

(Fig 12) Driver/left Side Rail assembled

**PR-1 PLATFORM RACK
2021-22 FORD BRONCO 4-DOOR
EXCLUDES MODELS WITH SOFT TOP**

Driver/left Side Installation Pictured

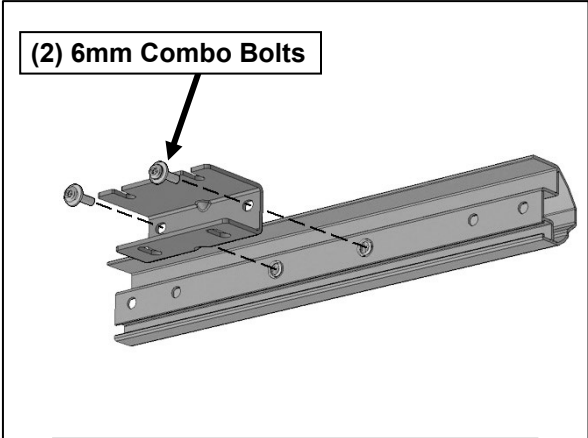

(Fig 13) Attach "C" Bracket to inside of Center Platform End Rail

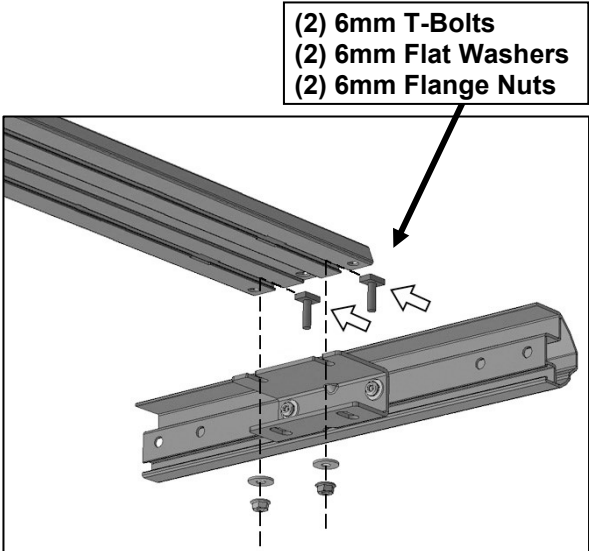

(Fig 14) Insert (2) T-Bolts into channels in end of Cross Rail. Attach Cross Rail to top of "C" Bracket

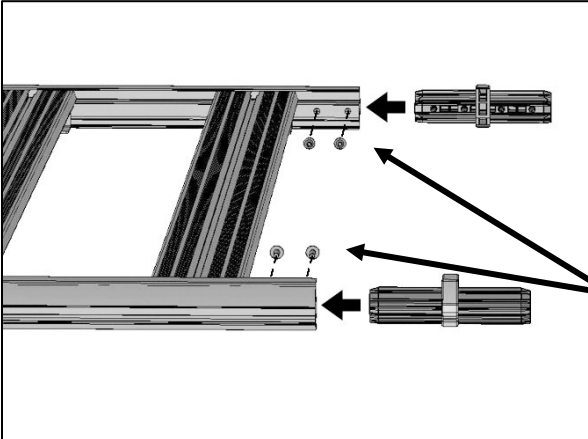

(Fig 15) Insert Molded Connectors into the end of (1) outer Platform Assembly

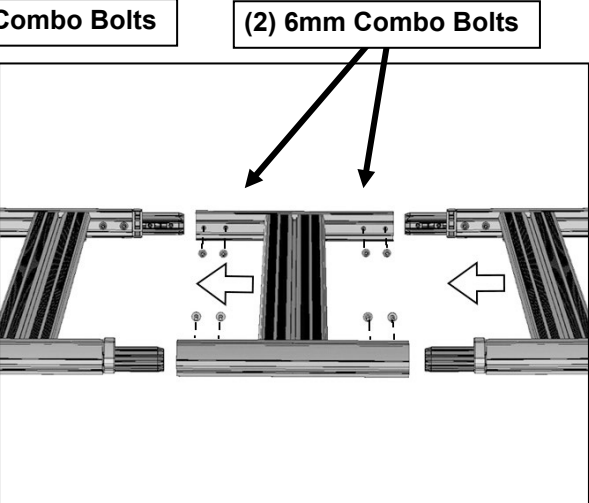

(Fig 16) Attach Center Panel Assembly and remaining Platform Assembly to first Panel Assembly

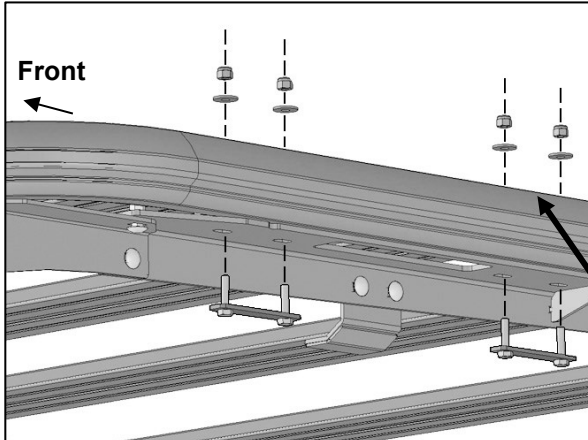

(Fig 17) Insert Double Bolt Plates up through holes in Side Rails. Attach Platform to Bolt Plates (front and #2 locations illustrated)

**PR-1 PLATFORM RACK
2021-22 FORD BRONCO 4-DOOR
EXCLUDES MODELS WITH SOFT TOP**

Driver/left Side Installation Pictured

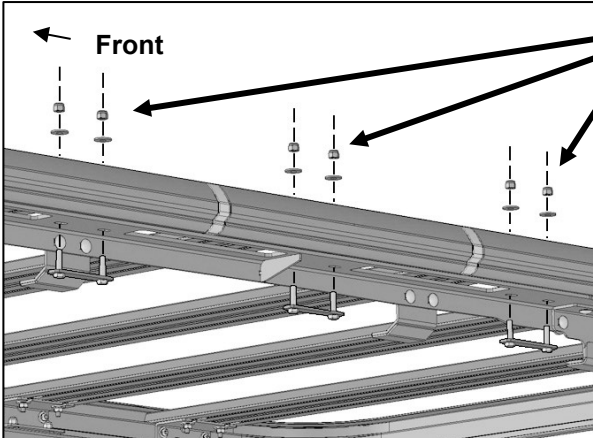

**(2) 6mm Flat Washers
(2) 6mm Nylon Lock Nuts**

(Fig 18) Insert Double Bolt Plates up through holes in Side Rails. Attach Platform to Bolt Plates (#3, #4 and #5 locations illustrated)

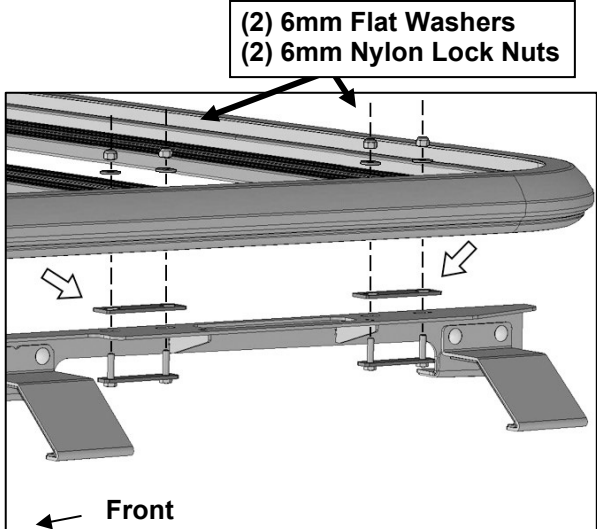

**(2) 6mm Flat Washers
(2) 6mm Nylon Lock Nuts**

(Fig 19) Insert Spacer Plates (arrows) between Platform and Rear Side Rail. Insert Double Bolt Plates up through holes in Side Rails, Spacers and into Platform

(2) 6mm Flange Nuts

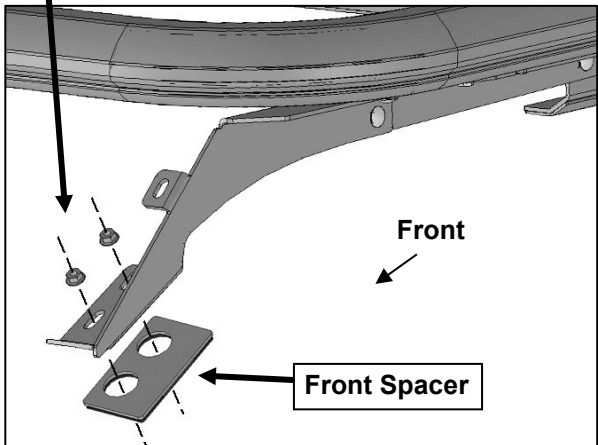

(Fig 20) Carefully place Platform assembly onto vehicle. Attach front mounts to threaded studs and Spacers above front windshield



(Fig 21) Attach front mounts to threaded studs and Spacers above front windshield

**PR-1 PLATFORM RACK
2021-22 FORD BRONCO 4-DOOR
EXCLUDES MODELS WITH SOFT TOP**

Driver/left Side Installation Pictured



(Fig 22) Hook Outer Clamp Brackets into slots above rear side windows

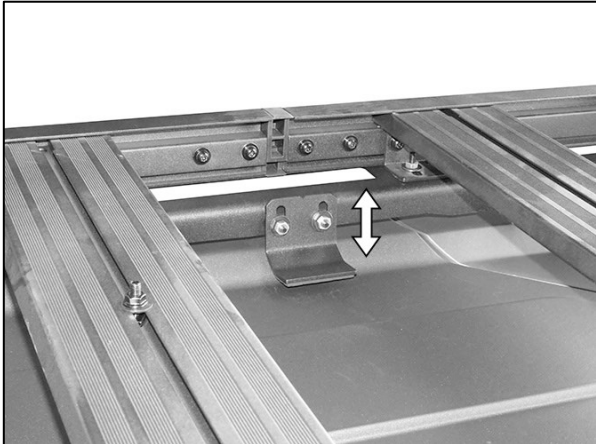

(Fig 23) Adjust Support Brackets up or down to press against top of roof to level Platform

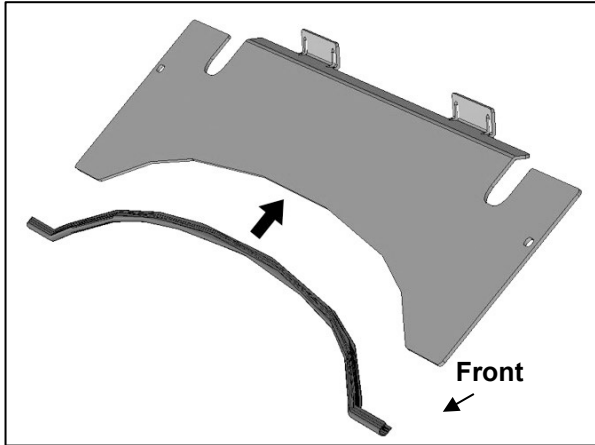

(Fig 24) Press Edge Trim onto Wind Fairing

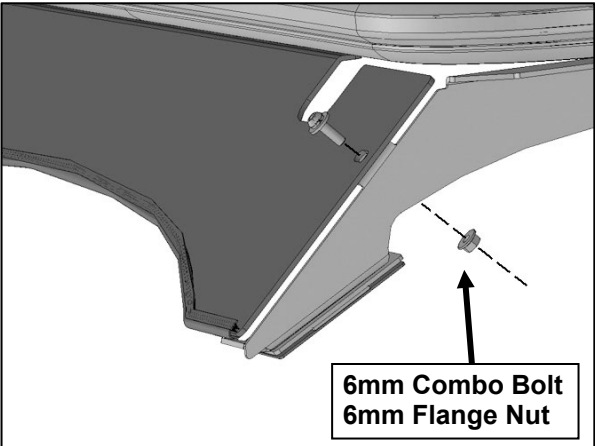

(Fig 26) Attach sides of Fairing to tabs on top of Front Rails

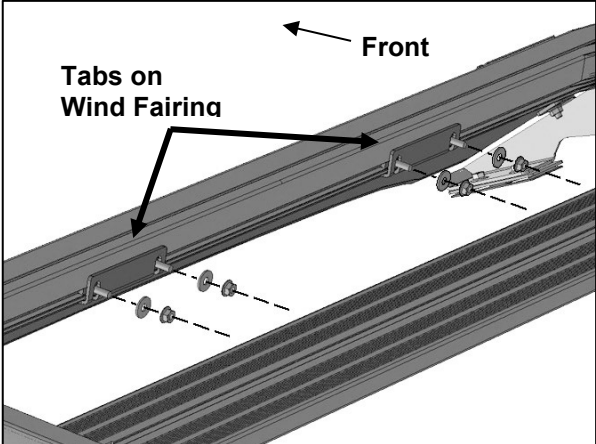

(Fig 25) Reuse preinstalled hardware to attach mounting tabs on top of Wind Fairing to inside and back of Platform assembly. NOTE: An extra (2) T-Bolts have been preinstalled in each Platform section for customer use as needed.

**PR-1 PLATFORM RACK
2021-22 FORD BRONCO 4-DOOR
EXCLUDES MODELS WITH SOFT TOP**

Driver/left Side Installation Pictured

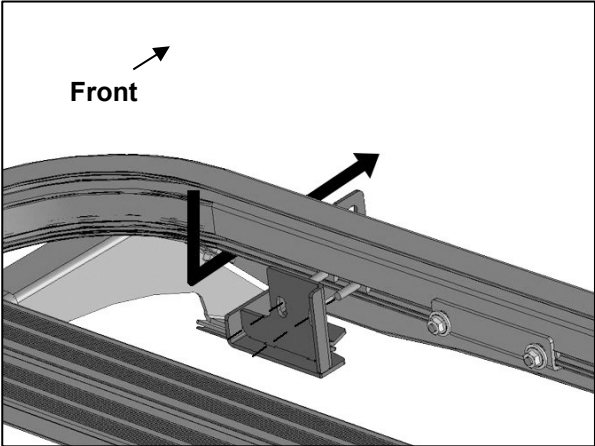

(Fig 27) Insert driver/left Light Bracket through back of Fairing

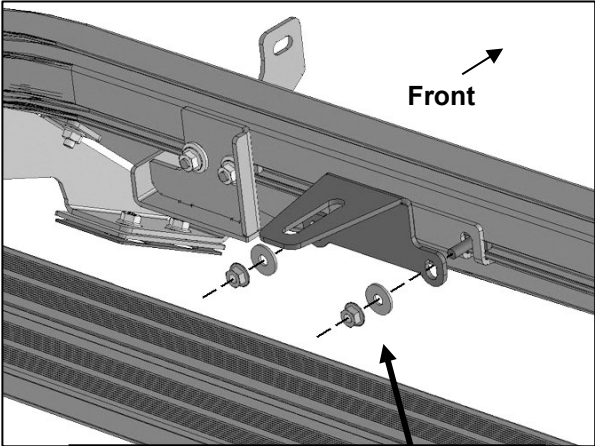

(Fig 29) Reuse hardware to attach Accessory/Light Bracket to back of Fairing (installation optional)



Complete Installation

- 8mm x 16mm Button Head Bolt
- 8mm Lock Washer
- 8mm Flat Washers

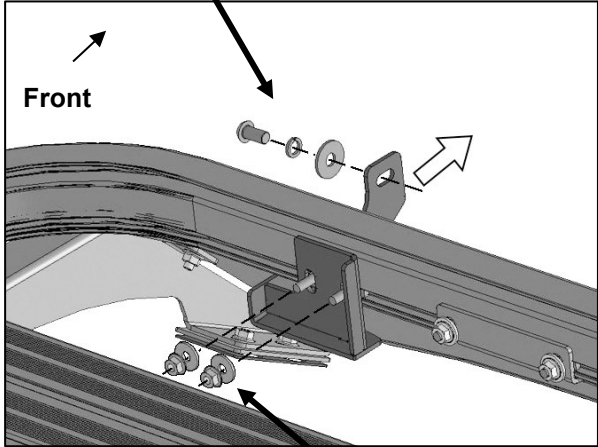

(Fig 28) Reuse preinstalled hardware to attach Light Bracket to inside and back of Platform assembly

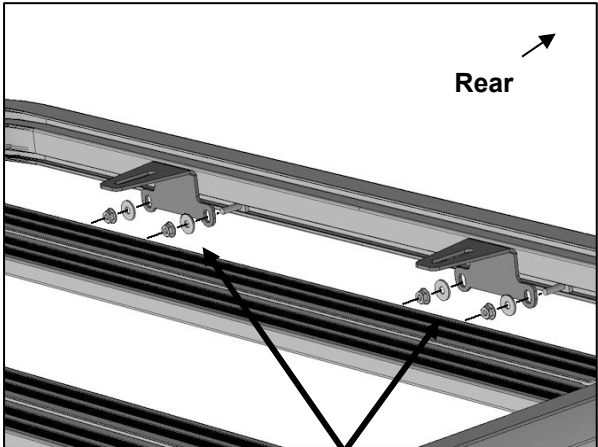

(Fig 30) Reuse preinstalled hardware to attach Light Brackets to inside and back of rear Platform assembly (installation optional). NOTE: An extra (2) T-Bolts (not shown) have been preinstalled in each Platform section for customer use as needed.