



---

# TRAIL FORCE HD FRONT BUMPER

(2021-2023+ BRONCO)

---

## INSTALLATION INSTRUCTIONS

### CONTENTS

---

- (6) M12 x 1.75 x 50mm Hex Bolts
- (6) M12 Lock Washers
- (6) M12 Flat Washers
- (8) M8 x 1.25 x 25mm Allen Bolts
- (16) M8 Flat Washers
- (8) M8 Flange Nuts
- (3) M6 x 1.00 x 30mm Allen Bolts
- (8) M6 x 1.00 x 20mm Hex Bolts
- (22) M6 Flat Washers
- (11) M6 Lock Washers
- (11) M6 Flange Nuts
- (8) Phillips Screws
- (4) Backup Sensor Kits
- (1) LH Nut Plate
- (1) RH Nut Plate
- (2) 3/4" D-Rings
- (1) LH Fog Light Bracket
- (1) RH Fog Light Bracket
- (1) Adaptive Cruise Control Plate

### WINCH BUMPER SPACER

---

- (2) Bumper Spacers
- (6) M12x1.75 x 65mm Bolts
- (6) M12 Lock Washers
- (6) M12 Flat Washers

### TOOLS REQUIRED

---

- 10mm, 15mm, 17mm, 19mm Sockets
- Plastic Panel Removal Tool
- Phillips Screwdriver
- 3mm, 4mm Allen Keys/Sockets

SKU # FB16213  
Edited: 06/08/2022



## STEP 1

Remove (6) 15mm bolts from the lower splash shield.

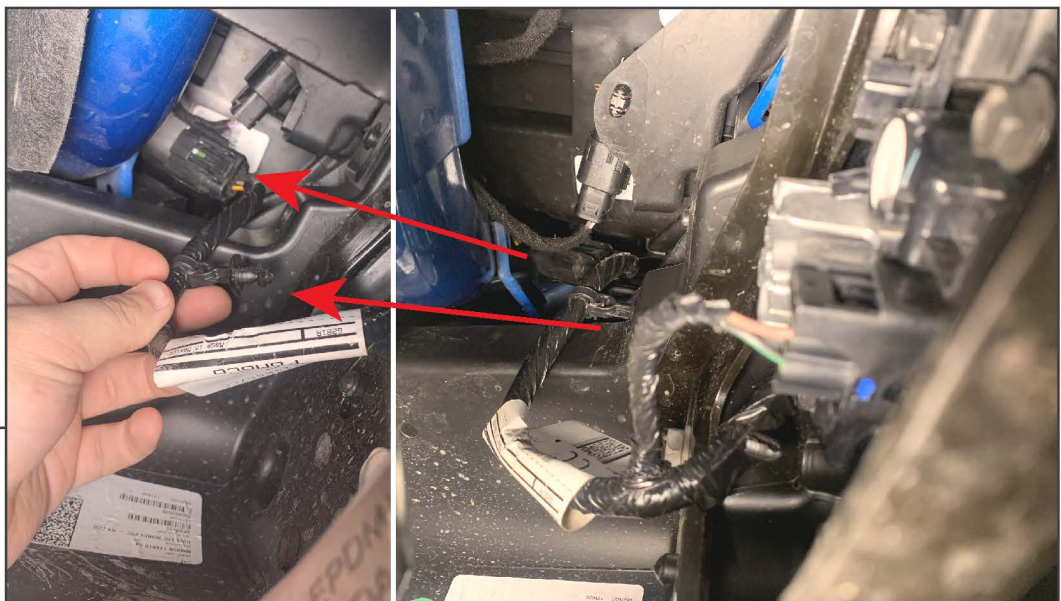

## STEP 2

From under the bumper, reach upwards and unplug the fog light harness main connector located under the LH (Driver Side) headlight. Pull the plastic harness retainer from the vehicle.



**STEP 3**

Remove the (2) plastic bumper covers using a plastic panel removal tool to reveal the bumper mounting hardware.



**STEP 4**

Remove (6) 15mm bolts from the front bumper, and remove the bumper assembly from the vehicle.

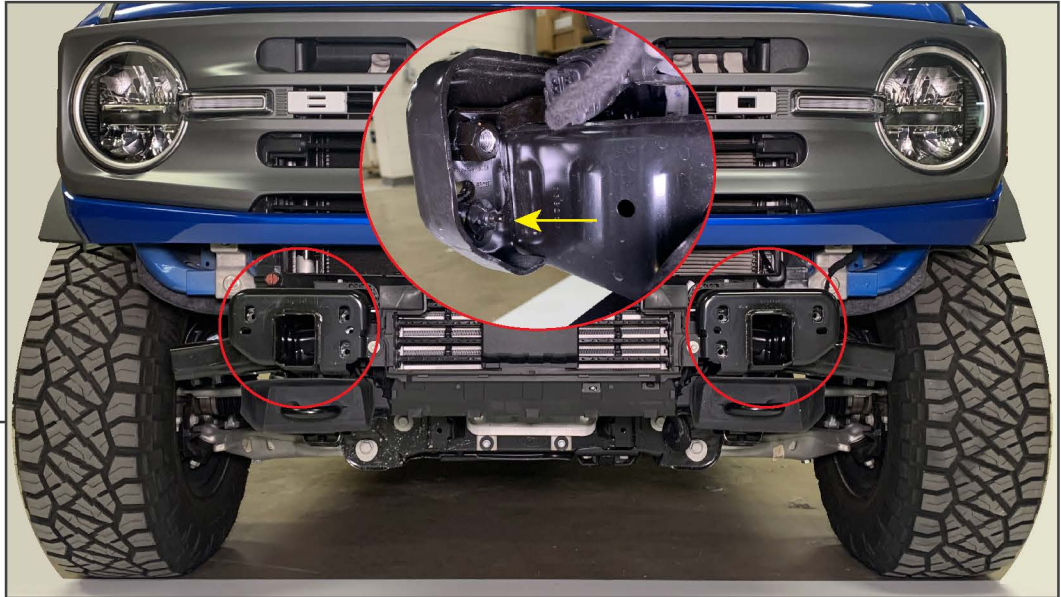
**STEP 5**

Unthread the (1) plastic wing nut from each of the bumper mounting nut plates, and remove each nut plate from the vehicle.

Note: If the vehicle has Adaptive Cruise Control, see step 13-18 for module removal/transfer.

**STEP 6**

Remove (4) 10mm bolts and (4) 15mm bolts to remove the bumper brace to release the fog light and proximity sensor harness from the bumper assembly.

See the following pages for proximity sensor removal steps.

**STEP 7**

Unplug the wiring harness from each fog light and proximity sensor. The proximity sensors can be used on the new bumper.

See the following pages for proximity sensor mounting options.

**STEP 8**

Place the new bumper on a soft surface. See the following steps regarding proximity sensor mounting.

Once proximity sensors are addressed, proceed to Step 9.

**SENSOR  
REMOVAL**

Optional: If equipped with bumper sensors, unplug the sensors by pressing the connector tab inwards while pulling up. Disconnect the wiring harness retaining clips from the bumper using a plastic panel removal tool and remove the harness.

**SENSOR  
REMOVAL**

Remove the sensors from the bumper by using a small flat head screwdriver or pick to gently pry back the mounting tabs.

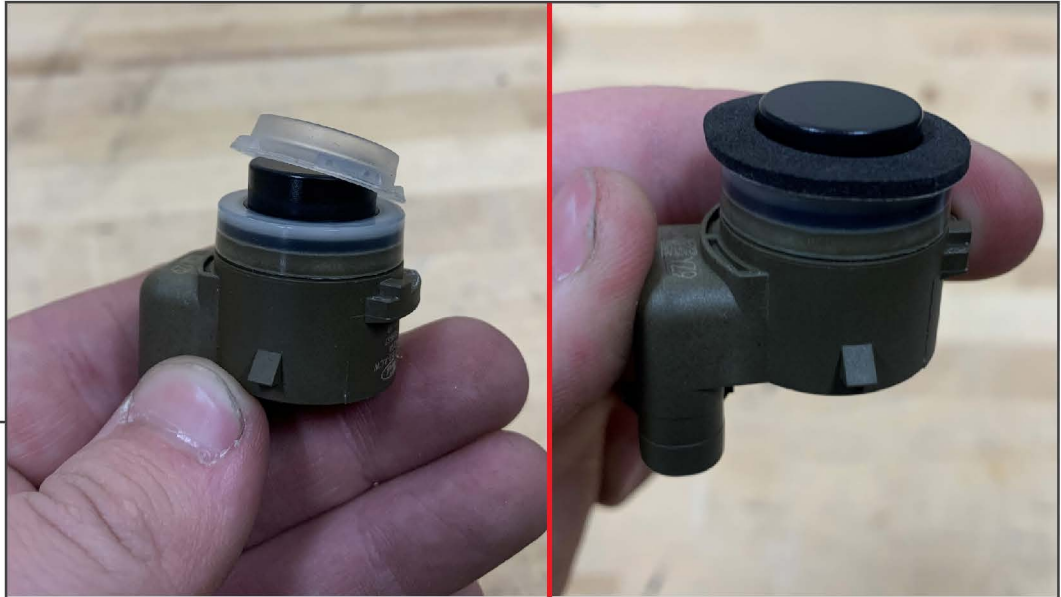
**SENSOR  
REMOVAL**

Remove the rubber gasket from around the sensor. Install the provided foam ring gasket around the sensor.

**INSTALLATION  
(OPTION 1)**

Place the sensor into the designated port, ensuring the mounting tabs are within the slots. Adhere (1) rubber grommet to the sensor using the attached adhesive. Place (1) foam pad onto the rubber grommet. Place the (1) plastic cap onto the assembly, ensuring the (2) tabs lock into place to secure the sensor tightly to the port.

---

**INSTALLATION  
(OPTION 2)**

Place the sensor into the designated port, ensuring the mounting tabs are within the slots. Using (2) Phillips screws, gently tighten the screws until moderate pressure is on the sides of the sensor to hold the sensor into place.

**Note:** Do NOT over-tighten the screws as the sensor can become damaged.

---

**OPTION 3  
(NO SENSORS)**

If vehicle is not equipped with sensors, press the plastic plug into the sensor port until the plug is flush with the port.

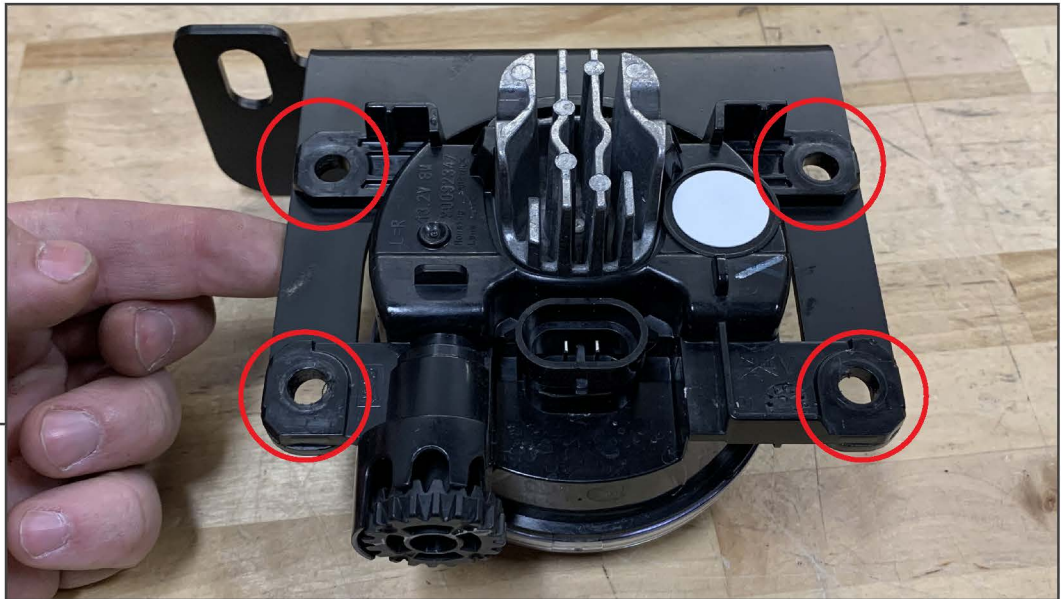

**STEP 9**

Secure each fog light to the included mounting bracket using (4) M6 x 20mm bolts, (8) M6 flat washers, (4) M6 lock washers, and (4) M6 nuts. Tighten until secure.

**STEP 10**

The fog light brackets and the over-riding bar share mounting hardware. Align the over-riding bar and the fog light bracket to the bumper, and take note to the common bolt holes. Secure the over-riding bar to the bumper using (1) M8 x 25mm Allen bolt, (2) M8 flat washers, and (1) M8 flange nut in the uncommon bolt hole on each side.

With the over-riding in place, secure the fog light bracket to the bumper on each side using (2) M8 x 25mm Allen bolts, (4) M8 flat washers, and (2) M8 flange nuts in the shared bolt holes.

**STEP 11**

Place the (2) bumper mounting nut plates behind the vehicle frame rails. With assistance, install the bumper to the vehicle frame rails using (6) M12 x 50mm bolts, (6) M12 flat washers, and (6) M12 lock washers. Do not fully tighten to allow for adjustment later.

**Note:** Some winches may interfere with the vehicle painted trim panel. For additional clearance, fit the (2) bumper spacers in-between the frame rail and the bumper, and secure into place using the (6) M12x1.75 x 65mm bolts, lock washers, and flat washers.

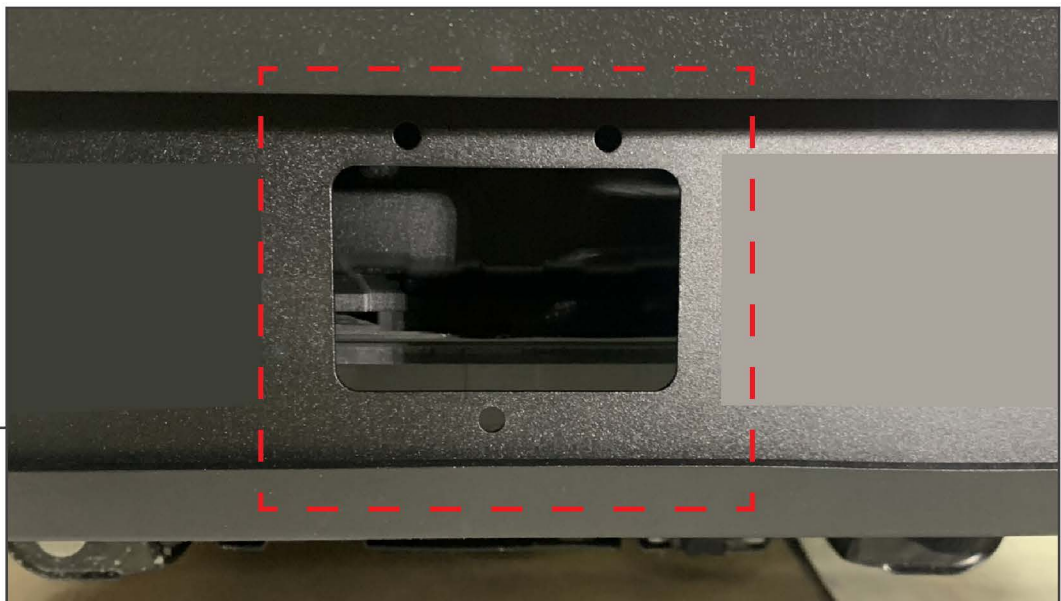
**STEP 12**

If the vehicle is equipped with Adaptive Cruise Control (ACC), transfer the module in the center of the vehicle to the bumper using (3) M6 x 25mm bolts, (6) M6 flat washers, and (3) M6 lock nuts. See steps 13-18.

If vehicle is not equipped with Adaptive Cruise Control (ACC), install the included block off plate using (3) M6 x 25mm bolts, (6) M6 flat washers, and (3) M6 lock nuts. **\*Note: The plate is directional.**

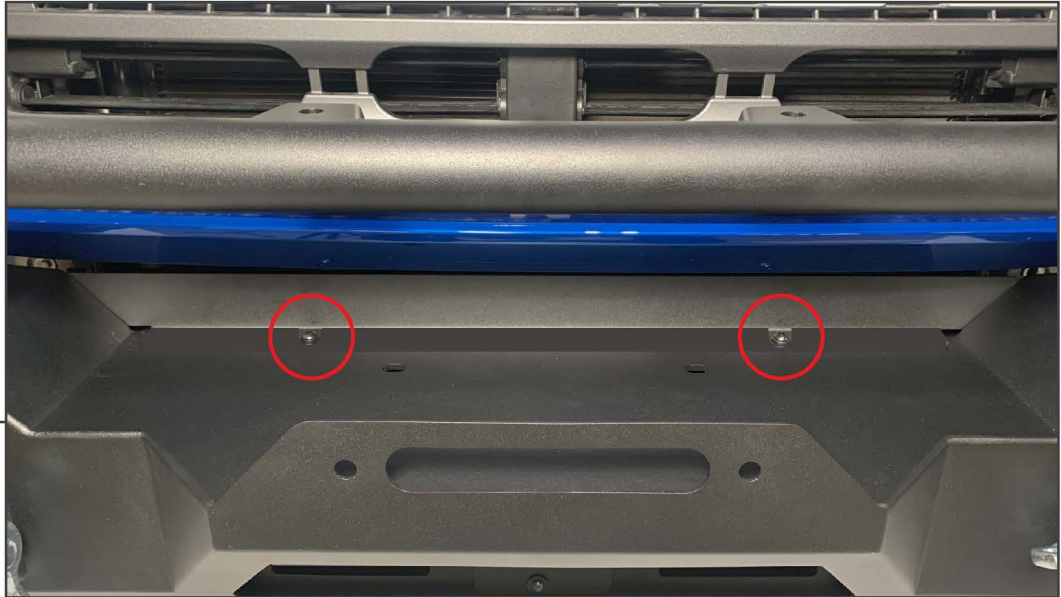
**STEP 19**

Install the rear block off plate to the bumper. Plate the panel under the bumper winch plate surface, and secure using (2) M8 x 30mm bolts, (2) M8 flat washers, and (2) M8 flange nuts.

**STEP 20**

Install the (2) 3/4" D-Rings to the front bumper mounting points.

Installation is now complete.

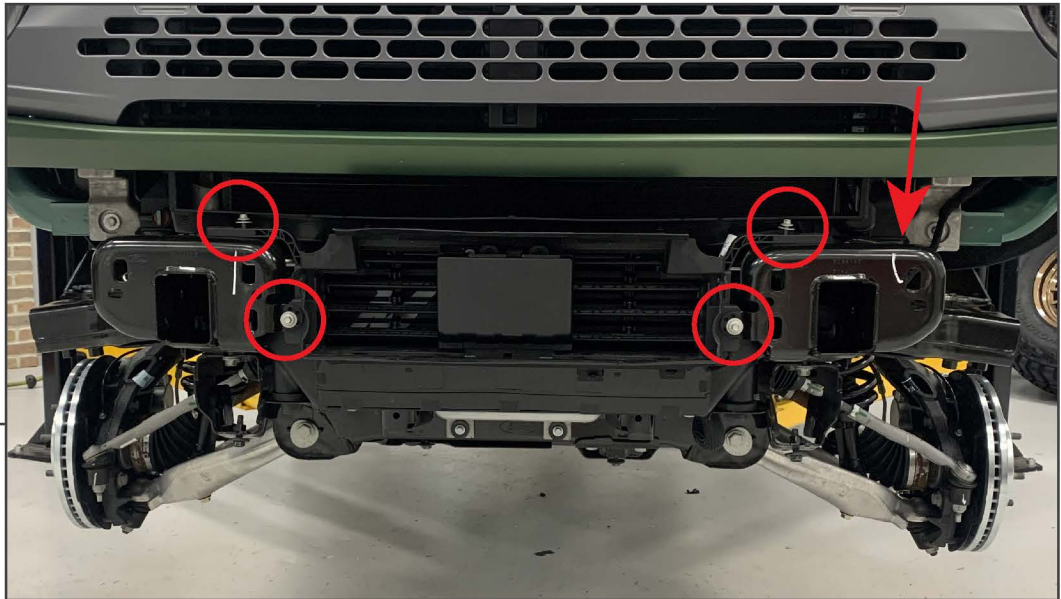
**STEP 13**

With the bumper removed, locate the front lower shutter assembly. Unplug the wiring harness connector along the LH side of the vehicle, and remove (4) 8mm bolts from the shutter assembly. Remove the shutter assembly from the vehicle and place on a workable surface.

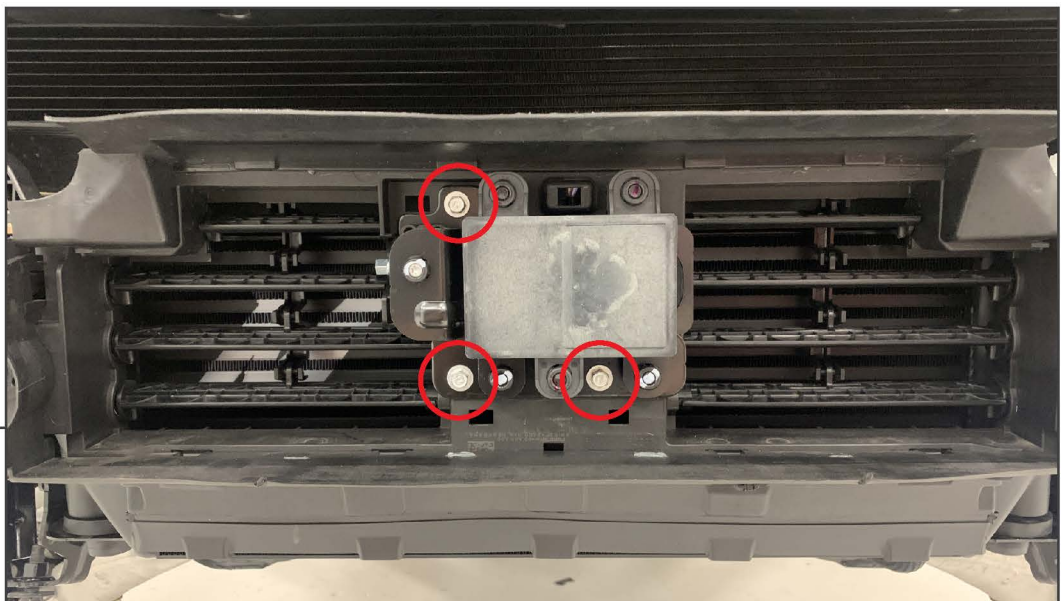
**STEP 14**

Remove (3) 8mm bolts from the Adaptive Cruise Control [ACC] module.



**STEP 15**

Unplug the ACC module from the shutter assembly wiring harness.



**STEP 16**

Using a pry tool, gently pry the ACC module away from the retaining bracket. The brackets are secured to the module using friction-fit ball studs.

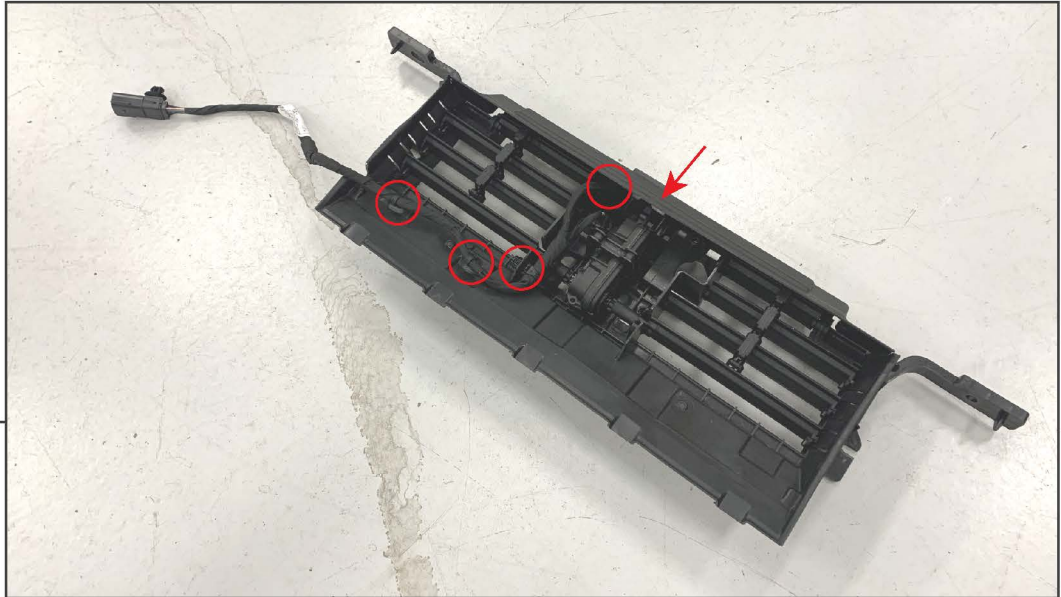
**STEP 17**

Unplug the shutter assembly motor by sliding the red lock, and pressing the tab. Then, use a pry tool to dislodge the wiring harness from the shutter assembly. With the harness removed, mount the shutter assembly to the vehicle using the original (4) 8mm bolts.

**STEP 18**

Mount the ACC module to the bumper using (3) M6 x 25mm bolts, (3) M6 flat washers, and (3) M6 flange nuts, tighten until secure. The module can be installed in front or behind the bumper.

With the bumper mounted to the vehicle, route the wiring harness to the ACC module, shutter assembly motor, and the vehicle chassis connector. Clip the lower (3) clips into the vehicle shutter assembly to retain the harness. \*\*Ensure the harness is routed away from any moving parts of the shutter assembly and is not stressed when mounted.