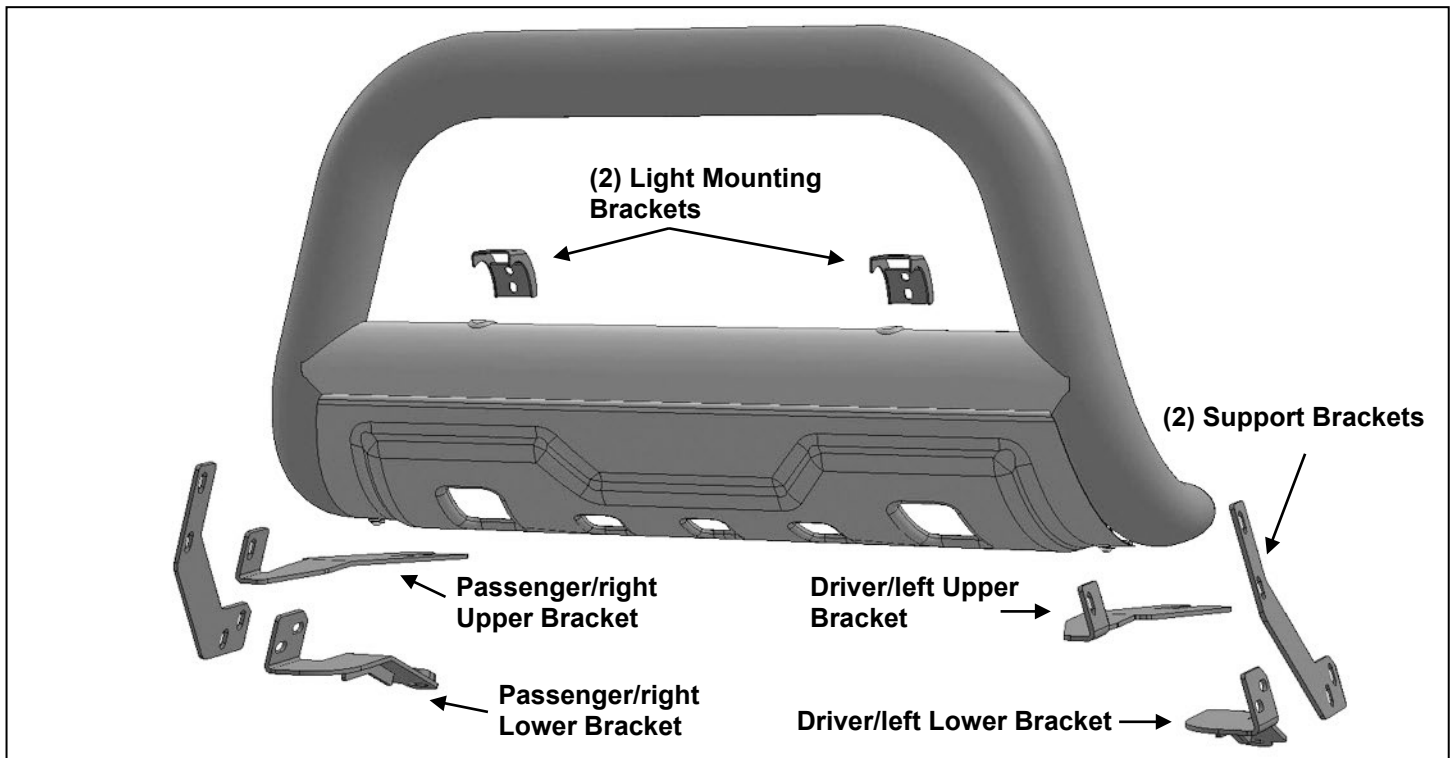

PARTS LIST:

1	3.5in Bull Bar	6	10-1.5mm x 30mm Hex Bolts
1	Driver/left Lower Bracket	18	10mm x 30mm OD x 2.5 mm Flat Washers
1	Passenger/Right Lower Bracket	2	10mm Lock Washers
2	Support Brackets	8	10-1.5mm Nylon Lock Nuts
1	Driver/left Upper Bracket	4	6-1.0mm x 20mm Button Head Screws
1	Passenger/Right Upper Bracket	4	6mm x 18mm OD x 1.6mm Flat Washers
2	Light Brackets	4	6mm Lock Washers
4	10-1.5mm x 40mm Hex Bolts	1	Wrench

**PROCEDURE:**

REMOVE CONTENTS FROM BOX AND VERIFY ALL PARTS ARE PRESENT. READ INSTRUCTIONS CAREFULLY. CUTTING MAY BE REQUIRED. INSTALLATION MAY INTERFERE WITH FRONT MOUNTED SENSORS.

1. Start installation from under the front of the vehicle. Remove the splash guard from below the bumper, **(Figure 1)**.
2. Determine if the vehicle is equipped with plastic bumper cover or steel option bumper.

Models with plastic bumper cover:

- a. Remove the plastic cover surrounding the driver/left tow hook, **(Figure 1)**. **NOTE:** Cover cannot be reinstalled.
- b. Loosen the (2) hex bolts attaching the tow hook to the bottom of the frame, **(Figure 2)**. **IMPORTANT;** Do not remove the hex bolts, only loosen.
- a. Select the driver/left Upper Mounting Bracket, **(Figure 3)**.
- b. Insert the Upper Bracket through the gap between the bottom of the frame and the top of the tow hook. Tighten hardware at this time.
- c. Repeat the previous Steps to install the passenger/right Upper Mounting Bracket.
- d. Reinstall the splash guard.

Models with optional steel bumper:

- a. Remove the driver/left side cover surrounding the tow hook from the bumper, **(Figure 4)**.
- b. Loosen the (2) hex bolts attaching the splash guard bracket to the bottom of the frame. **IMPORTANT;** Do not remove the hex bolts, only loosen.

- c. Select the driver/left Upper Mounting Bracket, **(Figure 3)**.
 - d. Insert the Support Bracket through the opening between the bottom of the tow hook and the bumper, **(Figure 5)**. Slide the end of the Bracket between the splash guard bracket and the bottom of the frame. Tighten bracket hardware at this time.
 - e. Reinstall the cover surrounding the tow hook.
 - f. Repeat the previous **Steps** to install the passenger/right Upper Mounting Bracket.
 - g. Reinstall the lower splash guard.
3. Select the driver/left Lower Mounting Bracket, **(Figure 6)**.
 4. Hold the Bracket up to the bottom of the splash guard. Line up the hole in the Bracket with the mounting bolt hole for the splash guard. Attach the Bracket to the Spacer and splash guard with (1) 10mm x 40mm Hex bolt, (1) 10mm Lock Washer and (1) 10mm Flat Washer, **(Figure 6)**. Leave hardware loose.
 5. Next, select (1) outer Support Bracket. Attach the Support Bracket to the outside of the Lower Mounting Bracket with the included (2) 10mm x 30mm Hex Bolts, (4) 10mm Flat Washers and (2) 10mm Nylon Lock Nuts, **(Figure 8)**. Leave hardware loose.
 6. Repeat **Steps 3—5** to attach the passenger/right Lower Mounting Bracket and Support Bracket.
 7. Carefully unwrap the Bull Bar.
 8. With assistance, hold the Bull Bar in position up to the Mounting Brackets. Slide the mounting tab on the driver/left side of the Bull Bar between the Upper Mounting Bracket and outer Support Bracket, **(Figure 9)**. Insert (1) 10mm x 40mm Hex Bolt, (2) 10mm Flat Washers and (1) 10mm Nylon Lock Nut through the lower hole in the Support Bracket, tab on Bull Bar and Upper Bracket. Insert (1) 10mm x 30mm Hex Bolt, (2) 10mm Flat Washers and (1) 10mm Nylon Lock Nut through the top hole in the Support Bracket and Bull Bar, **(Figure 9)**.
 9. Repeat **Step 8** to attach the passenger/right side of the Bull Bar.
 10. Check the Bull Bar alignment with the vehicle and for clearance between the Bull Bar and the bumper. Adjust as required then fully tighten all hardware at this time.
 11. Determine if accessory lights will be installed.
If lights will not be installed at this time:
 - a. Insert the included (4) 6mm x 20mm Button Head Bolts, (4) 6mm Lock Washers and (4) 6mm Flat Washers into the threaded inserts in the back of the crossbar to plug the holes, **(Figure 10)**. Tighten hardware. Installation is complete.**If aftermarket lights will be installed, (lights not included):**
 - a. Select (1) Light Mount, **(Figure 11)**. Use the hardware included with the light to attach the light to the top of the Light Mount. If light has a separate tilt feature, fully tighten base mounting hardware, **(See example Figure 12)**. If light adjusts with the base mounting hardware, skip to **Step 7b**.
 - b. Remove the rubber plug from the top of the crossbar. Attach the light and Light Mount to the back of the Bull Bar with the included (4) 6mm x 20mm Button Head Bolts, (4) 6mm Lock Washers and (4) 6mm Flat Washers, **(Figure 12)**. **NOTE:** If light adjusts with the base mounting hardware, hand-tighten the light hardware; do not fully tighten hardware at this time. You may have to install, adjust, remove light with Bracket and readjust a few times to get the light properly adjusted.
 - c. Once properly adjusted, tighten light to Bracket hardware then tighten Bracket to Bull Bar hardware.
 - d. Repeat the above **Steps 11a—11c** to install remaining light and Light Mount.
 12. Do periodic inspections to the installation to make sure that all hardware is secure and tight.

To protect your investment, wax this product after installing. Regular waxing is recommended to add a protective layer over the finish. Do not use any type of polish or wax that may contain abrasives that could damage the finish.

For stainless steel: Aluminum polish may be used to polish small scratches and scuffs on the finish. Mild soap may be used also to clean the Bull Bar.

For gloss black finishes: Mild soap may be used to clean the Bull Bar.

Driver/left Side Installation Pictured

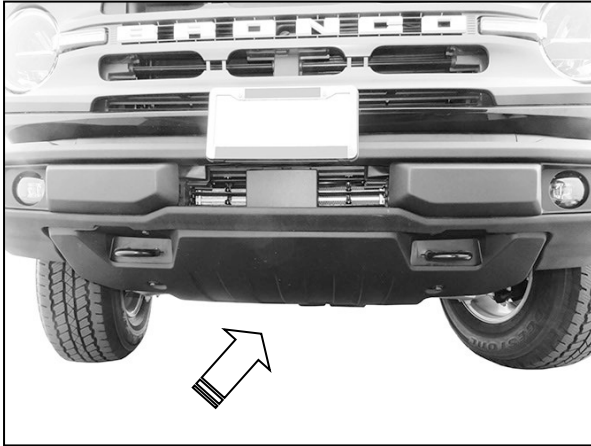

(Fig 1) Example of model with plastic bumper cover. Remove splash guard (arrow)

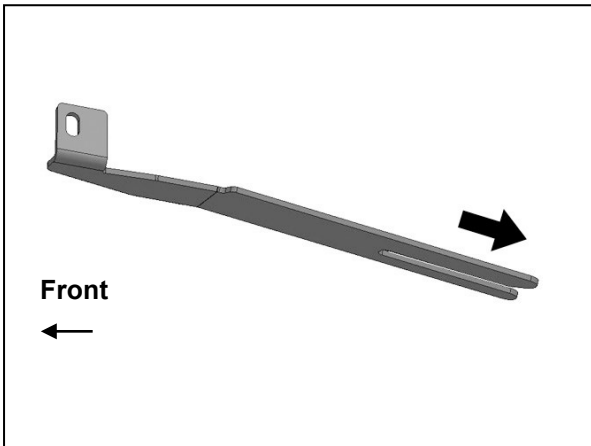

(Fig 3) Insert driver/left Upper Mounting Bracket between frame and tow hook. Models with plastic bumper cover, insert driver/left Support Bracket between frame and tow hook

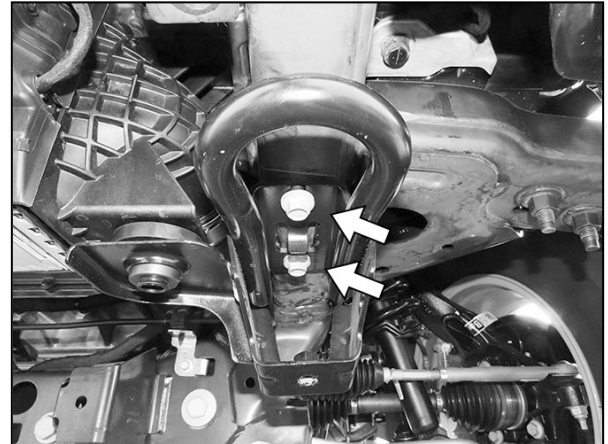

(Fig 2) Remove plastic cover surrounding tow hook. Loosen tow hook bolts (arrows)

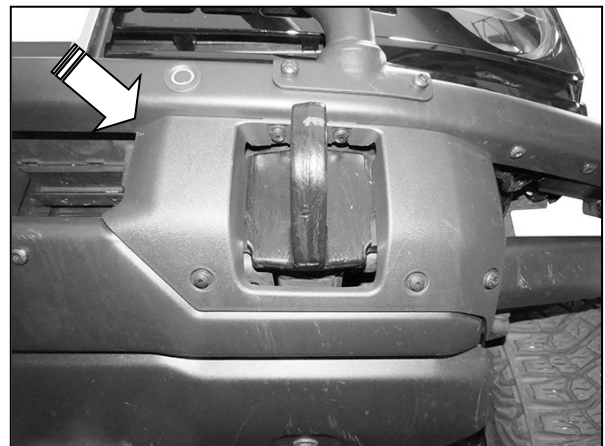

(Fig 4) Model with steel bumper, remove lower splash guard/skid plate and cover around tow hook (driver/left side pictured)

Driver/left Side Installation Pictured



(Fig 5) Models with steel bumper, insert Upper Bracket between tow hook and opening in bumper (arrow). Attach end of Bracket to bottom of frame, between frame and splash guard bracket. Reinstall splash guard/skid plate and cover

- 10mm x 40mm Hex Bolt
- 10mm Lock Washer
- 10mm Flat Washer

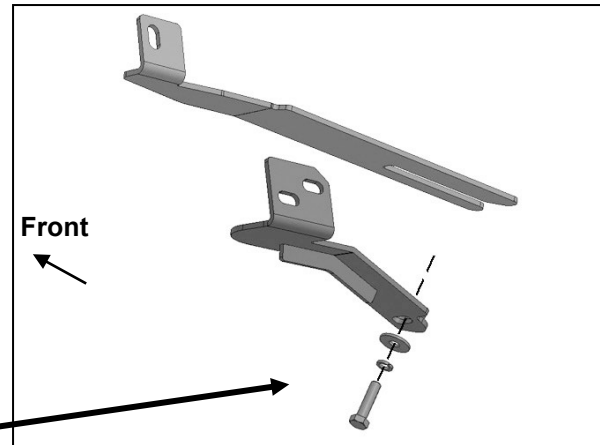

(Fig 6) Attach driver/left Mounting Bracket to the outside of the splash guard

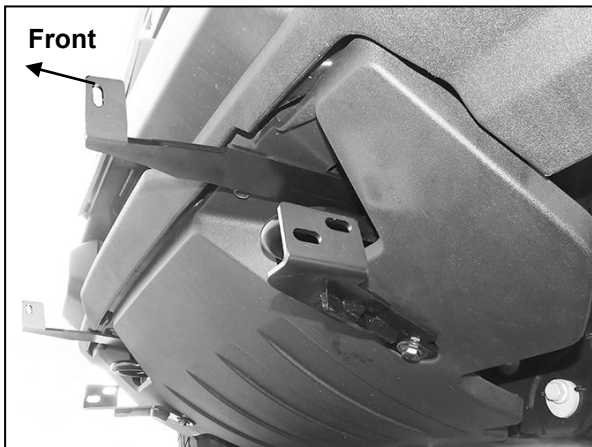

(Fig 7) Driver/left side Upper and Lower Mounting Brackets attached to model with plastic bumper

- (2) 10mm x 30mm Hex Bolts
- (4) 10mm Flat Washer
- (2) 10mm Nylon Lock Nuts

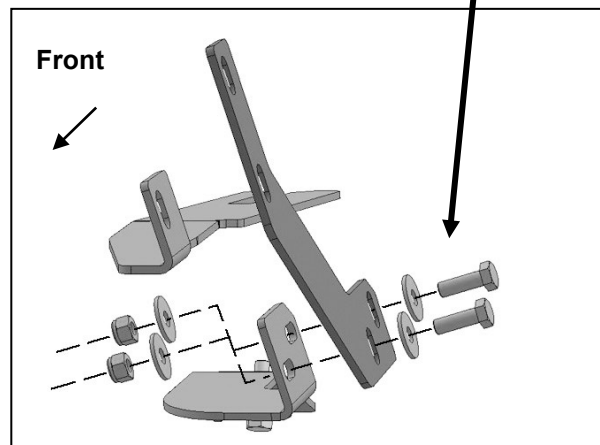

(Fig 8) Attach Support Bracket to outside of driver/left side Lower Mounting Bracket

Driver/left Side Installation Pictured

Top
10mm x 30mm Hex Bolt
(2) 10mm Flat Washers
10mm Nylon Lock Nut

Bottom
10mm x 40mm Hex Bolt
(2) 10mm Flat Washers
10mm Nylon Lock Nut

(2) 6mm x 20mm
Button Head Bolts
(2) 6mm Lock Washers
(2) 6mm Flat Washers

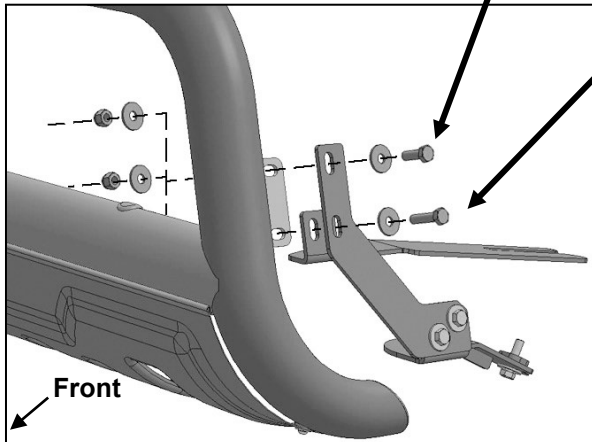

(Fig 9) Insert tab on driver/left end of Bull Bar between Outer Support Bracket and Upper Mounting Bracket

