

INSTALLATION INSTRUCTIONS

REDROCK 4X4 HD SPARE TIRE MOUNT FOR TIRES UP TO 35-INCHES

2021-22 FORD BRONCO

FB13744

PARTS LIST:

1	Spare Tire Carrier Mounting Bracket	4	8mm Lock Washers
1	Brake Light Relocation Bracket	4	8-1.25mm x 20mm Hex Bolts
2	Rubber Bumper Relocation Brackets	8	8mm Nylon Lock Nuts
2	Plastic Plugs	10	6mm x 18mm x 1.6mm Flat Washers
2	8mm Double Bolt Plates	4	6mm Lock Washers
4	8mm Single Bolt Plates	4	6mm Hex Nuts
8	8mm Plastic Retainers	4	6-1.0mm x 20mm Hex Bolts
12	8mm x 22mm x 2mm Flat Washers	2	6mm x 25mm Self Tapping Screws

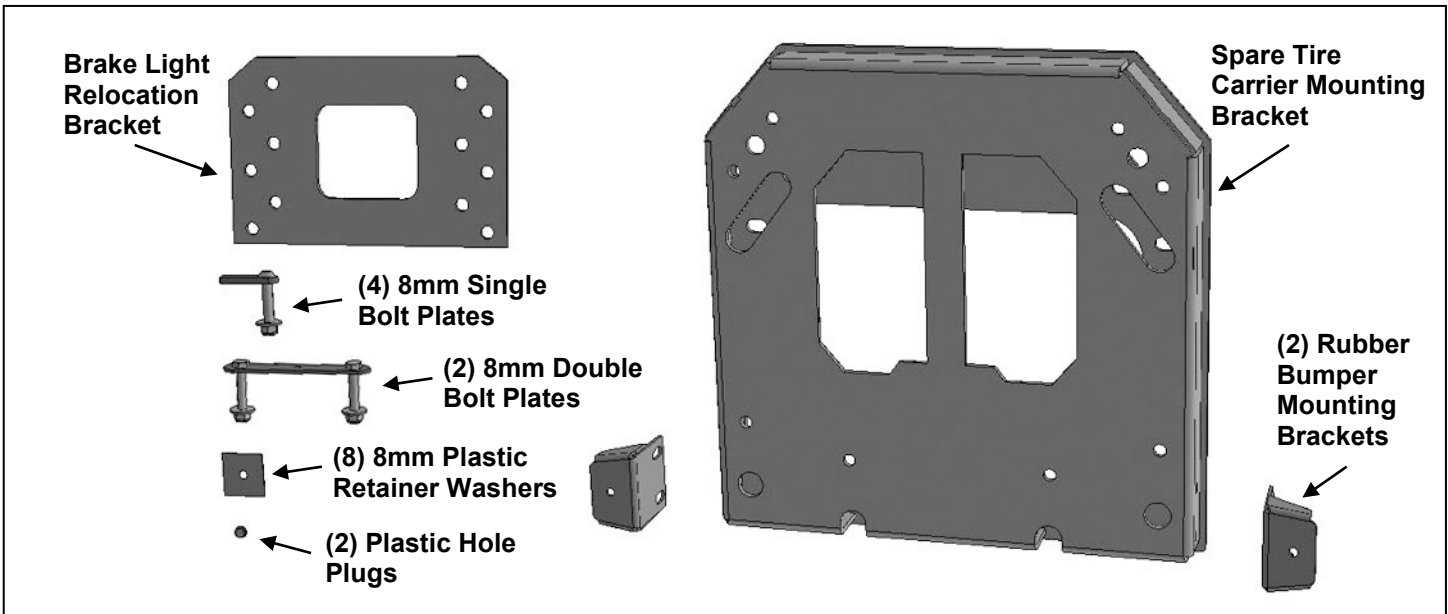

PROCEDURE:

REMOVE CONTENTS FROM BOX. VERIFY ALL PARTS ARE PRESENT. READ INSTRUCTIONS CAREFULLY BEFORE STARTING INSTALLATION. ASSISTANCE IS RECOMMENDED.

1. Open the rear door and remove the large plastic cover from the back of the door, **(Figure 1)**. **NOTE:** Use a non-marring automotive panel tool to carefully pry up the sides of the cover to remove.
2. Disconnect the wire harness leading to the CHMSL, (3rd brake light), and the camera if equipped, **(Figure 2)**. Pull the wire harness and grommet back through the outer door, **(Figure 3)**. Close the door.
3. With assistance, remove the spare tire and spare tire mount assembly with light and camera from the door, **(Figures 3 & 4)**. Remove both rubber bumpers from the door.
4. Remove the CHMSL light and bracket assembly from the top of the factory spare tire mount, **(Figures 5 & 6)**.
5. Unwrap the Offset Spare Tire Carrier. Select the (1) 8mm Single Bolt Plate and (1) 8mm Plastic Retainer. Insert the Bolt Plate through the upper hole on the back of the Tire Carrier, **(Figure 7)**. Thread the Plastic Retainer onto the Bolt Plate to help hold in position, **(Figure 9)**. Repeat this Step to install the remaining (3) Single Bolt Plates.
6. Select (1) 8mm Double Bolt Plate and (2) Plastic Retainers. Insert the Double Bolt Plate through the lower holes in the Tire Carrier, **(Figure 8)**. Thread the Plastic Retainers onto the Bolt Plate. Repeat this Step to install the remaining Double Bolt Plate, **(Figure 9)**.
7. Reuse the factory hardware to attach the Offset Spare Tire Carrier to the rear door, **(Figure 9)**. Fully tighten hardware at this time.
8. Select (1) Rubber Bumper Relocation Bracket. Attach the Bracket to the threaded holes in the passenger/right side of the Spare Tire Carrier with the included (2) 8mm Hex Bolts, (2) 8mm Lock Washers and (2) 8mm Flat Washers, **(Figure 10)**. Leave hardware loose at this time. Repeat this **Step** to attach the driver/left Bumper Relocation Bracket. Push the factory rubber bumpers into the center

holes in the Relocation Brackets, **(Figure 11)**. Use the included (2) Plastic Plugs to plug the old mounting holes in the rear door.

9. Use the included (8) 8mm Flat Washers and (8) 8mm Nylon Lock Nuts to attach the factory spare tire mount to the Spare Tire Carrier, **(Figure 12)**. Fully tighten hardware at this time.
10. Select the CHMSL Relocation Bracket. Reuse the (4) factory screws to attach the CHMSL light assembly to the back of the Light Relocation Bracket, **(Figure 13)**. Insert the included (2) Self Tapping Screws through the Relocation Bracket and into the light assembly and tighten all hardware, **(Figures 13 & 14)**.
11. Attach the Bracket to the back of the factory spare tire carrier with the included (4) 6mm x 20mm Hex Bolts, (8) 6mm Flat Washers, (4) 6mm Lock Washers and (4) 6mm Hex Nuts, **(Figure 14)**.
12. Reinstall the harness and rubber grommet. Plug the CHMSL harness and camera back into the main harness and reinstall the plastic cover.
13. With assistance, attach the spare tire to the tire mount studs. Check the fit between the Rubber Bumpers and the tire. Adjust the Bumpers to provide a little preload against the tire. Tighten all hardware at this time.
14. Do periodic inspections to the installation to make sure that all hardware is secure and tight.

To protect your investment, do not use any type of polish or wax that may contain abrasives that could damage the finish. Mild soap may be used to clean Tire Mount.

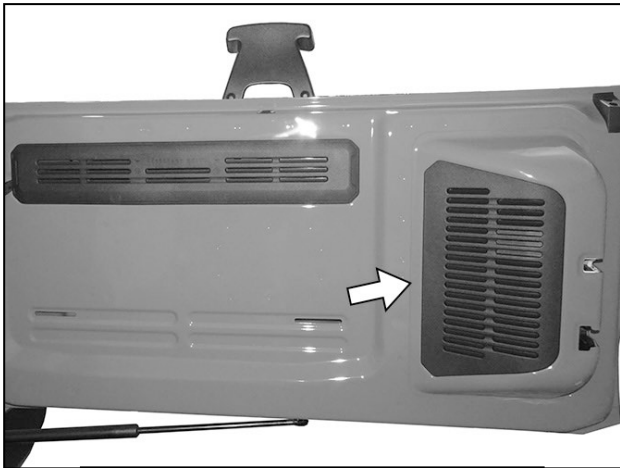

(Fig 1) Remove plastic cover from inside of rear door (arrow)



(Fig 2) Disconnect wire harnesses leading to the camera and CHMSL (3rd brake light). Release rubber grommet and pull harness through hole in rear door

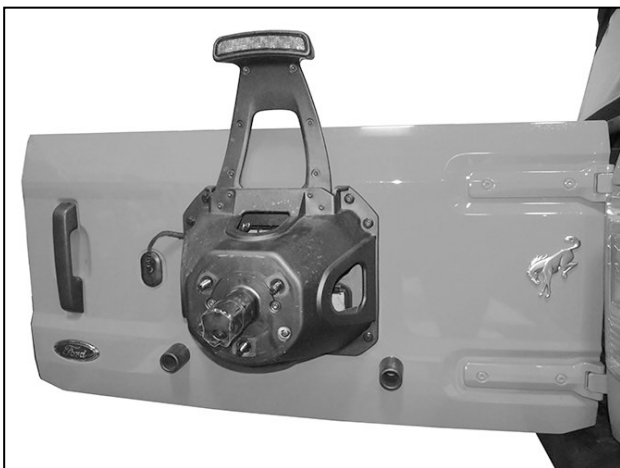

(Fig 3) Remove tire mount from rear door

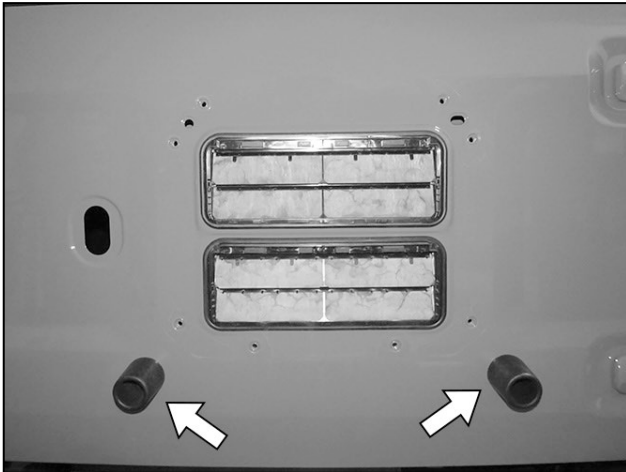

(Fig 4) Remove both rubber bumpers from rear door (arrows). Push the included (2) Plastic Plugs into the mounting holes

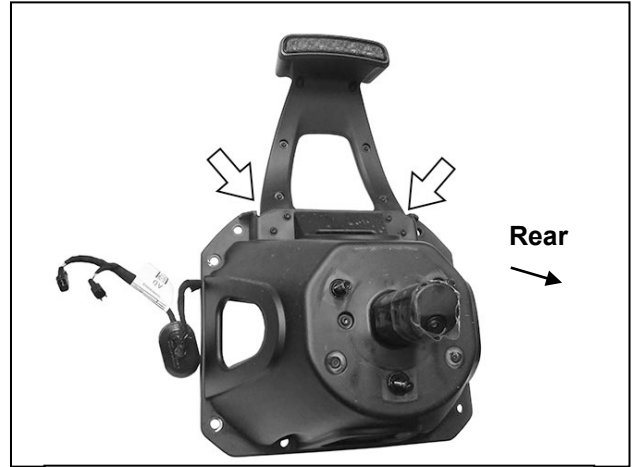

(Fig 5) Remove the brake light assembly from the top of the spare tire mount



(Fig 6) Remove the brake light assembly from the top of the spare tire mount

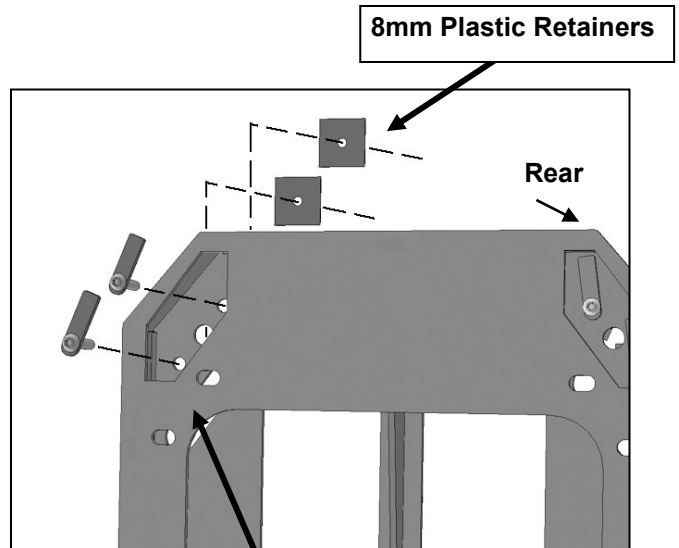

(Fig 7) Insert (4) 8mm Single Bolt Plates through upper mounting holes in the back of the Tire Carrier. Thread the Plastic Retainers onto the Bolt Plates to hold the Bolt Plates in position

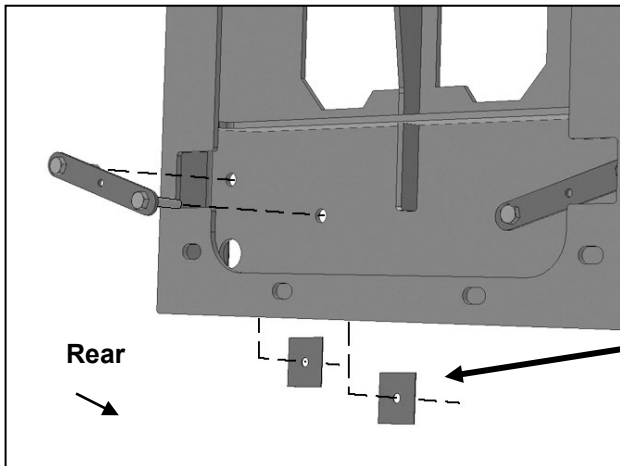

8mm Plastic Retainers

(Fig 8) Insert (2) 8mm Double Bolt Plates through lower mounting holes in the back of the Tire Carrier. Thread the Plastic Retainers onto the Bolt Plates to hold the Bolt Plates in position

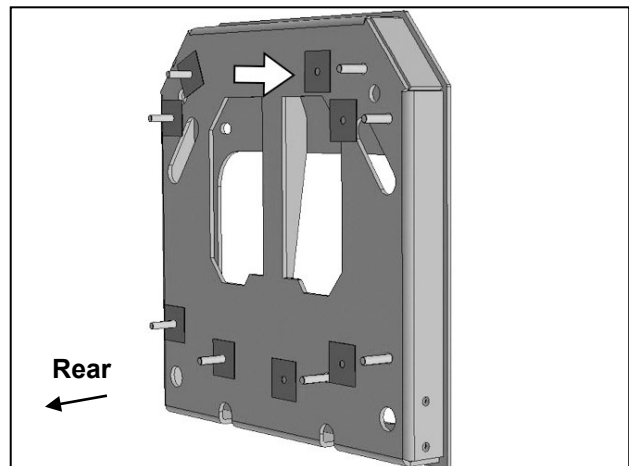

(Fig 9) Thread the Plastic Retainers onto the Bolt Plates to hold the Bolt Plates in position. Reuse the factory hardware to attach the Tire Carrier to the rear door

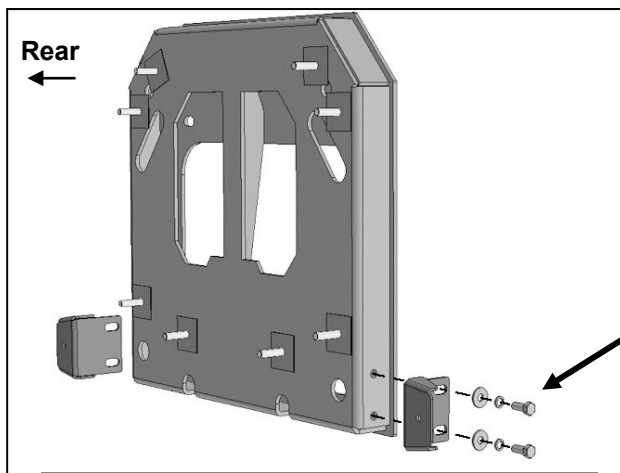

(2) 8mm x 20mm Hex Bolts
(2) 8mm Lock Washers
(2) 8mm Flat Washers

(Fig 10) Attach the (2) Bumper Relocation Brackets to sides of Tire Carrier

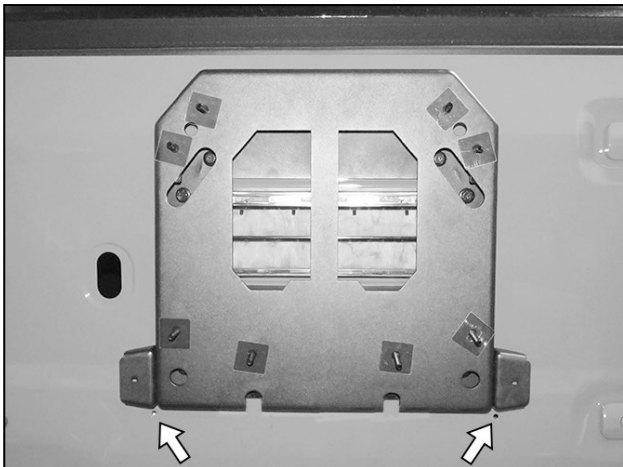

(Fig 11) Push the factory rubber bumpers into the Relocation Brackets. Use the included (2) Plastic Plugs to plug the mounting holes in the rear door (arrows)

- (8) 8mm Flat Washers
- (8) 8mm Nylon Lock Nuts

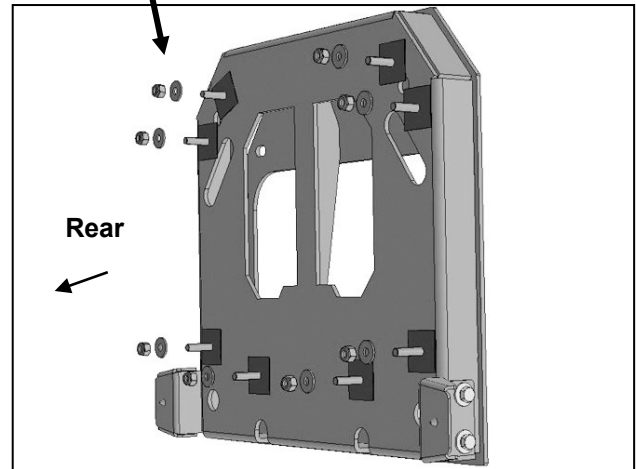

(Fig 12) Attach the factory spare tire mount to the Tire Carrier

- (2) Self Tapping Screws

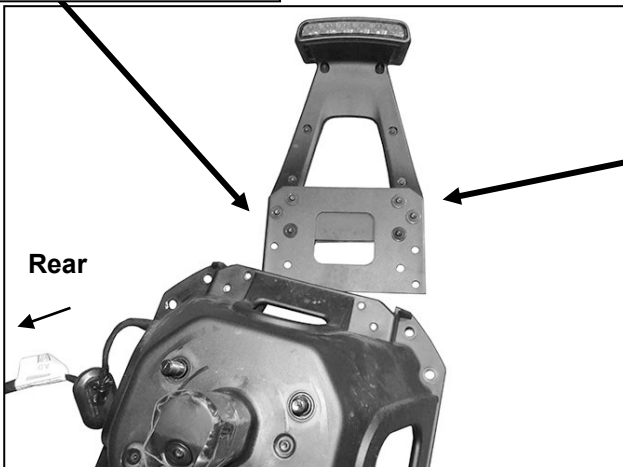

(Fig 13) Reuse the (4) factory screws to attach the brake light assembly to the back of the Relocation Bracket. Use the included (2) Self Tapping Screws to attach the bottom of the light assembly to the lower mounting holes in the Relocation Bracket (arrow)

- Reuse (4) factory screws

- (2) Self Tapping Screws
- (2) 6mm Flat Washers

- (4) 6mm x 20mm Hex Bolts
- (8) 6mm Flat Washers
- (4) 6mm Lock Washers
- (4) 6mm Hex Nuts

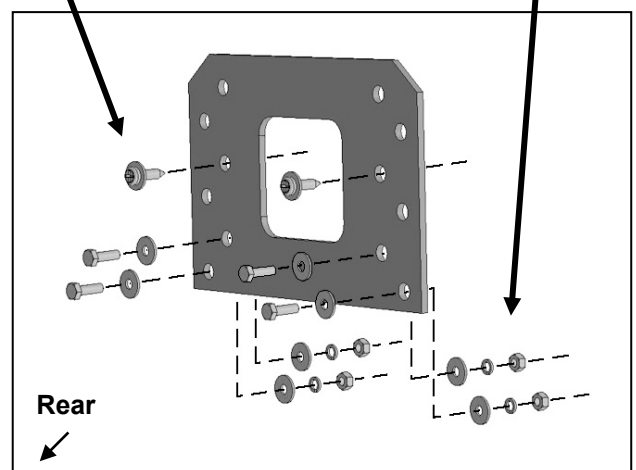

(Fig 14) Attach the Light assembly and Relocation Bracket to the back of the factory spare tire mount