



INSTALLATION INSTRUCTIONS

**CR-1 ROOF RACK
2021 FORD BRONCO 4-DOOR
FB13740**

**CR-1 ROOF RACK
2021 FORD BRONCO 4-DOOR**

PARTS LIST:

1	Front Crossbar Tube	(A)	1	Driver/left Rear Foam Body Seal	(Y)
1	Front Wind Fairing LED Surround	(B)	1	Passenger/right Rear Foam Body Seal	(Z)
2	Wind Fairing Mounting Brackets	(C)	16	Hole Plugs	
2	Wind Fairing Bracket Shims	(D)	4	10-1.50mm x 30mm Hex Bolts	
1	Driver/left LED "L" Bracket	(E)	4	10mm x 30mm x 2.5mm Flat washers	
1	Passenger/right LED "L" Bracket	(F)	4	10mm Lock Washer	
1	Driver/left Side Rail	(G)	2	8-1.25 x 25mm Combo Hex Bolts	
1	Passenger/right Side Rail	(H)	6	8-1.25 x 35mm Torx Button Head Bolts	
1	Driver/left Rear Corner Tube Assembly	(I)	18	8-1.25mm x 50mm Button Head Bolts	
1	Passenger/right Rear Corner Tube Assembly	(J)	10	8-1.25mm x 30mm Button Head Bolts	
1	Driver/left Ladder Support Tube	(K)	2	8-1.25 x 16mm Hex Bolts	
1	Passenger/right Ladder Support Tube	(L)	24	8mm x 24mm x 2mm Large Flat Washers	
1	Driver/left Ladder Step	(M)	6	8mm x 20mm x 2mm STD Flat Washers	
1	Passenger/right Ladder Step	(N)	36	8mm x 16mm x 1.6mm Small Flat Washers	
1	Rear Crossbar Tube	(O)	8	8mm Lock Washers	
4	Crossbars	(P)	9	8mm Flange Hex Nuts	
3	Offset Accessory Mounting Brackets	(Q)	2	8mm Hex Nuts	
1	Driver/left Rear Body Mounting Bracket	(R)	28	8mm Nylon Lock Nuts	
1	Passenger/right Rear Body Mounting Bracket	(S)	2	8mm Plastic Nut Caps	
1	Driver/Left Hardtop Front Top Spacers	(T)	4	6-1.0mm Flange Nuts	
1	Passenger/Right Hardtop Front Top Spacers	(U)	1	T-40 Torx Wrench	
2	Hardtop Upper Top Spacers	(V)	1	5mm Wrench	
1	Driver/left Hardtop Side Foam Body Seal	(W)	2	50mm x 750mm Hook Loop Strips	
1	Passenger/right Hardtop Side Foam Body Seal	(X)			

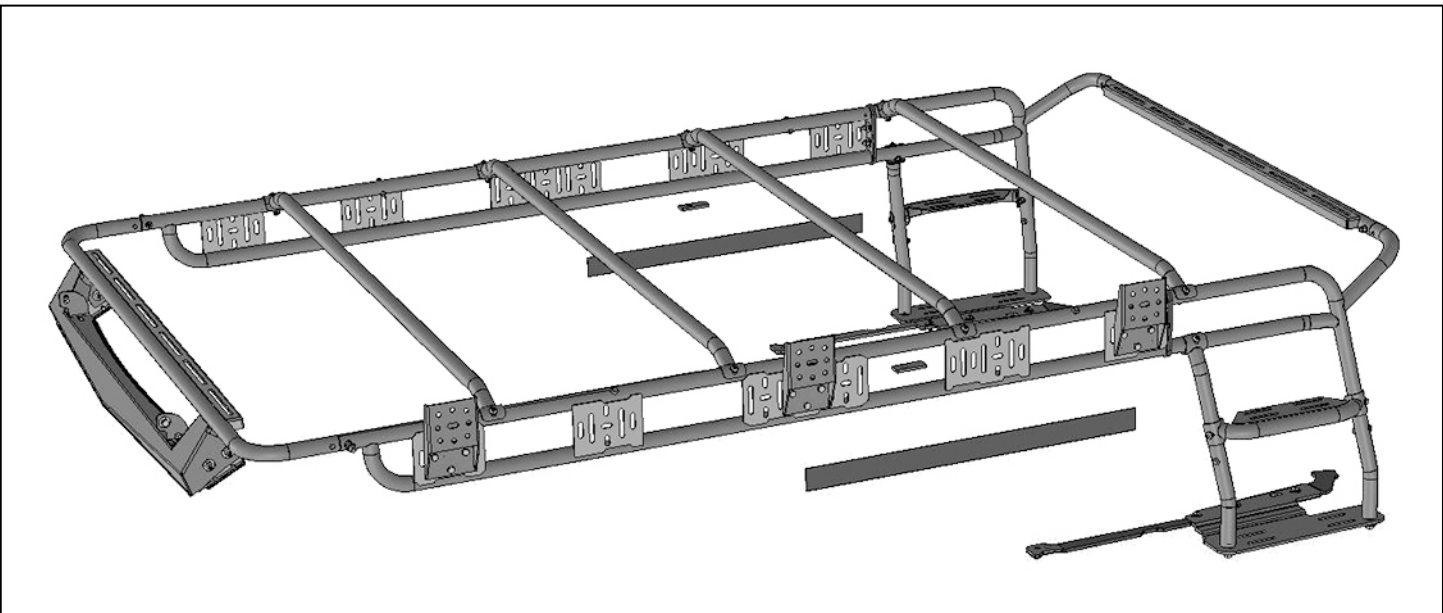

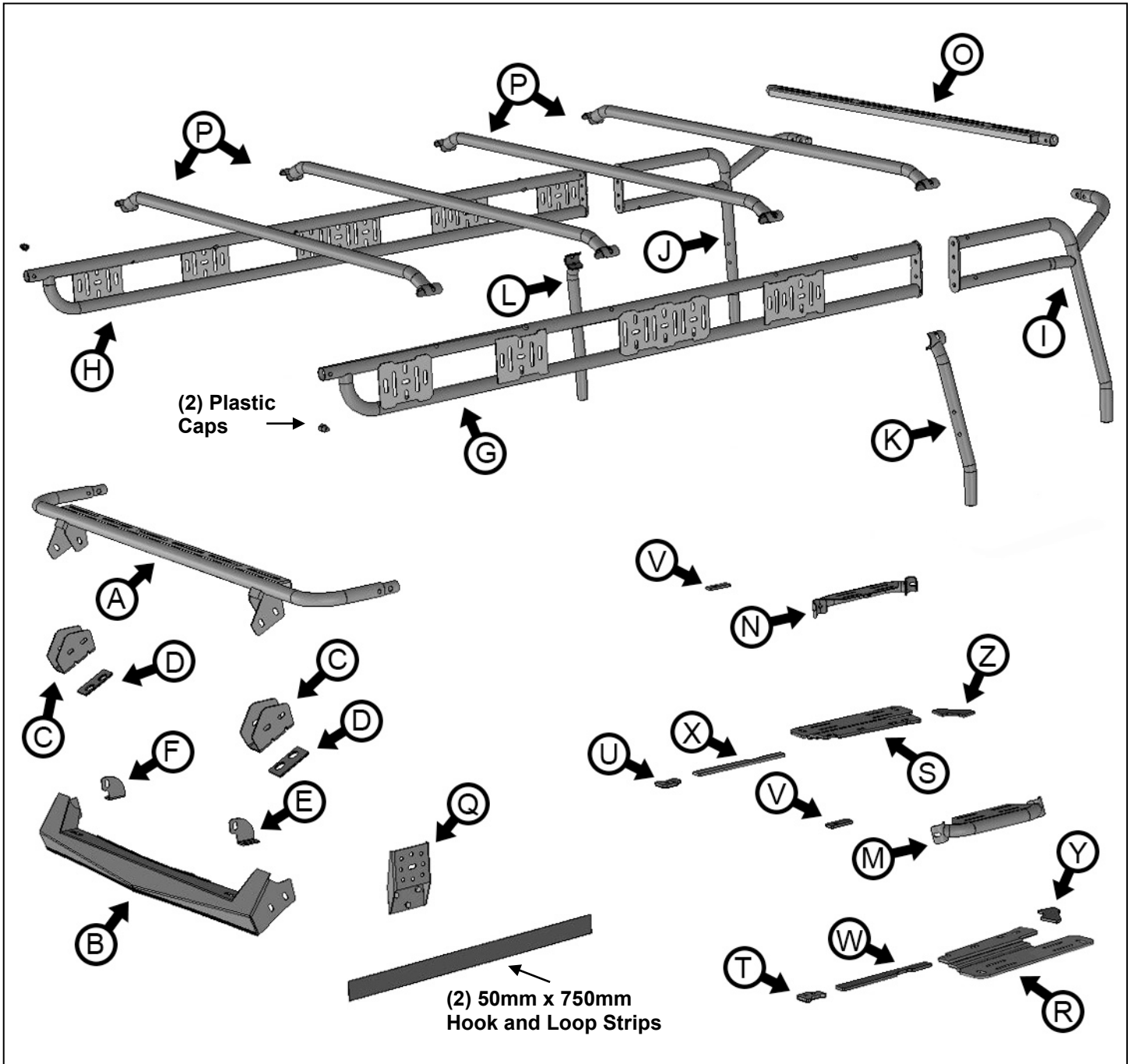

PROCEDURE:

REMOVE CONTENTS FROM BOX. VERIFY ALL PARTS ARE PRESENT. READ INSTRUCTIONS CAREFULLY. ASSISTANCE IS REQUIRED.

1. Hardtop models only, temporarily remove Freedom Top.
2. Determine if the vehicle is equipped with a factory accessory roof rack.

Hard Top models with roof rack

- a. Remove cover from top of roof rack mount, **(Figure 1)**.
- b. Remove tube nuts attaching end of roof rack, **(Figure 2)**. Repeat to remove remaining roof rack hardware and with assistance, remove entire roof rack rails.

Hard Top or Soft Top models without roof rack.

- a. Remove the plastic cover over the accessory mounting location, **(Figure 3)**.

- b. Remove the inner bracket, **(Figure 4)**. Repeat **Steps** to remove the passenger/right cover and bracket.
3. Select (1) Wind Fairing Bracket Shim, **(Figure 5)**, and (1) Wind Fairing Bracket, **(Figure 6)**. Slide the Shim and the Bracket over the driver/left side mounting studs. Reuse the factory 6mm Flange Nuts or the (2) included 6mm Flange Nuts to attach the Shim and Bracket to the accessory mount studs, **(Figure 7)**. Do not fully tighten hardware at this time. Repeat this Step to attach the passenger/right side Shim and Mounting Bracket.
4. Select the Front Crossbar. Attach the inner mounting plate on the Crossbar to the driver/left Bracket with the included (1) 8mm x 30mm Button Head Bolt, (2) 8mm x 24mm Large Flat Washers and (1) 8mm Nylon Lock Nut, **(Figure 8)**. Snug but do not fully tighten hardware at this time. Repeat this Step to attach the passenger/right side of the Crossbar to the Bracket, **(Figure 9)**.
5. Attach the Wind Fairing to the outside of the Brackets with the included (4) 8mm x 30mm Button Head Bolts, (8) 8mm x 24mm Large Flat Washers and (4) 8mm Nylon Lock Nuts, **(Figure 11)**. **NOTE:** Wind Fairing installation is optional.
 - a. **IMPORTANT:** If installing LED bar style light, (light not included, installation is optional), attach the driver/left and passenger/right LED “L” Brackets to the slots in the Wind Fairing first with the included (2) 8mm Combo Bolts, (2) 8mm x 24mm Large Flat Washers and (2) 8mm Hex Nuts, **(Figure 10)**. Then attach light to the “L” Brackets before installing Wind Fairing.
 - b. **NOTE: If Wind Fairing will not be installed,** attach the outer tabs on the Crossbar to the Brackets with the included (4) 8mm x 30mm Button Head Bolts, (8) 8mm x 24mm Large Flat Washers and (4) 8mm Nylon Lock Nuts, **(Figure 12)**. Do not fully tighten hardware at this time.
6. Determine if vehicle is equipped with hard top or soft top.

Hard Top Models

- a. Remove hardware attaching top to inner roll bar and the sides of the hard top to the body, (refer to owner’s manual). With assistance, remove hard top assembly. **NOTE:** Remove hard top or lift top up high enough and support hard top to install Seals, Spacers and Mounting Brackets.
- b. Select the lower driver/left front Top Spacer, **(Figure 13)**. Place Spacer over threaded hole in body and hole for alignment pin, **(Figure 14)**.
- c. Select the driver/left Mounting Bracket. Hold the Bracket in place over the threaded holes for the top hardware. Next, select the adhesive backed driver/left Top Side Seal, **(Figure 13)**. Remove the backing and attach the Top Seal to the body between the front Spacer and the Mounting Bracket, **(Figure 15)**. Do not attach Bracket at this time.
- d. Attach the adhesive backed driver/left Rear Top Seal to the top of the body, between the Mounting Bracket and the rear door opening, **(Figures 16 & 17)**.
- e. Repeat the previous Steps to attach the passenger/right front Spacer, Side and Rear Top Seal.
- f. Place the top assembly back in position on the vehicle but do not attach.
- g. With assistance, lift the driver/left side of the top up and insert the driver/left Mounting Bracket between the top and the body. Use the included (3) 8mm x 35mm Button Head Torx Bolts, (3) 8mm Lock Washers and (3) 8mm x 20mm STD Flat Washers to attach the top and Bracket, **(Figure 18)**. Reuse the factory bolt to attach the top to the Front Spacer and body. Leave hardware loose. Repeat to attach the passenger/right Bracket to the body and top.
- h. Next, insert (1) Top Spacer between the top bracket on the top and the inner roll bar, **(Figure 19)**. Reuse the factory bolt to attach the bracket and Spacer to the roll bar, **(Figure 20)**. Repeat this Step to insert (1) Spacer on the passenger/right side of the top.
- i. Align the top to the vehicle. Tighten the (2) top mounting bolts first, then tighten the bottom mounting bolts.
- j. Reinstall the freedom tops.

Soft Top models

- a. Temporarily remove the side and rear window panels, (refer to owner’s manual).
- b. Release the latches attaching the rear base on the top frame to the top of the body.
- c. With assistance, lift up the rear top frame. Attach the driver/left Mounting Bracket to the threaded holes in the top of the body with the included (3) 8mm x 35mm Button Head Torx Bolts, (3) 8mm Lock Washers and (3) 8mm x 20mm STD Flat Washers, **(Figures 21 & 22)**. Fully tighten hardware.

**CR-1 ROOF RACK
2021 FORD BRONCO 4-DOOR**

- d. Attach the adhesive backed driver/left Rear Top Seal to the top of the body, between the Mounting Bracket and the rear door opening, **(Figures 22 & 23)**.
 - e. Repeat previous Steps to attach the passenger/right Bracket and rear Seal.
 - f. Latch top frame to body.
 - g. Reinstall the rear and side windows. Fasten windows to clips.
 - h. Attach the included wider double-sided hook and loop strip to the top of the side windows, **(Figure 24)**. **NOTE:** The wider strip will help pull the side window up tighter in the opening.
 - i. Pull up slightly on side windows to remove sag and fasten to hook and loop strips and clips.
7. Select the driver/left Rear Corner Tube Assembly and driver/left Support Leg. Attach the Support Leg to the Corner Assembly with (1) 8mm x 50mm Button Head Bolt, (2) 8mm x 16mm Small Flat Washers and (1) 8mm Nylon Lock Nut, **(Figure 25)**. Next, attach the driver/left Corner Step to the two tubes with the included (2) 8mm x 50mm Button Head Bolts, (4) 8mm x 16mm Small Flat Washers and (2) 8mm Nylon Lock Nuts, **(Figure 26)**. **NOTE:** There are (2) sets of mounting holes to choose from for the Step, use the included (4) Plugs to seal off unused mounting holes. Repeat this **Step** to assemble the passenger/right Corner Assembly and Step.
 8. Attach the Rear Crossbar Tube to the driver/left and passenger/right Rear Corner Assemblies with (2) 8mm x 50mm Button Head Bolts, (4) 8mm x 16mm Small Flat Washers and (2) 8mm Nylon Lock Nuts, **(Figure 27)**. Attach (1) load Crossbar to the mounting holes in the top of the Corner Assemblies with (2) 8mm x 50mm Button Head Bolts, (4) 8mm x 16mm Small Flat Washers and (2) 8mm Nylon Lock Nuts, **(Figure 27)**.
 9. With assistance, carefully lift the rear Corner Assembly up and onto the rear Brackets. Do not slide the ends of the tubes on the Brackets to prevent damaging the finish. Attach the Rear Corner Assembly to the driver/left rear Bracket with the included (2) 10mm x 30mm Hex Bolts, (2) 10mm Lock Washers and (2) 10mm Flat Washers, **(Figure 28)**. Leave hardware loose at this time. Repeat this Step to attach the passenger/right side of the assembly.
 10. Select the driver/left Side Rail. Attach the front of the Side Rail to the Front Loop with the included (1) 8mm x 50mm Button Head Bolt, (2) 8mm x 16mm Small Flat Washers and (1) 8mm Nylon Lock Nut, **(Figure 29)**. **NOTE:** To clear the freedom top or soft top, insert Bolt from inside to outside. After Bolt has been fully tightened, cover Lock Nut on end of Bolt with included Plastic Cap. Attach the rear of the Side Rail to the front of the Rear Corner Assembly with (2) 8mm x 30mm Button Head Bolts, (4) 8mm x 24mm Large Flat Washers and (2) 8mm Nylon Lock Nuts, **(Figure 30)**. Repeat this **Step** to attach the passenger/right Side Rail to the Front Loop and Rear Corner Assembly.
 11. Select the (3) remaining Crossbars. Locate the mounting locations on the Side Rails for the crossbars. **NOTE:** Rack features multiple mounting locations, select the combination as desired. Attach each Crossbar to the top of the Side Rails with (2) 8mm x 50mm Button Head Bolts, (4) 8mm x 16mm Small Flat Washers and (2) 8mm Nylon Lock Nuts, **(Figure 31)**. Use the included Plugs to seal off unused mounting holes.
 12. Check the Roof Rack for alignment, adjust as necessary and fully tighten all hardware.
 13. Attach each Offset Accessory Mount to the Top Rail as desired with the included (3) 8mm Flange Nuts (2) 8mm x 50mm Button Head Bolts, (4) 8mm x 16mm Small Flat Washers and (2) 8mm Nylon Lock Nuts, **(Figure 32)**.
 14. Do periodic inspections to the installation to make sure that all hardware is secure and tight.

To protect your investment, Do not use any type of polish or wax that may contain abrasives that could damage the finish. Mild soap may be used to clean the Roof Rack.

**CR-1 ROOF RACK
2021 FORD BRONCO 4-DOOR**

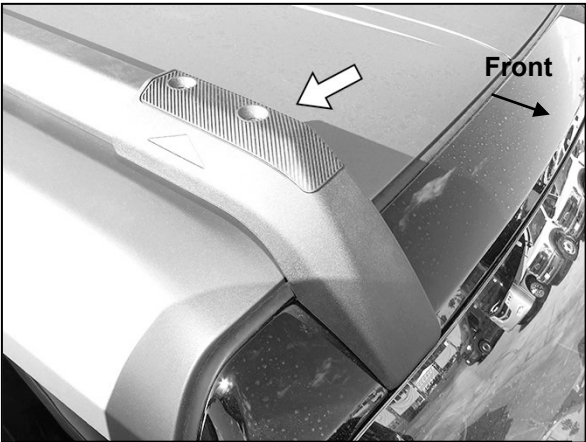

**(Fig 1) Models with factory roof rails,
remove cover to access mounting screws**

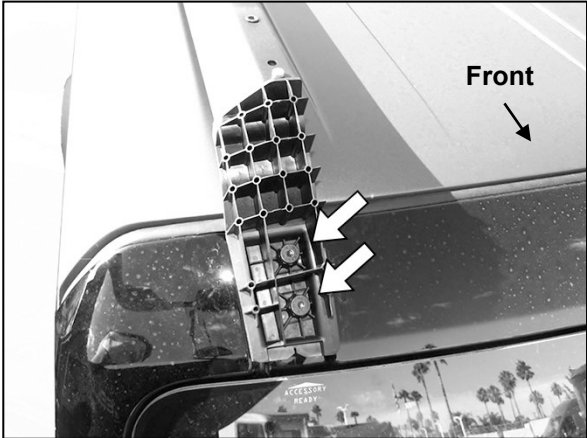

(Fig 2) Remove mounting hardware (arrows)



**(Fig 3) Models without factory roof rails,
remove cover and inner clip**

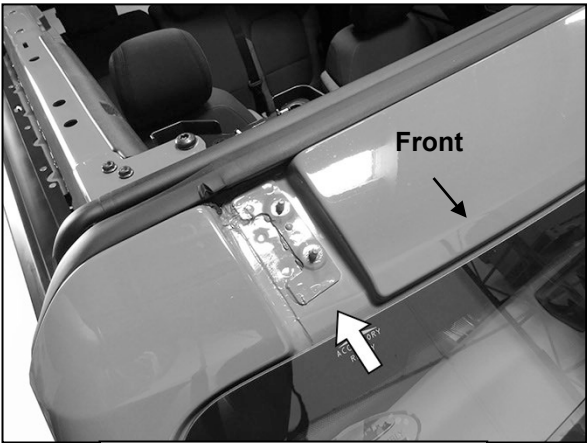

**(Fig 4) Passenger/right front
mounting location (arrow)**

**CR-1 ROOF RACK
2021 FORD BRONCO 4-DOOR**

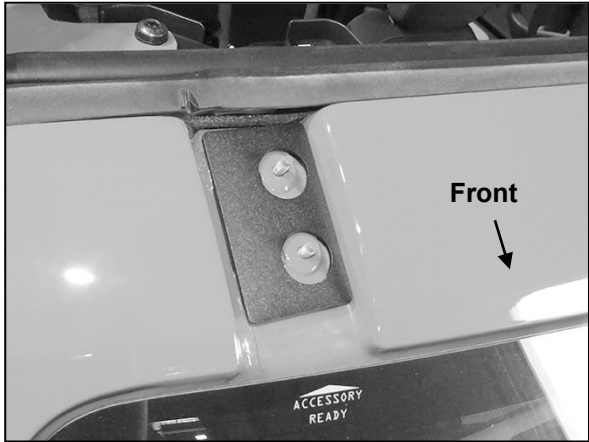

(Fig 5) Place Bracket Shim over threaded studs

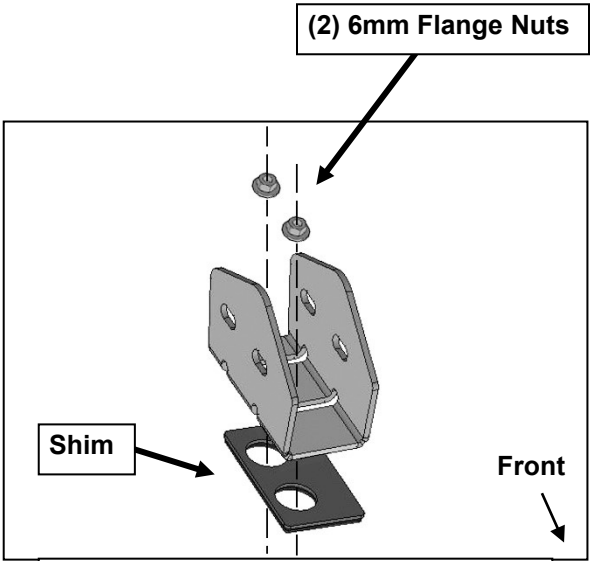

(Fig 6) Attach front crossbar Mounting Bracket to Shim and threaded studs. Driver/left side illustrated

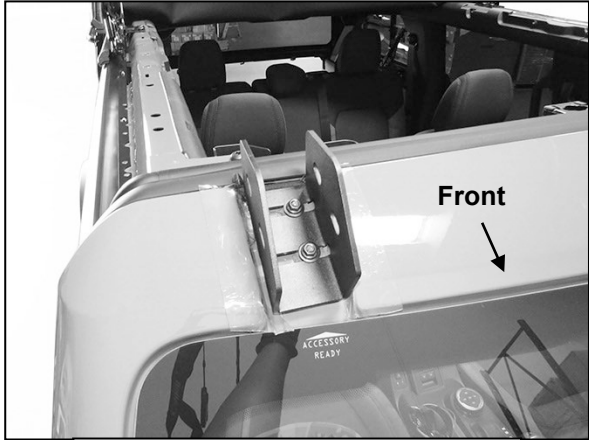

(Fig 7) Passenger/right side front Mounting Bracket installed

- 8mm x 30mm Button Head Bolt**
- (2) 8mm x 24mm Large Flat Washers**
- 8mm Nylon Lock Nut**

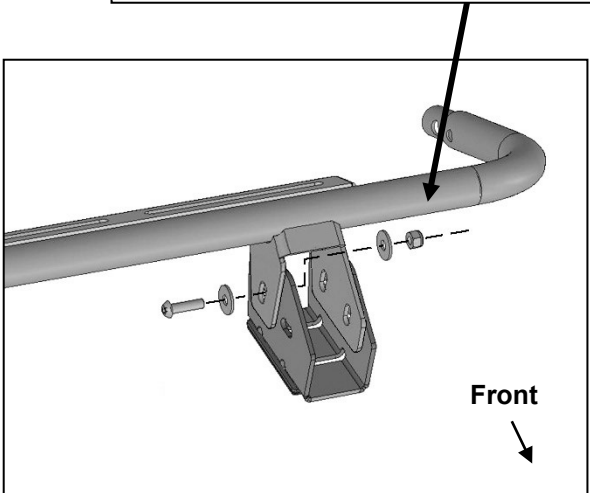

(Fig 8) Attach front Crossbar to inside of Mounting Bracket (driver/left side illustrated)

Driver/left Side Installation Pictured

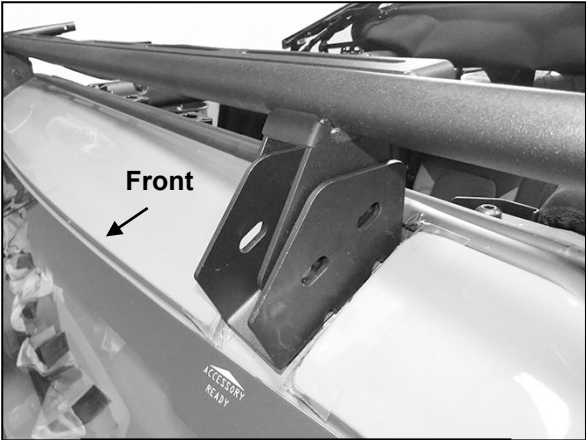

(Fig 9) Front Crossbar installed

- 8mm x 16mm Hex Bolt
8mm Lock Washer
8mm x 24mm Large Flat Washer
- 8mm Combo Bolt
8mm x 24mm Large Flat Washer
8mm Hex Nut

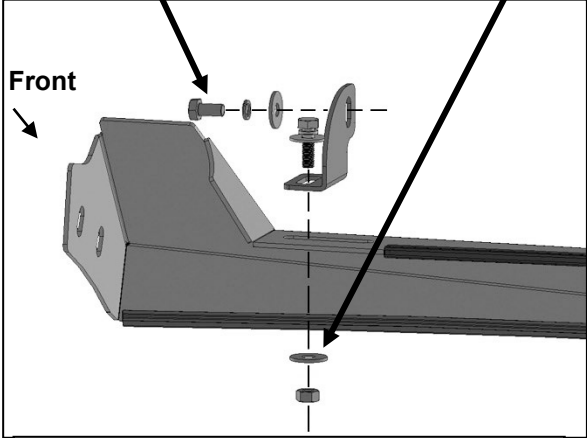

(Fig 10) Attach "L" Light Bracket to Wind Fairing (driver/left side illustrated)

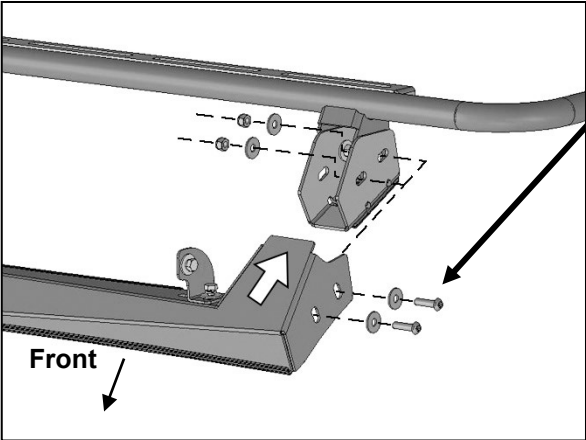

(Fig 11) Attach Wind Fairing to outside of Mounting Brackets

- (2) 8mm x 30mm Button Head Bolts
- (4) 8mm x 24mm Large Flat Washers
- (2) 8mm Nylon Lock Nuts

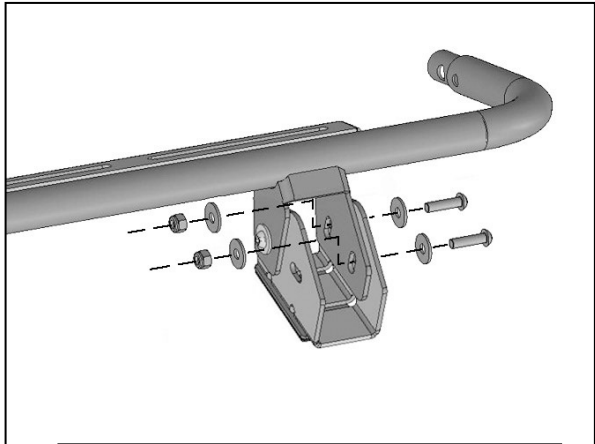

(Fig 12) Apply included Thread Lock Compound to Countersunk Bolts

Driver/left Side Installation Pictured

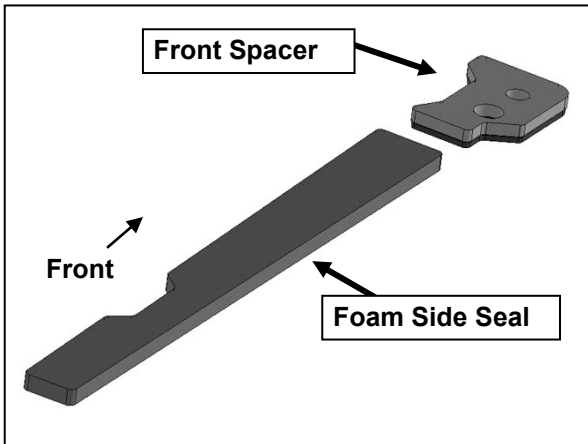

(Fig 13) Hard Top models only, remove hardware attaching roof. Temporarily remove or lift roof high enough to install Seals, Spacers and Brackets. Place Front Spacer over front threaded mounting hole (see Fig 14). Apply adhesive backed Foam Side Seal to top of body

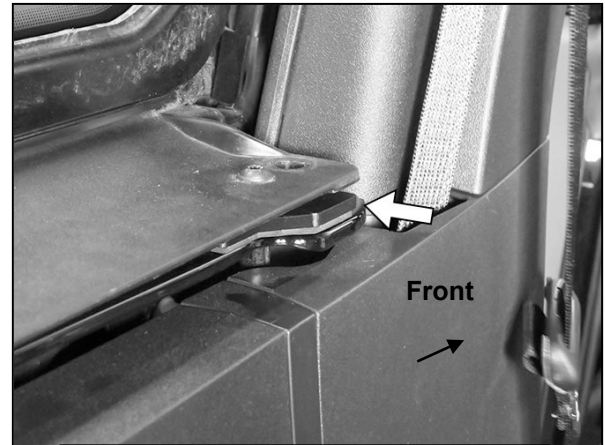

(Fig 14) Driver/left Front Spacer in place between top and body (arrow)

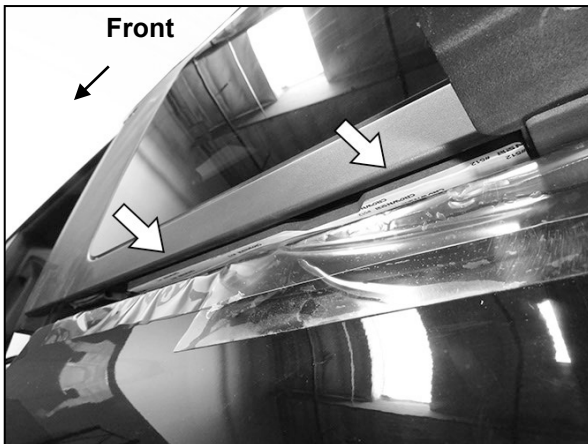

(Fig 15) Remove backing and apply adhesive backed Foam Side Seal to top of body, between top and body (arrows)



(Fig 16) Place the driver/left Mounting Bracket in place over threaded holes in body. Remove backing and apply adhesive backed Foam Rear Seal (see Fig 17) to top of body, between top and body

Driver/left Side Installation Pictured



(Fig 17) Apply adhesive backed Foam Rear Seal to top of body, between top and body (driver/left side pictured)

- (3) 8mm x 35mm Button Head TORX Bolts
- (3) 8mm Lock Washers
- (3) 8mm x 20mm STD Flat Washers

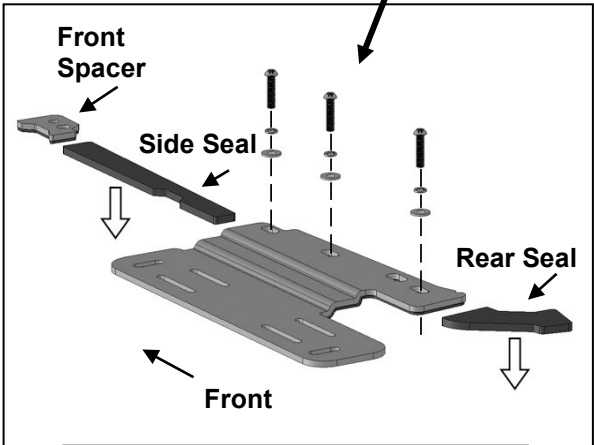

(Fig 18) Reinstall roof with Bracket between roof and body.

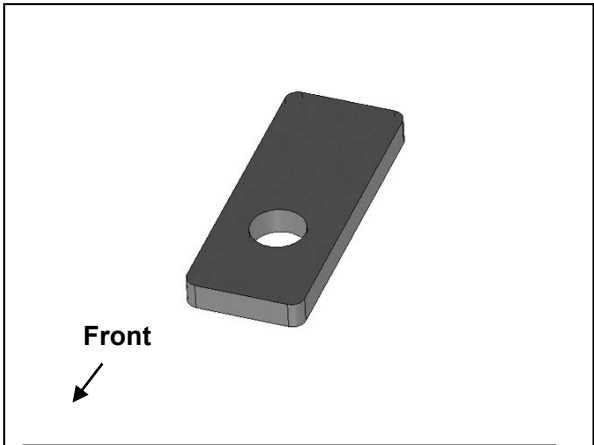

(Fig 19) Hard Top only Top Roof Spacer

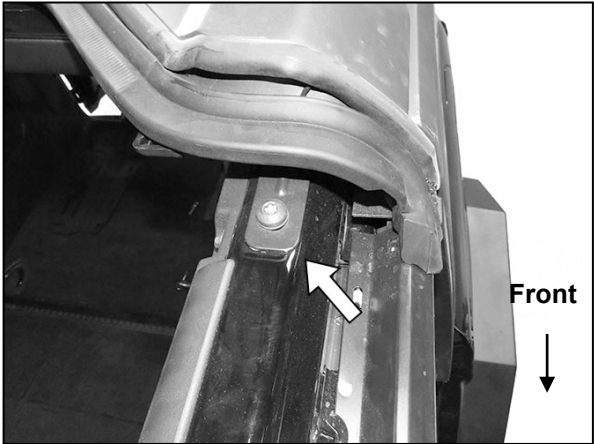

(Fig 20) Insert Top Roof Spacer between top bracket (arrow) and inner roll bar (driver/left side pictured)

Driver/left Side Installation Pictured

- (3) 8mm x 35mm Button Head TORX Bolts
- (3) 8mm Lock Washers
- (3) 8mm x 20mm STD Flat Washers

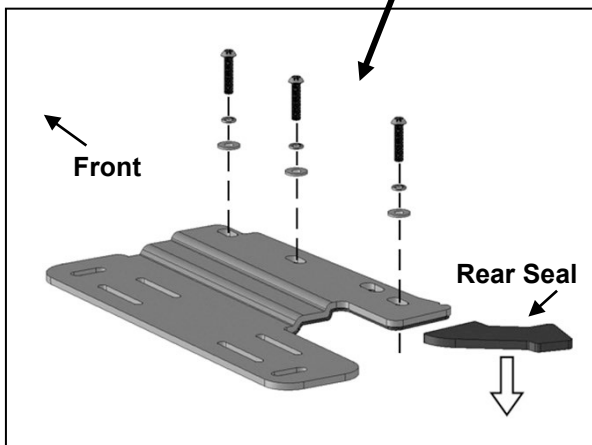

(Fig 21) Soft Top models only, remove side and rear windows. Release latches attaching rear or top frame. Lift top frame. Attach Roof Rack Mounting Brackets to threaded holes in top of body. Apply adhesive backed Foam Rear Seal to top of body, between top frame and body (driver/left side illustrated)

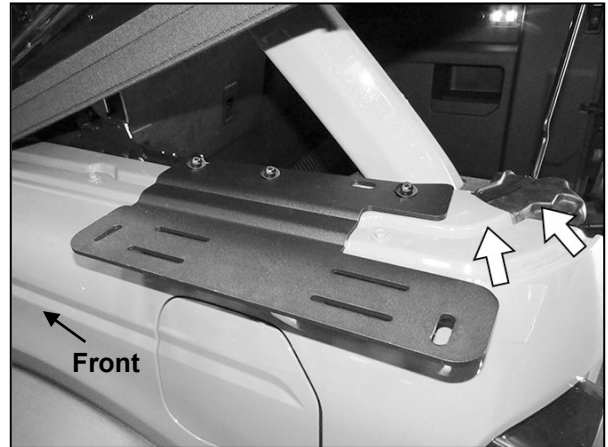

(Fig 22) Soft Top models only, Lift top frame. Attach Roof Rack Mounting Brackets to threaded holes in top of body. Apply adhesive backed Foam Rear Seal to top of body, between top frame and body (arrows)

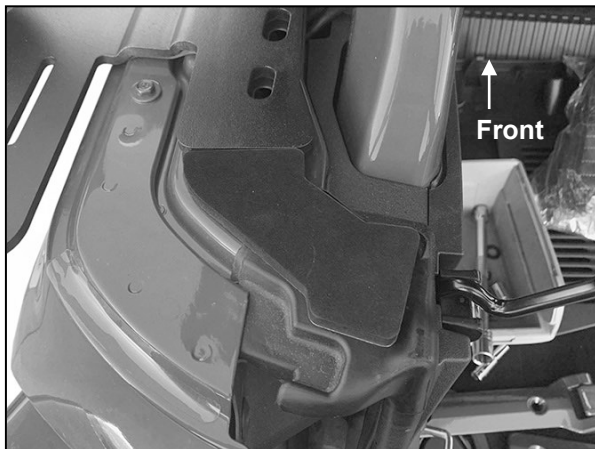

(Fig 23) Apply adhesive backed Foam Rear Seal to top of body, between top frame and body (driver/left side pictured)

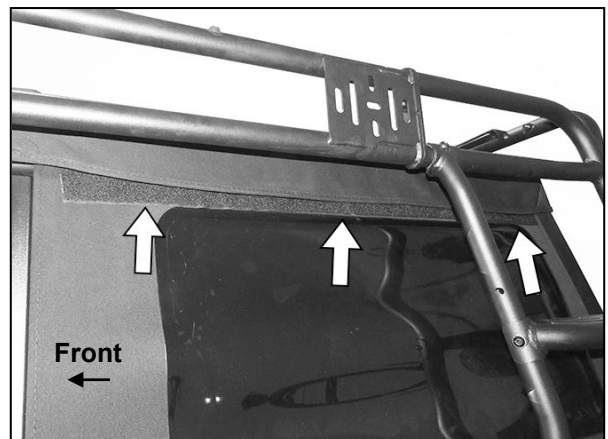

(Fig 24) Soft Top only, reinstall side and rear windows. Pull windows up tight and insert Hook and Loop Strip between top and side windows (arrows-driver/left side pictured after Roof Rack has been installed)

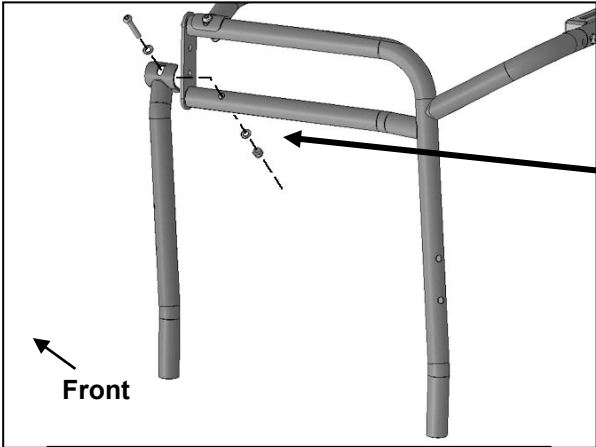

**8mm x 50mm Button Head Bolt
(2) 8mm x 16mm Small Flat Washers
8mm Nylon Lock Nut**

(Fig 25) Attach driver/left Support Leg to Corner Tube Assembly

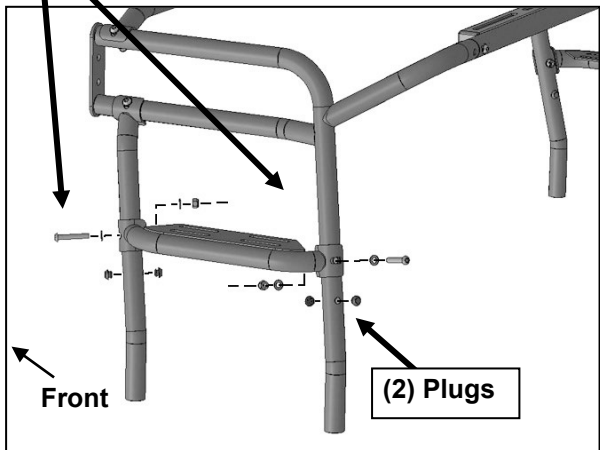

(Fig 26) Attach driver/left Ladder Step to either set of holes in Support Leg and Corner Tube Assembly

**(2) 8mm x 50mm Button Head Bolts
(4) 8mm x 16mm Small Flat Washers
(2) 8mm Nylon Lock Nuts**

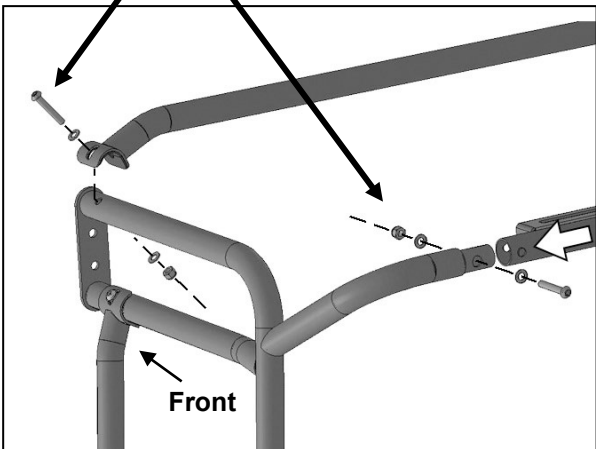

(Fig 27) Attach rear Cross Bar Tube and (1) Crossbar to Corner Assembly. Place rear assembly onto Mounting Brackets

**(2) 10mm x 30mm Hex Bolts
(2) 10mm Lock Washers
(2) 10mm Flat Washers**

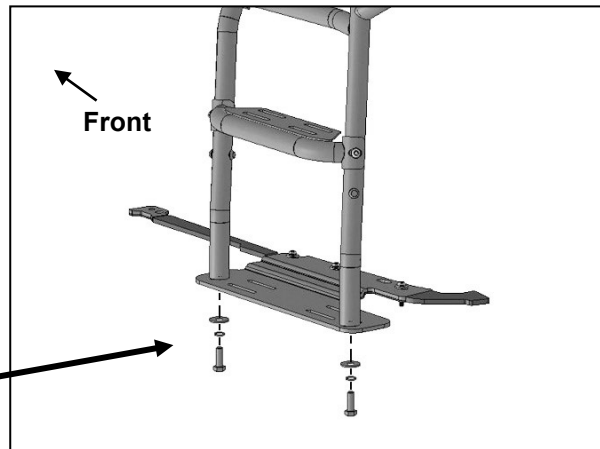

(Fig 28) Attach rear Rack Assembly to Mounting Brackets

**CR-1 ROOF RACK
2021 FORD BRONCO 4-DOOR**

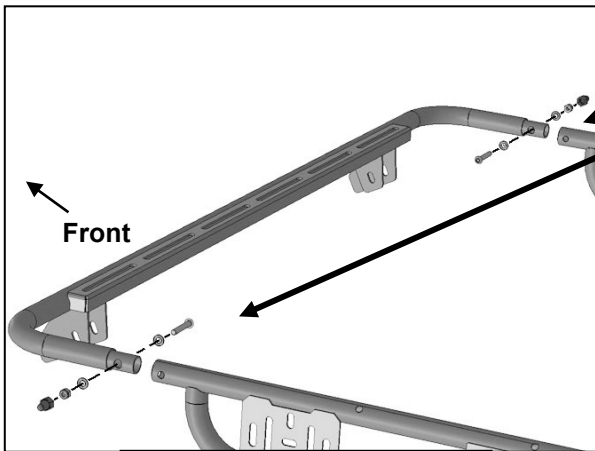

- (2) 8mm x 50mm Button Head Bolts
- (4) 8mm x 16mm Small Flat Washers
- (2) 8mm Nylon Lock Nuts
- (2) Plastic Caps

(Fig 29) Attach Side Rails to Front Cross Bar Tube

- (2) 8mm x 30mm Button Head Bolts
- (4) 8mm x 24mm Large Flat Washers
- (2) 8mm Nylon Lock Nuts

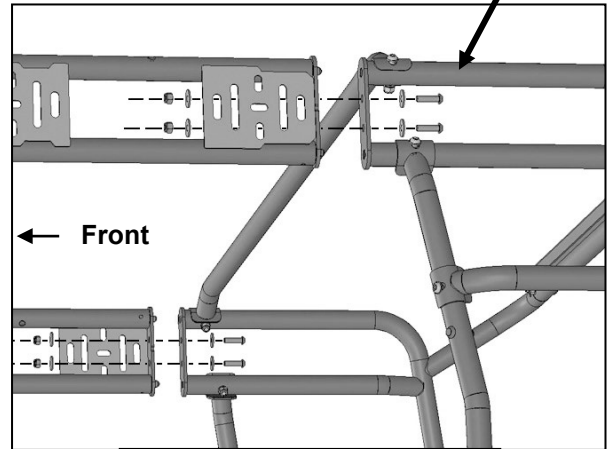

(Fig 30) Attach Side Rails to rear Rack Assembly

- (2) 8mm x 50mm Button Head Bolts
- (4) 8mm x 16mm Small Flat Washers
- (2) 8mm Nylon Lock Nuts
- or
- (2) Plugs

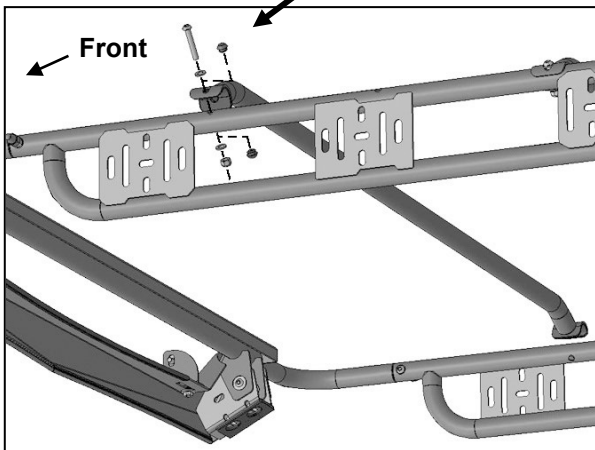

(Fig 31) Attach remaining Cross Bars to desired mounting holes in Side Rails. Use the included Plugs to seal off any unused mounting holes, (driver/left side illustrated from below)

- (3) 8mm Flange Nuts

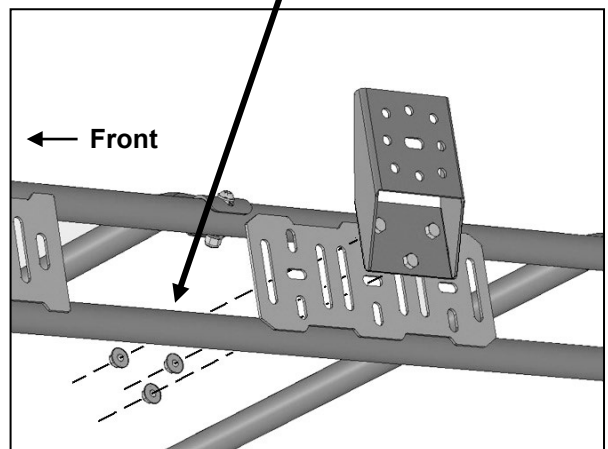

(Fig 32) Attach the Offset Accessory Mounts to the Side Rails as desired (driver/left side illustrated)