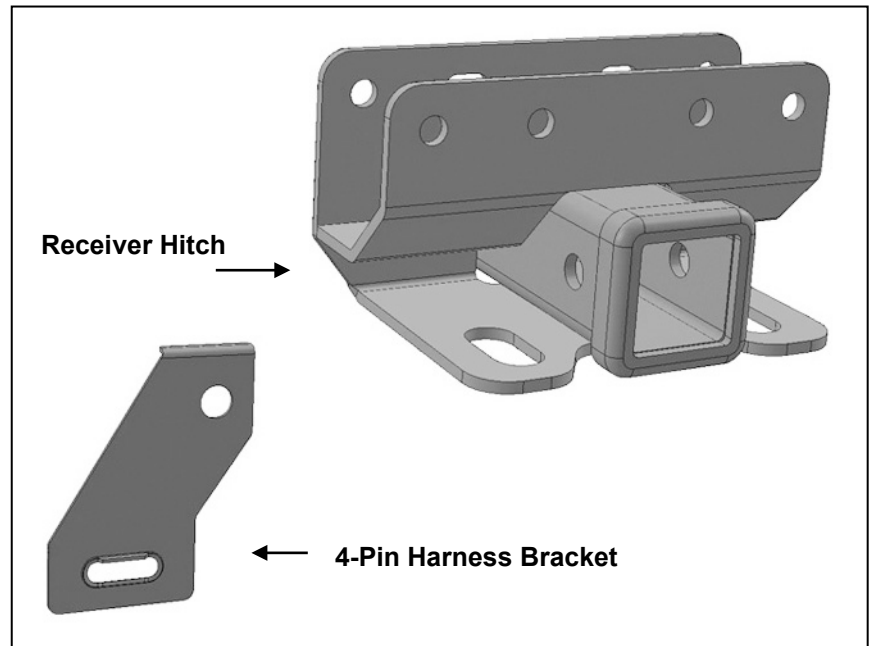

PARTS LIST:

1	Receiver Towing Hitch
1	Harness Bracket
4	12-1.75mm x 110mm Hex Bolts
8	12mm x 32mm x 3mm Flat Washers
4	12mm Nylon Lock Nuts

**PROCEDURE:**

REMOVE CONTENTS FROM BOX. VERIFY ALL PARTS ARE PRESENT. READ INSTRUCTIONS CAREFULLY BEFORE STARTING INSTALLATION.

1. Locate the mounting holes in the frame crossmember behind the rear bumper, **(Figure 1)**.
2. Carefully unwrap the Receiver Hitch. Line up the holes in the Hitch with the crossmember.
3. Attach the Hitch to the crossmember with the included (4) 12mm x 110mm Hex Bolts, (8) 12mm Flat Washers and (4) 12mm Nylon Lock Nuts, **(Figures 2 & 3)**. **NOTE:** Insert the Hex Bolts from the front of the crossmember through the back. Leave hardware loose at this time.
4. Select the 4-Pin Wire Harness Bracket, **(Figure 2)**. Remove the Flat Washer and Lock Nut from the driver/left outer end of the Receiver Hitch. Slide the Harness Bracket over the end of the Hex Bolt, **(Figures 2 & 4)**. Reuse the Flat Washer and Lock Nut to secure the Bracket to the Hitch.
5. Center and adjust the Receiver Hitch and fully tighten all hardware.
6. Attach the trailer harness to the Trailer Connection Tab, if installed, **(Figure 5)**.
7. Do periodic inspections of the installation to make sure that all hardware is secure and tight.

To protect your investment, Do not use any type of polish or wax that may contain abrasives that could damage the finish. Use mild soap to clean the Receiver Hitch.

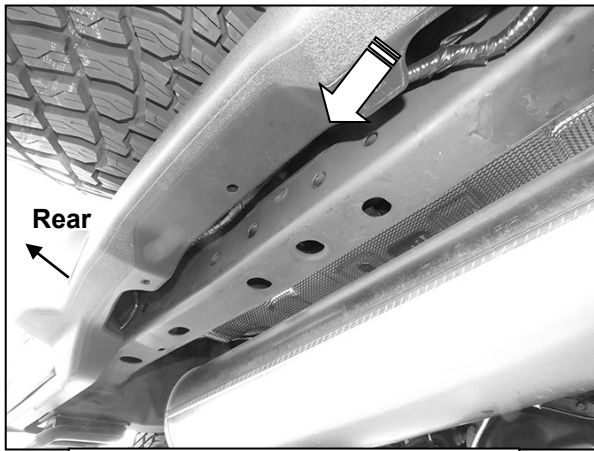

(Fig 1) Mounting location on rear crossmember (arrow)

- (4) 12mm x 110mm Hex Bolts
- (8) 12mm Flat Washers
- (4) 12mm Nylon Lock Nuts

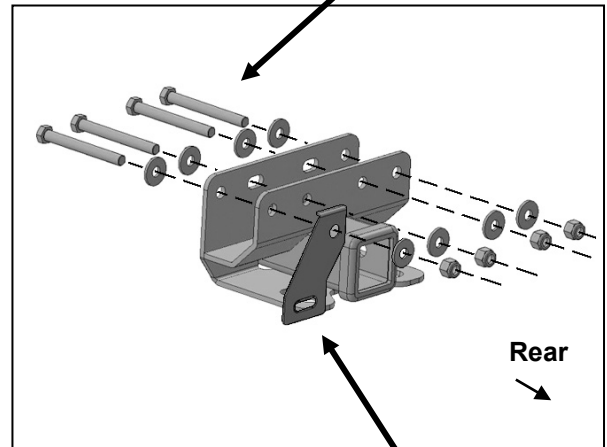

(Fig 2) Slide Hitch over crossmember.
Attach Harness Bracket to driver/left outer
Hex Bolt (arrow)

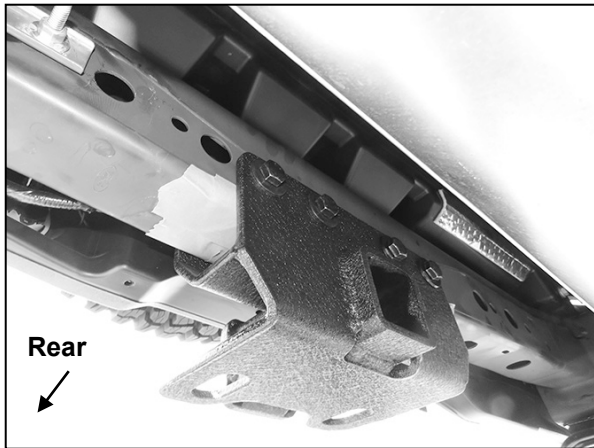

(Fig 3) Insert Hex Bolts from front facing
side of Hitch and crossmember

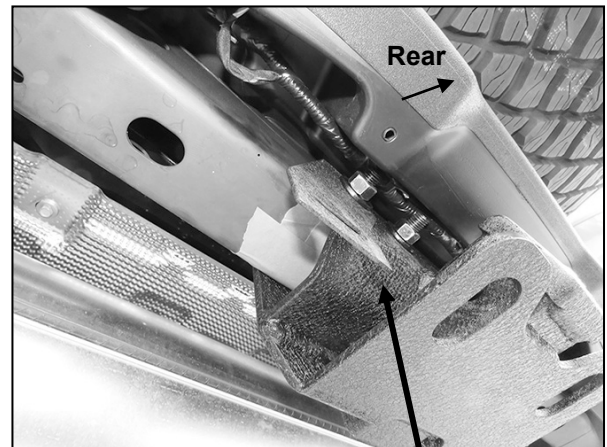

(Fig 4) Attach Harness Bracket to driver/left
outer Hex Bolt (arrow)



(Fig 5) Receiver Hitch and
Harness Bracket installed